

Photoelectric Sensor E3F3

Threaded Cylindrical Photoelectric Sensor with Built-in Amplifier for Use as an Optical Proximity Sensor

High Noise-immunity with Photo-IC Technology

- Up-to-date photo-IC to increase noise immunity.
- M18 DIN-sized cylindrical housing, ABS resin case.
- Compact and space-saving.
- Long sensing distance (30 cm) with sensitivity adjuster for diffuse type.
- Short-circuit and reverse connection protection.



<READ AND UNDERSTAND THIS CATALOG>

Please read and understand this catalog before purchasing the products. Please consult your OMRON representative if you have any questions or comments.

Ordering Information

Infrared light Red light

Sensing method	Appearance	Connection method	Sensing distance	Operating modes	Model	
					NPN output	PNP output
Through-beam		Pre-wired		Dark-ON	E3F3-T61	E3F3-T81
				Light-ON	E3F3-T11	E3F3-T31
Retroreflective		Pre-wired		Dark-ON	E3F3-R61	E3F3-R81
Diffuse reflective					Light-ON	E3F3-D11
			E3F3-D12	E3F3-D32		

Note: Light-ON retroreflective models and Dark-ON diffuse reflective models are also available.

■ Accessories (Order Separately)

Name	Model
Reflector	E39-R1, E39-R3
Reflector (tape type)	E39-RS1, E39-RS2, E39-RS3
Lens Cap	E39-F31
Mounting Bracket	Y92E-B18

Note: E39-R1 is included in E3F3-R61 and E3F3-R81.

Specifications

■ Ratings/Characteristics

Item	Sensing method	Through-beam	Retroreflective	Diffuse reflective	
	NPN output	E3F3-T61 E3F3-T11	E3F3-R61	E3F3-D11	E3F3-D12
	PNP output	E3F3-T81 E3F3-T31	E3F3-R81	E3F3-D31	E3F3-D32
Sensing distance	5 m		2 m (when using E39-R1)	100 mm	300 mm
Standard sensing object	Opaque object: 11 mm min.		Opaque object: 56 mm min.	100 × 100 mm white mat paper	100 × 100 mm white mat paper
Hysteresis	---			20% max. of sensing distance	
Light source (wavelength)	Infrared LED (860 nm)		Red LED (680 nm)	Infrared LED (860 nm)	
Power supply voltage	12 to 24 VDC±10%, ripple (p-p): 10% max.				
Current consumption	45 mA max. (light source and receiver)		25 mA max.		
Control output	Open collector transistor output, 100 mA max., residual voltage: 1 V max. at 100 mA				
Protective circuit	Output short-circuit protection, DC power supply reverse polarity protection				
Response time	2.5 ms max.				
Sensitivity adjustment	---				Single-turn adjuster
Ambient illumination	Incandescent lamp: 3,000 lx max., Sunlight: 10,000 lx max.				
Ambient temperature	Operating: -25 to 55 °C (with no icing or condensation) Storage: -30 to 70 °C (with no icing or condensation)				
Ambient humidity	Operating: 35% to 85% (with no condensation) Storage: 35% to 95% (with no condensation)				
Insulation resistance	20 MΩ min. (at 500 VDC) between current carry parts and case				
Dielectric strength	1,000 VAC at 50/60 Hz for 1 min between current carry parts and case				
Vibration resistance (destruction)	10 to 55 Hz, 1.5-mm double amplitude for 1 hour each in X, Y, and Z directions				
Shock resistance (destruction)	500 m/s ² for 3 times each in X, Y, and Z directions				
Degree of protection	IEC60529 IP66				
Connecting method	Pre-wired (standard length: 2 m)				
Indicators	Light source: Power indicator (orange) Receiver: Operation indicator (orange)		Operation indicator (orange)		
Weight (packed state)	170 g max.		85 g max.		
Material	Case	ABS			
	Lens	PMMA			
Accessories	Instruction sheet, screw nuts (2), E39-R1 reflector (E3F3-R only), Adjusting Driver (E3F3-D12/D32)				

Engineering Data

Parallel Operating Range (Typical)

Through-beam Models
E3F3-T61/T11/T81/T31

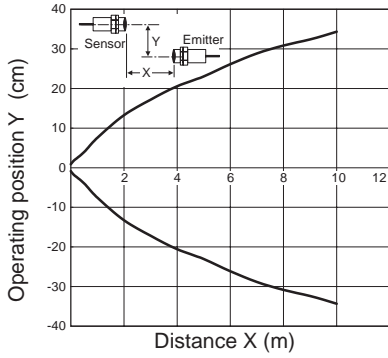

Retroreflective Models
E3F3-R61/R81+E39-R1

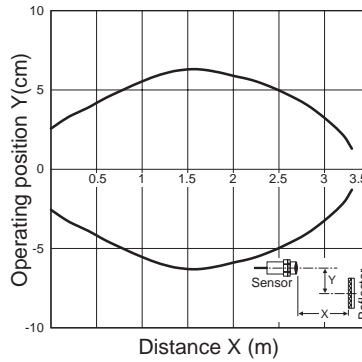

Operating Range (Typical)

Diffuse-reflective Models
E3F3-D11/D31

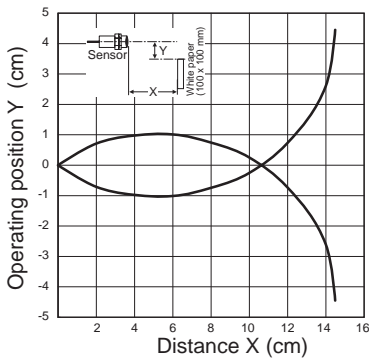

Diffuse-reflective Models
E3F3-D12/D32

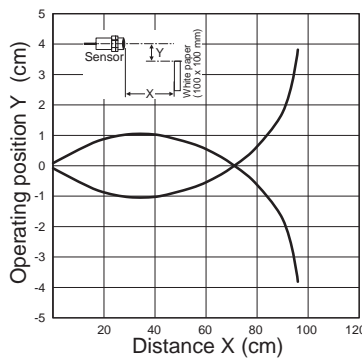

Excess Gain Ratio vs. Set Distance (Typical)

Through-beam Models
E3F3-T61/T11/T81/T31

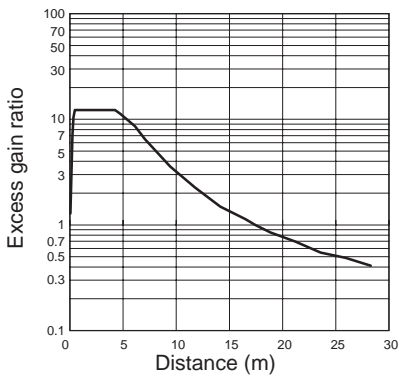

Retroreflective Models
E3F3-R61/R81+E39-R1

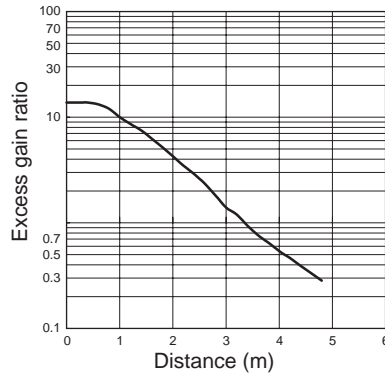

Diffuse-reflective Models
E3F3-D11/D31

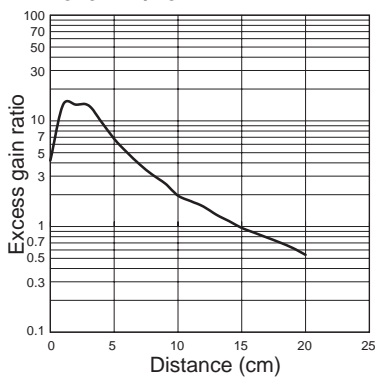

Diffuse-reflective Models
E3F3-D12/D32

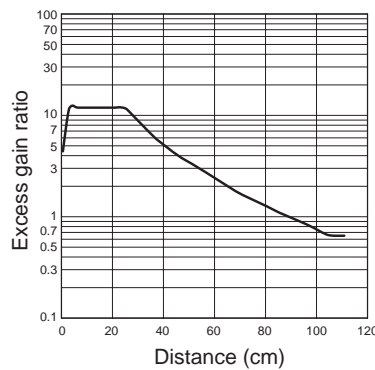

Sensing Distance vs. Object Size (Typical)

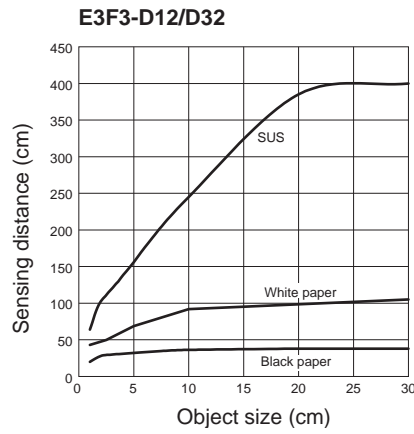
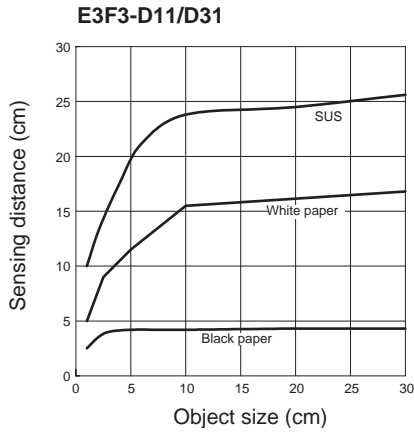

Operation

■ NPN Output

Model	Output transistor status	Timing chart	Output circuit
E3F3-T11 E3F3-D11 E3F3-D12	Light-ON	<p>Incident light: [ON] [OFF]</p> <p>Operation indicator (orange): ON [ON] OFF [OFF]</p> <p>Control output: ON [ON] OFF [OFF]</p> <p>Load (relay): Operate [ON] Release [OFF] (Between brown and black)</p>	
E3F3-T61 E3F3-R61	Dark-ON	<p>Incident light: [ON] [OFF]</p> <p>Operation indicator (orange): ON [ON] OFF [OFF]</p> <p>Control output: ON [ON] OFF [OFF]</p> <p>Load (relay): Operate [ON] Release [OFF] (Between brown and black)</p>	

■ PNP Output

Model	Output transistor status	Timing chart	Output circuit
E3F3-T31 E3F3-D31 E3F3-D32	Light-ON	<p>Incident light: [ON] [OFF]</p> <p>Operation indicator (orange): ON [ON] OFF [OFF]</p> <p>Control output: ON [ON] OFF [OFF]</p> <p>Load (relay): Operate [ON] Release [OFF] (Between blue and black)</p>	
E3F3-T81 E3F3-R81	Dark-ON	<p>Incident light: [ON] [OFF]</p> <p>Operation indicator (orange): ON [ON] OFF [OFF]</p> <p>Control output: ON [ON] OFF [OFF]</p> <p>Load (relay): Operate [ON] Release [OFF] (Between blue and black)</p>	

Dimensions

Note: All units are in millimeters unless otherwise indicated.

Sensors

E3F3-T61/T11/T81/T31
 E3F2-R61/R81
 E3F2-D11/D31

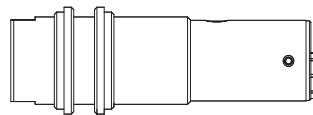
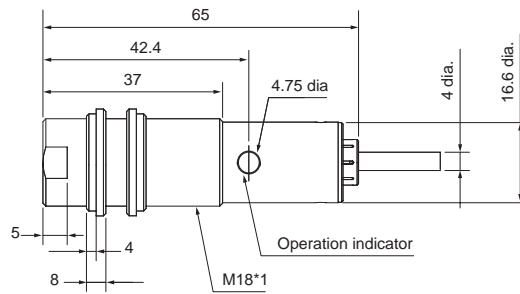
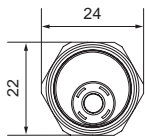
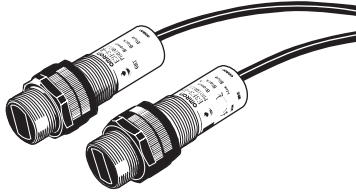

E3F3-T61/T11/T81/T31
 Emitter: Polyvinyl chloride-covered cord, 4 mm dia. (18/0.12)
 2-conductor (brown and blue) standard length: 2 m
 Receiver: Polyvinyl chloride-covered cord, 4 mm dia. (18/0.12)
 3-conductor (brown, blue and black) standard length: 2 m

E3F3-D12/D32

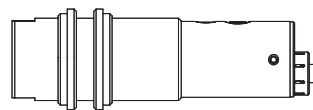
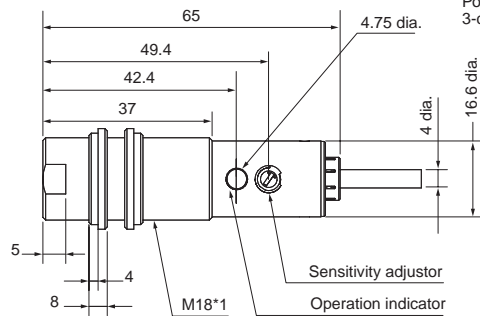
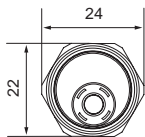

E3F2-R61/R81
E3F2-D11/D31
 Polyvinyl chloride-covered cord, 4 mm dia. (18/0.12)
 3-conductor (brown, blue, and black) standard length: 2 m

Polyvinyl chloride-covered cord, 4 mm dia. (18/0.12)
 3-conductor (brown, blue, and black) standard length: 2 m

Accessories (Order Separately)

E39-R1 Reflector

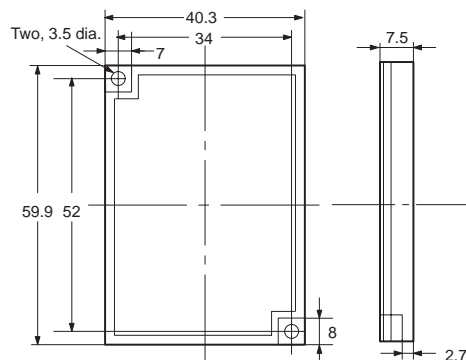
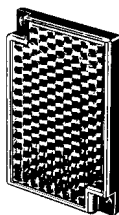

Precautions

If the input/output lines of the photoelectric sensor are placed in the same conduit or duct as power lines or high-voltage lines, the photoelectric sensor could be induced to malfunction, or even be damaged, by electrical noise. Separate the wiring, or use shielded lines as input/output lines to the photoelectric sensor.

Do not subject the photoelectric sensor to excessive shock when mounting, in keeping with IP66 standards.

When you use the photoelectric sensor in the vicinity of an inverter motor, be sure to connect the protective ground wire of the motor to ground. Failure to ground the motor may result in malfunction of the sensor.

Mounting

Do not exceed a torque of 20 kgf·cm (2.0 N·m) when tightening mounting nuts.

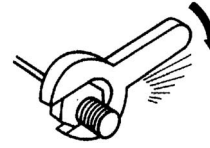

WARNING

The E3F3 Photoelectric sensor is not a safety component for ensuring the safety of people as defined by EC Directives (91/386 EEC) and covered by separate European standards or by any other regulations or standards.

Warranties and Limitations of Liability

■ WARRANTY

OMRON's exclusive warranty is that the products are free from defects in materials and workmanship for a period of one year (or other period if specified) from date of sale by OMRON.

OMRON MAKES NO WARRANTY OR REPRESENTATION, EXPRESS OR IMPLIED, REGARDING NON-INFRINGEMENT, MERCHANTABILITY, OR FITNESS FOR PARTICULAR PURPOSE OF THE PRODUCTS. ANY BUYER OR USER ACKNOWLEDGES THAT THE BUYER OR USER ALONE HAS DETERMINED THAT THE PRODUCTS WILL SUITABLY MEET THE REQUIREMENTS OF THEIR INTENDED USE. OMRON DISCLAIMS ALL OTHER WARRANTIES, EXPRESS OR IMPLIED.

■ LIMITATIONS OF LIABILITY

OMRON SHALL NOT BE RESPONSIBLE FOR SPECIAL, INDIRECT, OR CONSEQUENTIAL DAMAGES, LOSS OF PROFITS OR COMMERCIAL LOSS IN ANY WAY CONNECTED WITH THE PRODUCTS, WHETHER SUCH CLAIM IS BASED ON CONTRACT, WARRANTY, NEGLIGENCE, OR STRICT LIABILITY.

In no event shall responsibility of OMRON for any act exceed the individual price of the product on which liability is asserted.

IN NO EVENT SHALL OMRON BE RESPONSIBLE FOR WARRANTY, REPAIR, OR OTHER CLAIMS REGARDING THE PRODUCTS UNLESS OMRON'S ANALYSIS CONFIRMS THAT THE PRODUCTS WERE PROPERLY HANDLED, STORED, INSTALLED, AND MAINTAINED AND NOT SUBJECT TO CONTAMINATION, ABUSE, MISUSE, OR INAPPROPRIATE MODIFICATION OR REPAIR.

Application Considerations

■ SUITABILITY FOR USE

OMRON shall not be responsible for conformity with any standards, codes, or regulations that apply to the combination of products in the customer's application or use of the products.

Take all necessary steps to determine the suitability of the product for the systems, machines, and equipment with which it will be used.

Know and observe all prohibitions of use applicable to this product.

NEVER USE THE PRODUCTS FOR AN APPLICATION INVOLVING SERIOUS RISK TO LIFE OR PROPERTY WITHOUT ENSURING THAT THE SYSTEM AS A WHOLE HAS BEEN DESIGNED TO ADDRESS THE RISKS, AND THAT THE OMRON PRODUCTS IS PROPERLY RATED AND INSTALLED FOR THE INTENDED USE WITHIN THE OVERALL EQUIPMENT OR SYSTEM.

Disclaimers

■ CHANGE IN SPECIFICATIONS

Product specifications and accessories may be changed at any time based on improvements and other reasons. Consult with your OMRON representative at any time to confirm actual specifications of purchased product.

■ DIMENSIONS AND WEIGHTS

Dimensions and weights are nominal and are not to be used for manufacturing purposes, even when tolerances are shown.

ALL DIMENSIONS SHOWN ARE IN MILLIMETERS.

To convert millimeters into inches, multiply by 0.03937. To convert grams into ounces, multiply by 0.03527.

Cat. No. E333-E1-01

In the interest of product improvement, specifications are subject to change without notice.

OMRON Corporation

Industrial Automation Company

Industrial Sensors Division

Sensing Devices and Components Division H.Q.

3-2, Narutani, Nakayama-cho, Ayabe-shi,

Kyoto, 623-0105 Japan

Tel: (81)773-43-4078/Fax: (81)773-43-4030

Printed in Japan
0403-1M (0403) (A)