

Compact Simplified Inverters EasySpeed 3G3JE Series

A compact Inverter with a simplified design and easy installation.

- The same compact size (width: 55 mm) for all models from 0.1 to 0.4 kW
- Simplified installation using DIN Track. No mounting brackets required.
- Mount side-by-side (ambient temperature: 45°C max.).
- Easy-to-wire main circuits.
- Models with CompoWay/F communications also available.
- Control mode easily set by simply selecting an application.
- Built-in inrush current suppression circuit.
- Accumulated operating time function for preventive maintenance of equipment
- Handles temperature controller voltage output signals.
- Conforms to international standards (CE (TÜV certified)).



NEW

Model Number Structure

■ Model Number Legend

3G3JE-A2□□□□-□□□□
1 2 3 4 5

1. Degree of Protection

A: Panel-mounting (IP10 or higher)/Closed wall-mounting

2. Voltage Class

2: Three-phase 200 V AC

3. Maximum Applicable Motor Capacity

001: 0.1 kW

002: 0.2 kW

004: 0.4 kW

4. Braking Resistor Control

Blank: No braking resistance control

B: Braking resistance control

5. Communications

Blank: No communications function

FLK: CompoWay/F

Ordering Information

■ Inverters

Model number		3G3JE		
Maximum motor capacity		0.1 kW	0.2 kW	0.4 kW
No braking resistance control	Standard models	3G3JE-A2001	3G3JE-A2002	3G3JE-A2004
	Communications models	3G3JE-A2001-FLK	---	---
Braking resistance control	Standard models	---	3G3JE-A2002B	3G3JE-A2004B
	Communications models	---	3G3JE-A2002B-FLK	3G3JE-A2004B-FLK

■ Options (Order Separately)

Product name	Specifications	Model number	Description
Fan Unit	Special for the 3G3JE	3G3JE-PFAN2004	Replacement for the existing cooling fan in the Inverter. Replace the cooling fan if it has reached the end of its service life or if a warning of cooling fan failure (E07) is indicated.
AC Reactor (0.1/0.2 kW)	For 200 V	3G3IV-PUZBAB2A7.0MH	Connect an AC Reactor to the Inverter to suppress harmonic current generated from the Inverter, or if the power supply capacity is much greater than the Inverter capacity. The AC Reactor also improves the power factor of the Inverter.
AC Reactor (0.4 kW)	For 200 V	3G3IV-PUZBAB2.5A4.2MH	
EMC-compliant Input Noise Filter (Rasmi)	For three-phase 200 V AC	3G3JV-PRS2010J	A noise filter on the input side meeting EC Directive EMC requirements.
Simple Input Noise Filter	For three-phase 200 V	3G3EV-PLNFD2103DY	Connect this Filter to the power input side to suppress noise entering the Inverter from the power line and reduce noise leaking from the Inverter into the power line.
Output Noise Filter (Token)	For 200 V	3G3IV-PLF310KA	Connect this Filter to the motor output side of the Inverter to suppress the noise generated by the Inverter from being transmitted to the output side.
Braking Resistor	For 200 V	3G3IV-PERF150WJ201	Uses a resistor to absorb the motor's regenerative energy to reduce deceleration time. (Usage rate: 3% ED)
Braking Resistor Unit	For 200 V	3G3IV-PLKEB20P7	Uses a resistor to absorb the motor's regenerative energy to reduce deceleration time. (Usage rate: 10% ED)

Specifications

■ Ratings

Item		Three-phase 200-V AC models (3G3JE)	A2001	A2002	A2004
Power supply	Rated voltage and power supply	Three-phase 200 to 230 V AC at 50/60 Hz			
	Allowable voltage fluctuation	-15 to 10%			
	Allowable frequency fluctuation	±5%			
	Input power supply capacity (kVA) (See note 1.)	0.4	0.7	1.2	
Heat radiation (W) (See note 2.)		6.8	14.8	21.9	
Approximate weight (kg)		0.3	0.4	0.4	
Cooling method		Self cooling		Forced cooling	
Maximum motor capacity (kW)		0.1	0.2	0.4	
Output specifications	Rated output capacity (kVA)	0.3	0.5	1.0	
	Rated output current (A)	0.8	1.4	2.5	
	Rated output voltage (V)	Three-phase 200 to 230 V AC			
	Maximum output frequency	120 Hz			
Short-circuit current rating for power output (motor output) (A)		36	54		
Short-circuit designation for auxiliary circuit (braking resistor connection)		---		No short-circuit protection	
Control characteristics	Power supply harmonics countermeasures	AC reactor			
	Control method	Sine wave PWM (V/f control)			
	Carrier frequency	4 kHz/7 kHz (switched according to setting)			
	Frequency control range	0.0 to 120 Hz			
	Frequency precision (temperature characteristics)	±0.3% of frequency reference (-10 to 50°C)			
	Frequency setting resolution	Digital commands: 0.1 Hz (less than 100 Hz) 1 Hz (100 Hz or greater) Time-proportional pulse input: ±0.5% of frequency reference			
	Overload capacity	150% of rated output current for 1 min			
	External frequency set signal	Time-proportional pulse input			
	Acceleration/deceleration times	0.1 to 999 s (independent acceleration and deceleration time settings)			
	Braking torque	Approx. 20% (with no Braking Resistor connected) Approx. 100% (with Braking Resistor connected)			
	Voltage/frequency characteristics	Constant torque characteristics or gradually decreasing torque characteristics (with automatic torque boost)			
	Protective functions	Motor protection	Protection by electronic thermal		
Instantaneous overcurrent protection		Stops at approx. 250% of rated output current.			
Overcurrent protection		Stops in 1 min at approximately 150% of rated output current.			
Overvoltage protection		Stops when main-circuit DC voltage is approximately 410 V.			
Undervoltage protection		Stops when main-circuit DC voltage is approximately 200 V.			
Momentary power interruption restart selection		Select from not restarting (stops for interruption of 15 ms or longer), continuing operation if power is restored within approx. 0.5 s, or continuing operation regardless of length of interruption			
Radiation fin overheating		Temperature is detected by a thermistor.			
Grounding protection		Protected by overcurrent protection.			
Charge indicator	Lit until the main circuit DC voltage drops to 60 V or less.				
Environment	Location	Inside a control panel (with no corrosive gas, dust, etc.)			
	Ambient operating temperature	-10 to 50°C			
	Ambient operating humidity	5% to 85% (with no condensation)			
	Shipping and storage temperature	-20 to 60°C			
	Shipping and storage humidity	5% to 85% (with no condensation)			
	Altitude	1,000 m max.			
	Insulation resistance	5 MΩ min.			
Vibration resistance	9.8 m/s ² max.				
Degree of protection		IP20			

Note: 1. The power supply capacity is the capacity for the Inverter's rated output. It will vary depending on the impedance at the input power supply. (The input power supply's power factor fluctuates, so it can be improved by inserting an AC reactor.) There will also be variations in the ratio between the rated current of the motor that is used and the rated output current of the Inverter.
 2. The heat radiation is the electric power consumed in the Inverter at the Inverter's rated output. (Calculated as the input power minus the output power during rated operation.)

■ Certified Standards

Safety standards	EN 61800-5-1 (Pollution Level 2/Overvoltage Category II)
EMC Directive	EN61800-3

Dimensions

Note: All units are in millimeters unless otherwise indicated.

■ Inverter

3G3JE-A2001/-A2002/-A2004: Three-phase 200-V AC Input

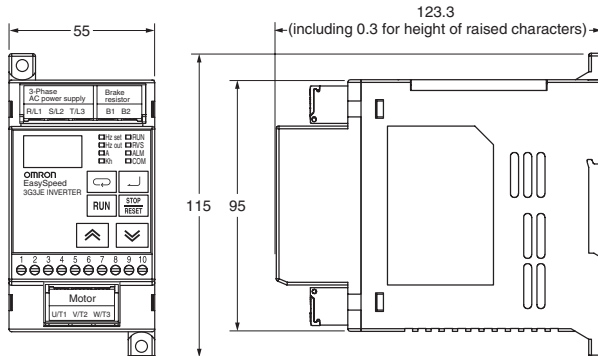
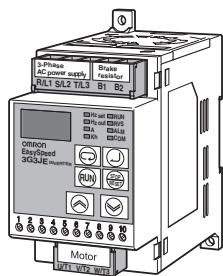

Panel Mounting Dimensions

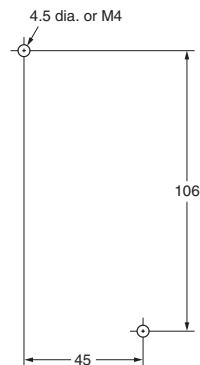

Note: All models are the same size.

Nomenclature and Functions

Indicators

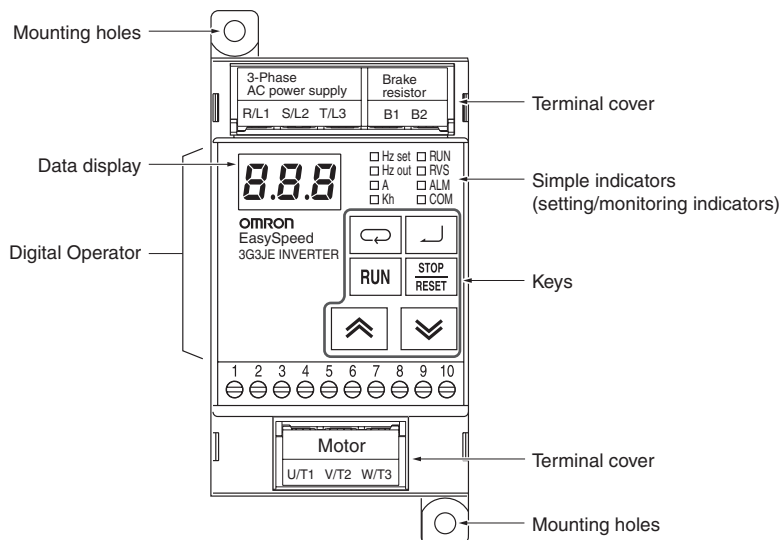

Digital Operator Part Names

Name	Function
	Data display Displays relevant data items, such as frequency reference, output frequency, output current, parameters, parameter set values, and accumulated operating time.
<input type="checkbox"/> Hz set	Frequency reference The Hz set indicator is lit when the frequency reference is displayed on the data display.
<input type="checkbox"/> Hz out	Output frequency The Hz out indicator is lit when the output reference is displayed on the data display.
<input type="checkbox"/> A	Output current The A indicator is lit when the output current is displayed on the data display.
<input type="checkbox"/> Kh	Accumulated operating time The Kh indicator is lit when the accumulated operating time is displayed on the data display.
<input type="checkbox"/> RUN	RUN The RUN indicator is lit while the Inverter is operating.
<input type="checkbox"/> RVS	Reverse operation The RVS indicator is lit while the Inverter is operating in reverse.
<input type="checkbox"/> ALM	Alarm The ALM indicator is lit when a fault is detected and a protective function has been triggered. (The error contents can be monitored in RUN Mode.)
<input type="checkbox"/> COM	Communicating The COM indicator is lit while communications are in progress (sending or receiving). (Communications models only.)
	Mode Key Switches the simple indicators (setting/monitoring indicators) in RUN Mode. When this key is pressed for one second or longer, the mode changes from the RUN Mode to the Initial Settings Mode.
	Enter Key Enters set values, display items, etc. When this key is pressed for one second or longer, the mode changes from the RUN Mode to the Adjustment Mode.
	RUN Key Starts the Inverter. (This applies only when the operation using the Digital Operator has been selected.)
	STOP/RESET Key Stops the Inverter. Also, clears error when an error has been detected and a protection function has been triggered. (This applies only when the operation using the Digital Operator has been selected.)
	Increment Key These keys increment or decrement the displayed set value. They also change parameters in the Adjustment Mode or Initial Settings Mode.

Terminal Block

Locations of Terminals

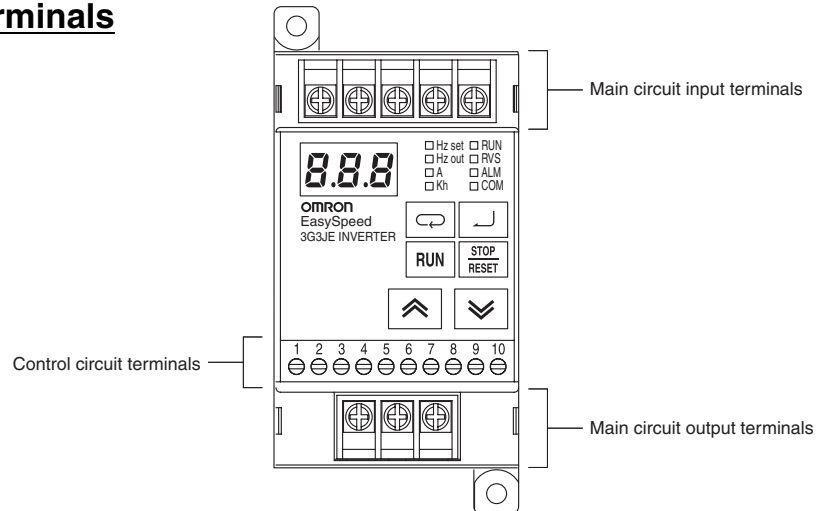

Main Circuit Terminals

Arrangement of Input Terminals

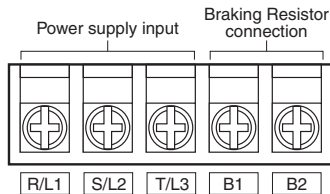

Arrangement of Output Terminals

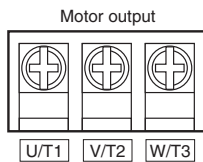

Control Circuit Terminals

Arrangement of Terminals

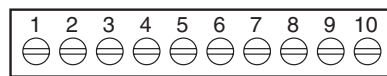

Descriptions of Terminals

Symbol	Name	Description
R/L1	Power supply inputs	Inputs for connecting three-phase 200-to-230-V AC power supply.
S/L2		
T/L3		
U/T1	Motor outputs	Three-phase power supply outputs for driving the motor.
V/T2		
W/T3		
B1	Between B1 and B2: Braking Resistor connection terminals	Connect between B1 and B2 to connect a Braking Resistor or a Braking Resistor Unit. (3G3JE-A2□□B models with braking resistor control only)
B2		

Descriptions of Terminals

Terminal	Standard models	Communications models
1	24 VDC	RS-485 (+)
2	SS0	RS-485 (-)
3	SS1	24 VDC
4	STF	STF
5	STR	STR
6	SC	SC
7	ALM (+)	ALM (+)
8	ALM (-)	ALM (-)
9	STA (+)	STA (+)
10	STA (-)	STA (-)

Standard Models

	Symbol	Name	Function	Specifications
Input	24 VDC	Internal 24-V power supply	The 24-V DC power supply input for Inverter control circuits. Do not use this power supply for any other purpose.	Photocoupler (24 V DC, 5 mA max.)
	SS0	Multi-step speed reference selection 0	SS0 and SS1 combine to select the multi-step speed reference.	
	SS1	Multi-step speed reference selection 1		
	STF	Forward/stop command	Forward operation command	
	STR	Reverse/stop command	Reverse operation command	
	SC	External power supply common	Common terminal for when internal 24-V power supply is not used.	
	Output	ALM (+)	Alarm output	
ALM (-)		Alarm output common	Common for ALM	
STA (+)		Multi-function output	Output when the selected operating status is reached.	
STA (-)		Multi-function output common	Common for STA	

Connections

Standard Connection Diagrams

Standard Models

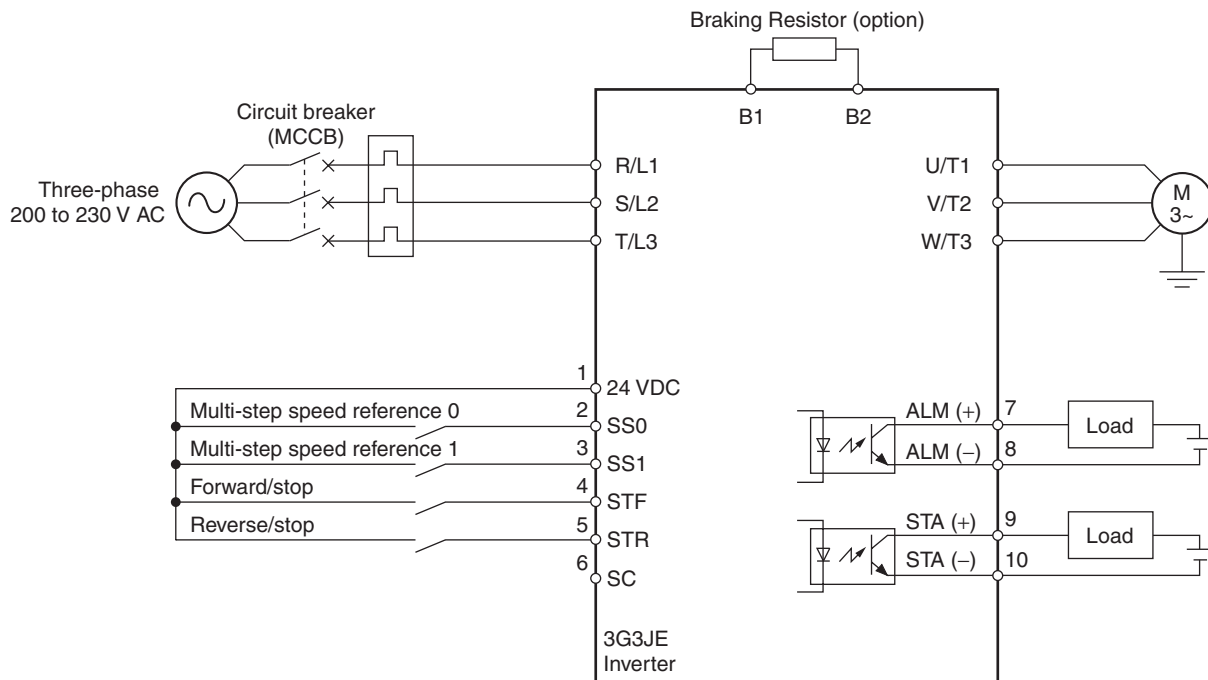

Communications Models

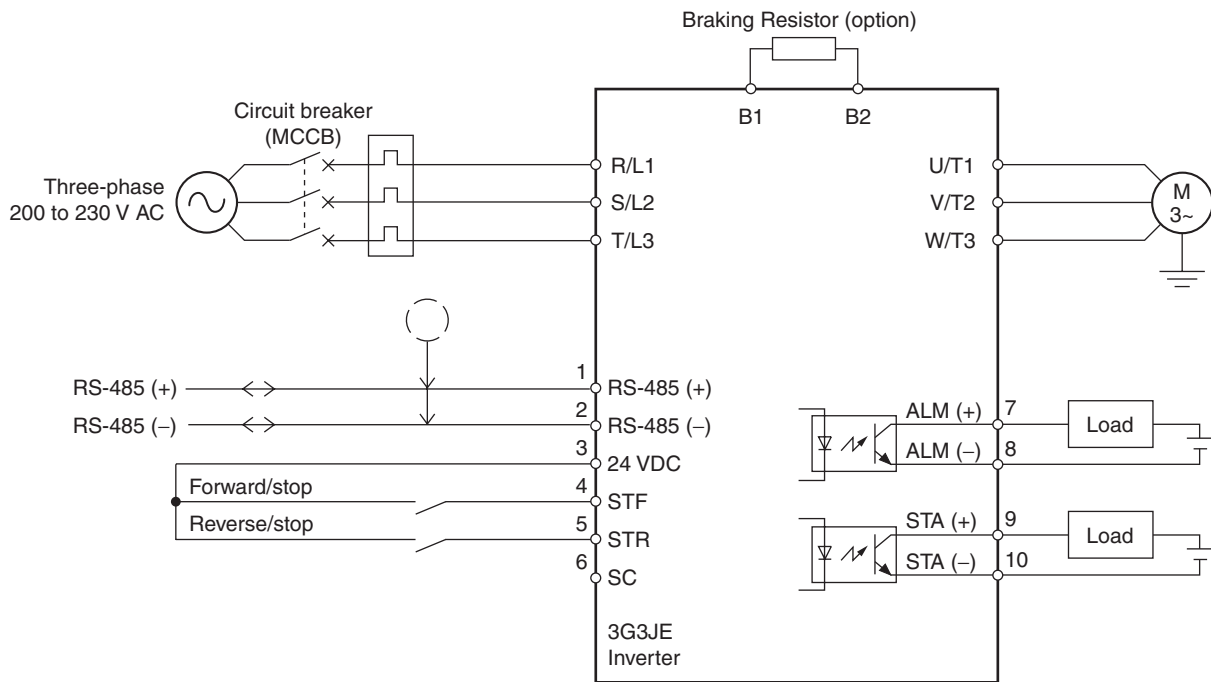

Note: The Braking Resistor (option) can be connected only to models with braking resistor control.

Operations and Settings

■ List of Parameters

RUN Mode

Name	Simple indicator	Data display (displayed contents)	Setting range	Default setting	Unit
Frequency reference	<input type="checkbox"/> Hz set	The frequency reference is displayed.	0.0 to 120	10.0	Hz
Output frequency	<input type="checkbox"/> Hz out	The output frequency is displayed.	---	---	Hz
Output current	<input type="checkbox"/> A	The output current is displayed.	---	---	A
Accumulated operating time	<input type="checkbox"/> Kh	The accumulated operating time is displayed.	---	---	Kh
Forward/reverse operation selection	<input type="checkbox"/> RVS (Lit for reverse operation command.)	The selected direction of rotation is displayed.	FWD (Fwd) REV (Rev)	FWD	None

- Note:**
1. The setting range of the frequency reference depends on the settings of the frequency reference upper limit (P07) and the frequency reference lower limit (P08).
 2. Even if the reverse operation command is set, the setting will return to the forward operation command when the power is cycled or Initial Settings Mode is entered.

Adjustment Mode

Name	Data display	Description	Setting range	Default setting	Unit
Frequency reference 1	SP1	Used to set internal frequency references. (Enabled when "MSP" is selected for the frequency reference selection (P11).)	0.0 to 120	10.0	Hz
Frequency reference 2	SP2			0.0	
Frequency reference 3	SP3			0.0	
Frequency reference 4	SP4			0.0	
Acceleration time	ACC	The acceleration time is the time required to accelerate from 0% to 100% of the maximum output frequency.	0.1 to 999	10.0	s
Deceleration time	DEC	The deceleration time is the time required to decelerate from 100% to 0% of the maximum output frequency.	0.1 to 999	10.0	s
Application selection	APP	Sets the V/f pattern as the basic characteristic according to the application. CNV: Conveyor applications FAN: Fan or pump applications	CNV (CNV) FAN (FAN)	CNV	None

- Note:**
1. Set values for SP1 to SP4, ACC, and DEC are changed in increments of 0.1 up to 99.9. From 100 and up they are changed in increments of 1.0.
 2. The time required to reach the set frequency from 0 Hz, or to reach 0 Hz from the set frequency, is as follows:
Acceleration (deceleration) time = Acceleration (deceleration) time value × Frequency reference value ÷ Maximum output frequency set value

Initial Settings Mode

Display	Name	Description	Setting range (See note 1.)	Default setting	Unit
P01	Rated motor current	Used to set the motor's rated current as the standard current for motor overload (E03) detection. (Motor overload protection will be disabled if 0.0 A is set.) The normal rated current for a motor with the maximum capacity supported by the Inverter is set as the default.	0.0 to 2.5	0.1 kW: 0.6 0.2 kW: 1.0 0.4 kW: 2.0	A
P02	Accumulated operating time standard	Used to set the alarm output time for the accumulated operating time alarm (E09).	0.0 to 99.9	20.0	Kh
P03	DC injection braking frequency	Used to set functions for applying DC current to an inductive motor to brake the motor. When stopping, DC braking operates at the DC braking standard frequency and below.	0.0 to 5.0	3.0	Hz
P04	Startup DC injection braking time		0.0 to 10.0	0.0	s
P05	DC injection braking-to-stop time		0.0 to 10.0	0.5	s
P06	Maximum output frequency	Used to limit the frequency. Also used as a reference frequency for the acceleration time and deceleration time.	50.0 to 120	60.0	Hz
P07	Frequency reference upper limit	Used to set the upper limit for the frequency reference.	0.1 to 120	60.0	Hz
P08	Frequency reference lower limit	Used to set the lower limit for the frequency reference.	0.0 to 120	0.0	Hz
P09	Momentary power interruption restart selection	Used to select the processing for when main-circuit low voltage protection occurs. 0: Do not continue operation. 1: Continue operation if power interruption is 0.5 s or less. 2: Always continue operation.	0 (0) 1 (1) 2 (2)	0	None
P10	Operation command selection	Used to select the command method for starting and stopping the Inverter and the direction of rotation. Key: Use Digital Operator keys. PLC: Use the STF and STR control inputs.	Key (KEY) PLC (PLC)	Key	None
P11	Frequency reference selection	Used to select the method for inputting frequency references. Key: Use Digital Operator keys. MSP: Use frequency references using multi-step speed reference 0 (SS0) and multi-step speed reference 1 (SS1). T.C: Time-shared proportional pulses using multi-step speed reference 0 (SS0).	Key (KEY) MSP (MSP) T.C (TC)	Key	None
P12	Multi-function output selection	Used to select the function of the multi-function output terminal. 0: Not allocated. 1: Zero speed (Output turned ON when the output frequency is 0 Hz or operation is stopped.) 2: Frequency matching (Output turned ON when the output frequency and the frequency reference are the same.) 3: Reverse operation (Output turned ON when the direction of rotation is set for reverse operation.)	0 (0) 1 (1) 2 (2) 3 (3)	0	None
P13	Reverse rotation prohibit selection	Used to select the operation for when a reverse rotation command is input. F.R: Forward or reverse rotation F.WD: Forward rotation only (Reverse rotation prohibited.)	F.R (FR) F.WD (FWD)	FWD	None
P14	Carrier frequency selection	Used to set the carrier frequency. 4K: 4 kHz 7K: 7 kHz	4k (4K) 7k (7K)	4K	Hz
P15	Communications unit number	Used to set the communications unit number.	0 to 99	1	None
P16	Communications baud rate	Used to set the baud rate. 24: 2.4 kbps 48: 4.8 kbps 96: 9.6 kbps 192: 19.2 kbps	2.4 (24) 4.8 (48) 9.6 (96) 19.2 (192)	9.6	kbps
P17	Communications data length	Used to set the data length. 7: 7 bits 8: 8 bits	7 (7) 8 (8)	7	bit
P18	Communications stop bits	Used to set the number of stop bits. 1: 1 bit 2: 2 bits	1 (1) 2 (2)	2	bit
P19	Communications parity	Used to set the parity. non: None evn: Even odd: Odd	non (non) evn (evn) odd (odd)	evn	None
P20	Parameter initialization	Initializes the parameter set values (except for the accumulated operating time) when "ini" is selected.	ini (ini) abt (abt)	abt	None
P21	Accumulated operating time clear	Clears the accumulated operating time to zero when "ini" is selected.	ini (ini) abt (abt)	abt	None

- Note:**
1. Set values for P06, P07, and P08 are changed in increments of 0.1 up to 99.9. From 100 and up they are changed in increments of 1.0.
 2. P15 to P19 are not displayed for Standard Models. Refer to the *Communications Manual* for details.
 3. P11 is not displayed for Communications Models.

Key Operation Flowchart

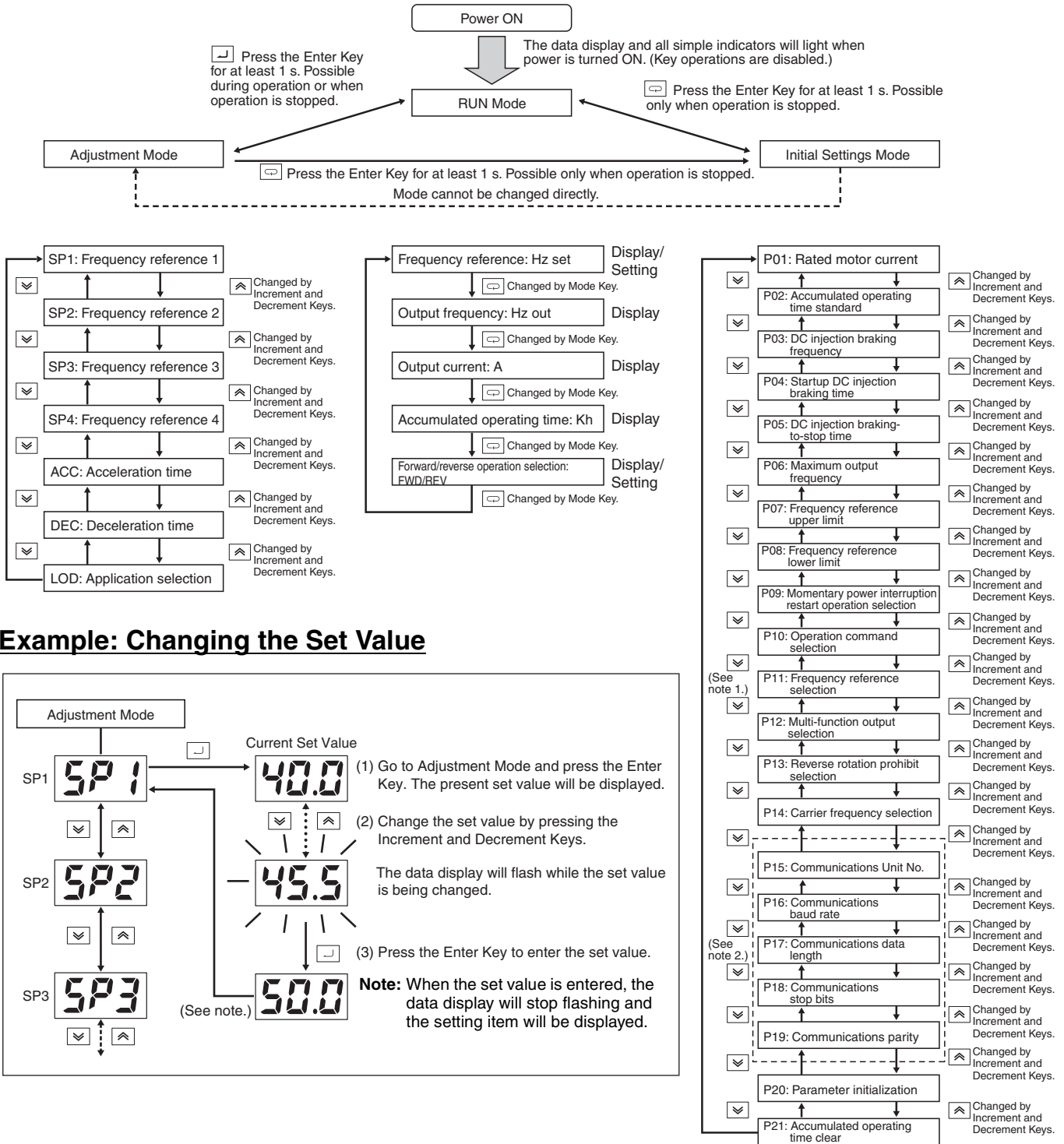

Example: Changing the Set Value

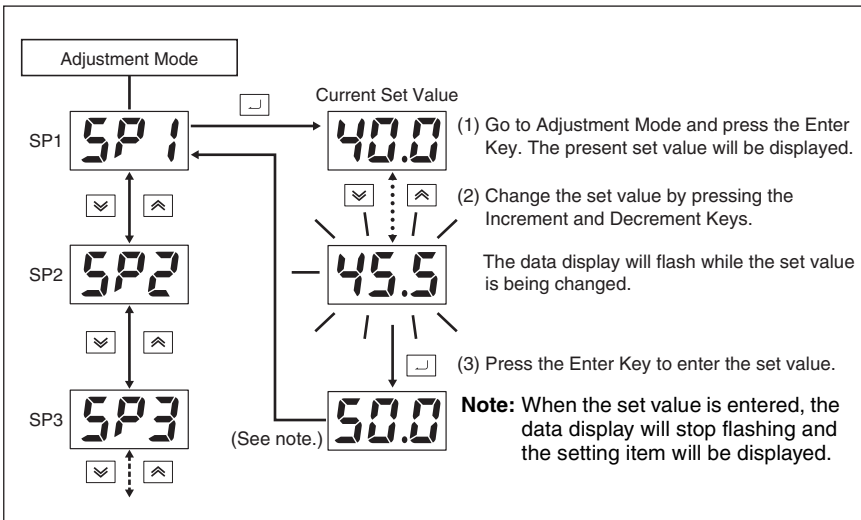

Note: 1. P11 is displayed only for Standard Models.

2. P15 to P19 are displayed only for Communications Models.

■ Setting/Monitoring Conditions in Each Mode

Mode	Setting/monitoring item	Motor operating			Motor stopped		
		Set value monitoring	Set value changes	Stop command	Set value monitoring	Set value changes	Stop command
RUN Mode	Frequency reference	○	○	○	○	○	○
	Output frequency	○	×	○	○	×	○
	Output current	○	×	○	○	×	○
	Accumulated operating time	○	×	○	○	×	○
	Forward/reverse operation selection	○	○	○	○	○	○
Adjustment Mode	Frequency references 1 to 4	○	○	○	○	○	○
	Acceleration/deceleration times	○	×	○	○	○	○
	Application selection	○	×	○	○	○	○
Initial Settings Mode	P01 to P21	×	×	×	○	○	×

Note: If the power supply is interrupted while a setting is being changed, the change will not be applied when the power supply is turned back ON.

Protective Functions

■ Fault Displays and Countermeasures

Fault display	Fault and meaning	Cause	Countermeasure
E02	Overcurrent A momentary overcurrent (approx. 250% of rated output current) was output. An Inverter overload (150% of rated output current for 1 min) was detected.	A short-circuit or ground fault has occurred at the Inverter output.	Check and correct the motor power cable.
		An error occurred in the machine.	Remove the cause of the machine error.
		The motor capacity is too large for the Inverter.	Reduce the motor capacity to the maximum permissible motor capacity or less.
		The Inverter capacity is insufficient.	Increase the Inverter capacity.
		The magnetic contactor on the output side of the Inverter has been opened and closed.	Rearrange the sequence so that the magnetic contactor will not open or close while the Inverter is outputting a current.
		The acceleration/deceleration time is too short.	Increase the acceleration/deceleration time.
		The output circuit of the Inverter is damaged.	Replace the Inverter.
		The load is too large.	Reduce the load.
E03	Motor overload The electronic thermal relay actuated the motor overload protective function.	The load is too large.	<ul style="list-style-type: none"> • Reduce the load. • Increase the motor capacity.
		The acceleration/deceleration time is too short.	Increase the acceleration/deceleration time.
		The value in P01 for rated motor current is incorrect.	Check the motor nameplate and set P01 to the rated current.
		The Inverter is driving more than one motor.	Disable the motor overload detection function and install a thermal relay for each of the motor.
E04	Overvoltage The main circuit DC voltage reached the overvoltage detection level (410 V DC min.) during Inverter operation.	The deceleration time is too short.	Increase the deceleration time.
		The power supply voltage is too high.	Decrease the voltage to within specifications.
		There is excessive regenerative energy due to overshooting at the time of acceleration. Suppress the overshooting as much as possible.	Suppress the overshooting as much as possible.
E05	Main circuit undervoltage The main circuit DC voltage reached the undervoltage detection level (200 V DC) during Inverter operation.	Power supply to the Inverter has phase loss or the power cable is disconnected.	Check the above and take necessary countermeasures.
		Incorrect power supply voltage	Make sure that the power supply voltage is within specifications.
		Momentary power interruption has occurred.	<ul style="list-style-type: none"> • Use the momentary power interruption restart. (Set P09 to 1 or 2.) • Improve the power supply.
		The internal circuitry of the Inverter is damaged.	Replace the Inverter.
E06	Radiation fin overheating The temperature of the radiation fin in the Inverter has exceeded the specified value during Inverter operation.	The ambient temperature is too high.	Ventilate the Inverter or install a cooling unit.
		The Inverter is installed too close to other devices.	Increase the separation from other devices.
		The load is too large.	<ul style="list-style-type: none"> • Reduce the load. • Increase the Inverter capacity.
		The acceleration/deceleration time is too short.	Increase the acceleration/deceleration time.
		The ventilation is obstructed.	Change the location of the Inverter to meet the installation conditions.
		The cooling fan of the Inverter does not work. (The cooling fan's service life has expired, or the fan is broken.)	Replace the cooling fan. (Applies to Inverters with fans.)

Fault display	Fault and meaning	Cause	Countermeasure
E07	Cooling fan fault The cooling fan has been locked (stopped) or the rotation speed is down by 30% or more.	The cooling fan wiring has a fault.	Turn OFF the Inverter, remove the Inverter, and check and repair the wiring.
		The cooling fan is not in good condition.	Check and remove the foreign material or dust on the fan.
		The cooling fan has a fault or has expired its service life.	Replace the fan.
E08	Braking IGBT fault The brake IGBT is malfunctioning.	The IGBT is damaged.	Turn OFF the Inverter's power supply immediately and replace the Inverter.
E09	Accumulated operating time alarm	The Inverter's accumulated operating time has reached the value set in the accumulated operating time standard time (P02) .	To clear this alarm, set the accumulated operating time clear (P21) to ini or increase the value set for the accumulated operating time standard time (P02).
E01	Memory fault A fault was detected in the Inverter's internal memory.	Internal circuit fault	If the fault persists even after the power has been turned OFF and back ON, then replace the Inverter.
E5E	EEPROM write error	A power interruption has occurred during an overload.	Turn the power supply OFF and back ON again. (The immediately previous accumulated operating time will not be incremented.)
Not lit	Power supply fault, power supply undervoltage, brake power supply fault, or hardware error	No power supply is provided.	Check and correct the power supply wire and voltage.
		Terminal screws are loosened.	Check and tighten the terminal screws.
		The Inverter is damaged.	Replace the Inverter.

Warranty and Application Considerations

Read and Understand this Catalog

Please read and understand this catalog before purchasing the products. Please consult your OMRON representative if you have any questions or comments.

Warranty and Limitations of Liability

WARRANTY

OMRON's exclusive warranty is that the products are free from defects in materials and workmanship for a period of one year (or other period if specified) from date of sale by OMRON.

OMRON MAKES NO WARRANTY OR REPRESENTATION, EXPRESS OR IMPLIED, REGARDING NON-INFRINGEMENT, MERCHANTABILITY, OR FITNESS FOR PARTICULAR PURPOSE OF THE PRODUCTS. ANY BUYER OR USER ACKNOWLEDGES THAT THE BUYER OR USER ALONE HAS DETERMINED THAT THE PRODUCTS WILL SUITABLY MEET THE REQUIREMENTS OF THEIR INTENDED USE. OMRON DISCLAIMS ALL OTHER WARRANTIES, EXPRESS OR IMPLIED.

LIMITATIONS OF LIABILITY

OMRON SHALL NOT BE RESPONSIBLE FOR SPECIAL, INDIRECT, OR CONSEQUENTIAL DAMAGES, LOSS OF PROFITS, OR COMMERCIAL LOSS IN ANY WAY CONNECTED WITH THE PRODUCTS, WHETHER SUCH CLAIM IS BASED ON CONTRACT, WARRANTY, NEGLIGENCE, OR STRICT LIABILITY.

In no event shall the responsibility of OMRON for any act exceed the individual price of the product on which liability is asserted.

IN NO EVENT SHALL OMRON BE RESPONSIBLE FOR WARRANTY, REPAIR, OR OTHER CLAIMS REGARDING THE PRODUCTS UNLESS OMRON'S ANALYSIS CONFIRMS THAT THE PRODUCTS WERE PROPERLY HANDLED, STORED, INSTALLED, AND MAINTAINED AND NOT SUBJECT TO CONTAMINATION, ABUSE, MISUSE, OR INAPPROPRIATE MODIFICATION OR REPAIR.

Application Considerations

SUITABILITY FOR USE

OMRON shall not be responsible for conformity with any standards, codes, or regulations that apply to the combination of products in the customer's application or use of the products.

Take all necessary steps to determine the suitability of the product for the systems, machines, and equipment with which it will be used.

Know and observe all prohibitions of use applicable to this product.

NEVER USE THE PRODUCTS FOR AN APPLICATION INVOLVING SERIOUS RISK TO LIFE OR PROPERTY WITHOUT ENSURING THAT THE SYSTEM AS A WHOLE HAS BEEN DESIGNED TO ADDRESS THE RISKS, AND THAT THE OMRON PRODUCTS ARE PROPERLY RATED AND INSTALLED FOR THE INTENDED USE WITHIN THE OVERALL EQUIPMENT OR SYSTEM.

Disclaimers

CHANGE IN SPECIFICATIONS

Product specifications and accessories may be changed at any time based on improvements and other reasons. Consult with your OMRON representative at any time to confirm actual specifications of purchased product.

DIMENSIONS AND WEIGHTS

Dimensions and weights are nominal and are not to be used for manufacturing purposes, even when tolerances are shown.

ALL DIMENSIONS SHOWN ARE IN MILLIMETERS.

To convert millimeters into inches, multiply by 0.03937. To convert grams into ounces, multiply by 0.03527.

Cat. No. I909-E1-01 **In the interest of product improvement, specifications are subject to change without notice.**

OMRON Corporation

Industrial Automation Company

Control Devices Division H.Q.

Motion Control Department

Shiokoji Horikawa, Shimogyo-ku,

Kyoto, 600-8530 Japan

Tel: (81)75-344-7173/Fax: (81)75-344-7149

Printed in Japan

0606-1M (0606) (C)