

# 3G3MX2

## With Machine Automation Mentality

- Current vector Control.
- High Starting torque: 200% at 0.5 Hz.
- Double rating VT 120%/1 min and CT 150% /1 min.
- Speed range up to 1,000 Hz.
- Positioning functionality.
- Safety embedded compliant with ISO 13849-1: 2006 (PLd)  
(under application) (double input circuit and external device monitor)
- Modbus communications.
- PC Configuration tool: CX-Drive.



## Interpreting Model Numbers

**3G3MX2-A**

3G3MX2

Voltage class

B	1-phase 200 VAC (200-V class)
2	3-phase 200 VAC (200-V class)
4	3-phase 400 VAC (400-V class)

Max. applicable motor capacity (CT)

001	0.1 kW	037	3.7 kW
002	0.2 kW	040	4.0 kW
004	0.4 kW	055	5.5 kW
007	0.75 kW	075	7.5 kW
015	1.5 kW	110	11 kW
022	2.2 kW	150	15 kW
030	3.0 kW		

## Ordering Information

### International Standards

- The standards are abbreviated as follows: U: UL, U1: UL (Class I Division 2 Products for Hazardous Locations), C: CSA, UC: cULus, UC1: cULus (Class I Division 2 Products for Hazardous Locations), CU: cUL, N: NK, L: Lloyd, and CE: EC Directives.
- Contact your OMRON representative for further details and applicable conditions for these standards.

## 3G3MX2 Inverter Models

Rated voltage	Enclosure ratings	Max. applicable motor capacity		Model
		CT: Heavy load	VT: Light load	
3-phase 200 VAC	IP20	0.1kW	0.2 kW	3G3MX2-A2001
		0.2 kW	0.4 kW	3G3MX2-A2002
		0.4 kW	0.75 kW	3G3MX2-A2004
		0.75 kW	1.1 kW	3G3MX2-A2007
		1.5 kW	2.2 kW	3G3MX2-A2015
		2.2 kW	3.0 kW	3G3MX2-A2022
		3.7 kW	5.5 kW	3G3MX2-A2037
		5.5 kW	7.5 kW	3G3MX2-A2055
		7.5 kW	11 kW	3G3MX2-A2075
		11 kW	15 kW	3G3MX2-A2110
3-phase 400 VAC	IP20	15 kW	18.5 kW	3G3MX2-A2150
		0.4 kW	0.75 kW	3G3MX2-A4004
		0.75 kW	1.5 kW	3G3MX2-A4007
		1.5 kW	2.2 kW	3G3MX2-A4015
		2.2 kW	3.0 kW	3G3MX2-A4022
		3.0 kW	4.0 kW	3G3MX2-A4030
		4.0 kW	5.5 kW	3G3MX2-A4040
		5.5 kW	7.5 kW	3G3MX2-A4055
		7.5 kW	11 kW	3G3MX2-A4075
1-phase 200 VAC	IP20	11 kW	15 kW	3G3MX2-A4110
		15 kW	18.5 kW	3G3MX2-A4150
		0.1 kW	0.2 kW	3G3MX2-AB001
		0.2 kW	0.4 kW	3G3MX2-AB002
		0.4 kW	0.55 kW	3G3MX2-AB004
		0.75 kW	1.1 kW	3G3MX2-AB007
		1.5 kW	2.2 kW	3G3MX2-AB015
		2.2 kW	3.0 kW	3G3MX2-AB022

For option, refer to 15 page.

## Software

Product name	Specifications	Number of licenses	Media	Model	Standards
CX-One FA Integrated Tool Package Ver. 3.□	The CX-One is a package that integrates the Support Software for OMRON PLCs and components. CX-One runs on the following OS. Windows 2000 (Service Pack 3 or higher), XP, or Vista. CX-One Ver.3.□ includes CX-Drive Ver.1.□. For details, refer to the CX-One catalog (Cat. No. R134).	1 license *1	CD	CXONE-AL01C-V3	---
			DVD *2	CXONE-AL01D-V3	
	CX-Drive can still be ordered individually in the following model numbers.				
CX-Drive Ver.1.□	Application software to set and control data for Inverters and Servos. OS: Windows 2000 (Service Pack 3a or higher), XP, or Vista	1 license	CD	WS02-DRVC1	---

\*1. Multi licenses are available for the CX-One (3, 10, 30, or 50 licenses).

\*2. When purchasing the DVD format, verify the computer model and DVD drive specifications before purchasing.

## CX-Drive connection cable

Specifications	Description
USB Cable (USB1.1, mini-B connector) Max. 2.0 m	General purpose USB cable can be used.

## Standard Specification List

### 3-phase 200 V Class

Function name			3-phase 200 V										
Model name (3G3MX2-)			A2001	A2002	A2004	A2007	A2015	A2022	A2037	A2055	A2075	A2110	A2150
Applicable motor capacity	kW	CT	0.1	0.2	0.4	0.75	1.5	2.2	3.7	5.5	7.5	11	15
		VT	0.2	0.4	0.75	1.1	2.2	3.0	5.5	7.5	11	15	18.5
	HP	CT	1/8	1/4	1/2	1	2	3	5	7 1/2	10	15	20
		VT	1/4	1/2	1	1 1/2	3	4	7 1/2	10	15	20	25
Rated output capacity [kVA]	200 V	CT	0.2	0.5	1.0	1.7	2.7	3.8	6.0	8.6	11.4	16.2	20.7
		VT	0.4	0.6	1.2	2.0	3.3	4.1	6.7	10.3	13.8	19.3	23.9
	240 V	CT	0.3	0.6	1.2	2.0	3.3	4.5	7.2	10.3	13.7	19.5	24.9
		VT	0.4	0.7	1.4	2.4	3.9	4.9	8.1	12.4	16.6	23.2	28.6
Rated input voltage			3-phase 200 V - 15% to 240 V + 10%, 50/60 ± 5%										
Rated output voltage			3-phase 200 to 240 V (The output cannot exceed the incoming voltage).										
Rated output current [A]	CT		1.0	1.6	3.0	5.0	8.0	11.0	17.5	25.0	33.0	47.0	60.0
	VT		1.2	1.9	3.5	6.0	9.6	12.0	19.6	30.0	40.0	56.0	69.0
Short-time deceleration braking torque (%) (Discharge Resistor not connected)			50	50	50	50	50	20	20	20	20	10	10
Braking Resistor circuit *	Regenerative braking		Built-in Braking Resistor circuit (separate Discharge Resistor)										
	Min. connectable resistance [ $\Omega$ ]		100	100	100	50	50	35	35	20	17	17	10
Weight [kg]			1.0	1.0	1.1	1.2	1.6	1.8	2.0	3.3	3.4	5.1	7.4
Dimensions (width × height) [mm]			68 × 128				108 × 128		140 × 128	140 × 260		180 × 296	220 × 350
Dimensions (depth) [mm]			109		122.5	145.5	170.5		170.5	155		175	

\* The BRD usage is 10%.

### 3-phase 400 V Class

Function name			3-phase 400 V										
Model name (3G3MX2-)			A4004	A4007	A4015	A4022	A4030	A4040	A4055	A4075	A4110	A4150	
Applicable motor capacity	kW	CT	0.4	0.75	1.5	2.2	3.0	4.0	5.5	7.5	11	15	
		VT	0.75	1.5	2.2	3.0	4.0	5.5	7.5	11	15	18.5	
	HP	CT	1/2	1	2	3	4	5	7 1/2	10	15	20	
		VT	1	2	3	4	5	7 1/2	10	15	20	25	
Rated output capacity [kVA]	380 V	CT	1.1	2.2	3.1	3.6	4.7	6.0	9.7	11.8	15.7	20.4	
		VT	1.3	2.6	3.5	4.5	5.7	7.3	11.5	15.1	20.4	25.0	
	480 V	CT	1.4	2.8	3.9	4.5	5.9	7.6	12.3	14.9	19.9	25.7	
		VT	1.7	3.4	4.4	5.7	7.3	9.2	14.5	19.1	25.7	31.5	
Rated input voltage			3-phase 380 V - 15% to 480 V + 10%, 50/60 ± 5%										
Rated output voltage			3-phase 380 to 480 V (The output cannot exceed the incoming voltage).										
Rated output current [A]	CT		1.8	3.4	4.8	5.5	7.2	9.2	14.8	18.0	24.0	31.0	
	VT		2.1	4.1	5.4	6.9	8.8	11.1	17.5	23.0	31.0	38.0	
Short-time deceleration braking torque (%) (Discharge Resistor not connected)			50	50	50	20	20	20	20	20	10	10	
Braking Resistor circuit *	Regenerative braking		Built-in Braking Resistor circuit (separate Discharge Resistor)										
	Min. connectable resistance [ $\Omega$ ]		180	180	180	100	100	100	70	70	70	35	
Weight [kg]			1.5	1.6	1.8	1.9	1.9	2.1	3.5	3.5	4.7	5.2	
Dimensions (width × height) [mm]			108 × 128				140 × 128	140 × 260		180 × 296			
Dimensions (depth) [mm]			143.5	170.5			170.5	155		175			

\* The BRD usage is 10%.

# 3G3MX2

## 1-phase 200 V Class

Function name			1-phase 200 V					
Model name (3G3MX2-)			AB001	AB002	AB004	AB007	AB015	AB022
Applicable motor capacity	kW	CT	0.1	0.2	0.4	0.75	1.5	2.2
		VT	0.2	0.4	0.55	1.1	2.2	3.0
	HP	CT	1/8	1/4	1/2	1	2	3
		VT	1/4	1/2	3/4	1 1/2	3	4
Rated output capacity [kVA]	200 V	CT	0.2	0.5	1.0	1.7	2.7	3.8
		VT	0.4	0.6	1.2	2.0	3.3	4.1
	240 V	CT	0.3	0.6	1.2	2.0	3.3	4.5
		VT	0.4	0.7	1.4	2.4	3.9	4.9
Rated input voltage			1-phase 200 V - 15% to 240 V + 10%, 50/60 Hz ± 5%					
Rated output voltage			3-phase 200 to 240 V (The output cannot exceed the incoming voltage).					
Rated output current [A]	CT		1.0	1.6	3.0	5.0	8.0	11.0
	VT		1.2	1.9	3.5	6.0	9.6	12.0
Short-time deceleration braking torque (%) (Discharge Resistor not connected)			50	50	50	50	50	20
Braking Resistor circuit *	Regenerative braking		Built-in Braking Resistor circuit (separate Discharge Resistor)					
	Min. connectable resistance [ $\Omega$ ]		100	100	100	50	50	35
Weight [kg]			1.0	1.0	1.1	1.6	1.8	1.8
Dimensions (width × height) [mm]			68 × 128			108 × 128		
Dimensions (depth) [mm]			109	122.5	170.5			

\* The BRD usage is 10%.

## Common Specifications

Function name		Specifications
Enclosure ratings *1		Open type (IP20)
Control	Control method	Phase-to-phase sinusoidal modulation PWM
	Output frequency range *2	0.10 to 400 Hz (or 1,000 Hz in the high-frequency mode; restrictions apply)
	Frequency precision *3	Digital command: $\pm 0.01\%$ of the max. frequency, Analog command: $\pm 0.2\%$ of the max. frequency (25°C $\pm$ 10°C)
	Frequency setting resolution	Digital setting: 0.01 Hz, Analog setting: One-thousandth of the maximum frequency
	Voltage/Frequency characteristics	V/f characteristics (constant/reduced torque) Sensorless vector control, V/f control with speed feedback
	Overload current rating	Heavy load rating (CT): 150%/60 s Light load rating (VT): 120%/60 s
	Instantaneous overcurrent protection	200% of the value of heavy load rating (CT)
	Acceleration/Deceleration time	0.01 to 3600 s (linear/curve selection), acceleration/deceleration 2 setting available
	Carrier frequency adjustment range	2 to 15 kHz (with derating)
	Starting torque	200%/0.5 Hz (sensorless vector control)
External DC injection braking		Starts at a frequency lower than that in deceleration via the STOP command, at a value set lower than that during operation, or via an external input. (Level and time settable).
Protective functions		Overcurrent, overvoltage, undervoltage, electronic thermal, temperature error, ground fault overcurrent at power-on status, rush current prevention circuit, overload limit, incoming overvoltage, external trip, memory error, CPU error, USP error, communication error, overvoltage suppression during deceleration, protection upon momentary power outage, emergency cutoff, etc.
Input signal	Frequency settings	Digital Operator External analog input signal: Variable resistance/0 to 10 VDC/4 to 20 mA, Modbus communication (Modbus-RTU)
	RUN/STOP command	Digital Operator External digital input signal (3-wire input supported), Modbus communication (Modbus-RTU)
	Multi-function input	7 points (Selectable from 59 functions)
	Analog input	2 points (Voltage FV terminal: 10 bits/0 to 10 V, Current FI terminal: 10 bits/4 to 20 mA)
	Pulse input	1 point (RP terminal: 32 kHz max., 5 to 24 VDC)
Output signal	Multi-function output	2 points (P1/EDM, P2; selectable from 43 functions)
	Relay output	1 point (1c contact: MC, MA, MB; selectable from 43 functions)
	Analog output (Frequency monitor)	1 point (AM terminal: Voltage 10 bits/0 to 10 V) (Frequency, current selectable)
	Pulse output	1 point (MP terminal: 32 kHz max., 0 to 10 V)
Communications	RS-422	RJ45 connector (for Digital Operator)
	RS-485	Control circuit terminal block, Modbus communication (Modbus-RTU)
	USB	USB1.1, mini-B connector
Other functions		AVR function, V/f characteristics switching, upper/lower limit, 16-step speeds, starting frequency adjustment, jogging operation, carrier frequency adjustment, PID control, frequency jump, analog gain/bias adjustment, S shape acceleration/deceleration, electronic thermal characteristics, level adjustment, restart function, torque boost function, fault monitor, soft lock function, frequency conversion display, USP function, motor 2 control function, UP/DWN, overcurrent suppression function, etc.
General specifications	Ambient temperature	-10 to 50°C (However, derating is required).
	Ambient storage temperature	-20°C to 65°C (short-time temperature during transport)
	Humidity	20% to 90% RH (with no condensation)
	Vibration	5.9 m/s <sup>2</sup> (0.6G), 10 to 55 Hz
	Location	At a maximum altitude of 1,000 m; indoors (without corrosive gases or dust)
Options		DC reactor, AC reactor, radio noise filter, input noise filter, output noise filter, regenerative braking unit, Braking Resistor, EMC noise filter, etc.

**Note:** 1. The applicable motor is a 3-phase standard motor. For using any other type, be sure that the rated current does not exceed that of the Inverter.  
2. Output voltage decreases according to the level of the power supply voltage.  
3. The braking torque at the time of capacitor feedback is an average deceleration torque at the shortest deceleration (when it stops from 50 Hz). It is not a continuous regeneration torque. Also, the average deceleration torque varies depending on the motor loss. The value is reduced in operation over 50 Hz.

\*1. Protection method complies with JEM 1030.

\*2. To operate the motor at over 50/60 Hz, contact the motor manufacturer to find out the maximum allowable speed of revolution.

\*3. For the stable control of the motor, the output frequency may exceed the maximum frequency set in A004 (A204) by 2 Hz max.

## Terminal Block Specifications

### Names of Parts Inside the Terminal Block Cover

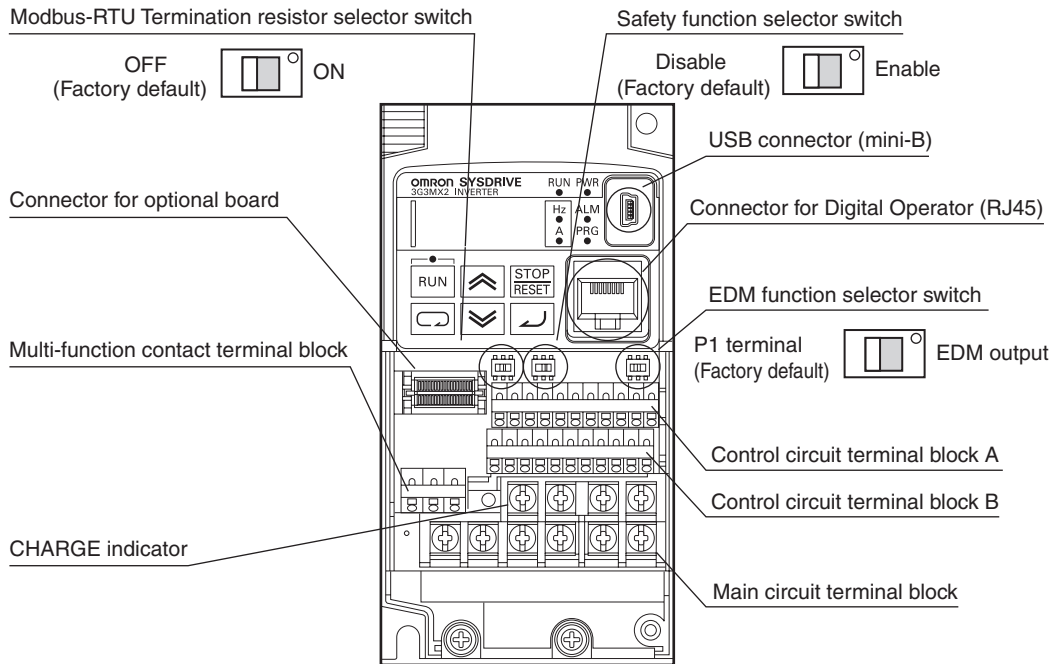

Name	Description
Modbus-RTU Termination resistor selector switch	Use this Terminal Resistor selector switch for RS-485 terminals on the control circuit terminal block. When this switch is turned ON, the internal 200 Ω Resistor is connected.
Safety function selector switch	Turn this switch ON when using the safety function. Turn OFF the power before turning this switch ON/OFF. For details, refer to User's Manual (I570).
EDM function selector switch	Turn this switch ON when using the EDM output of the safety function. Turn OFF the power before turning this switch ON/OFF. For details, refer to User's Manual (I570).
USB connector	Use this mini-B USB connector to connect a PC. Even when the Inverter is being operated by a PC, etc., via USB connection, it can still be operated using the Digital Operator.
Connector for Digital Operator	Use this connector to connect the Digital Operator.
Connector for optional board	Use this connector to mount the optional board. (The optional board will be released soon.)
Control circuit terminal blocks A and B	These terminal blocks are used to connect various digital/analog input and output signals for inverter control, etc.
Multi-function contact terminal block	Use this SPDT contact terminal block for relay outputs.
Main circuit terminal block	Use this terminal block to connect an output to the motor and Braking Resistor, etc. Also, use this terminal block to connect the inverter to the main power supply.
CHARGE indicator (Charge indicator LED)	This LED indicator is lit if the DC voltage of the main circuit (between terminals P/+2 and N/-) remains approx. 45 V or above after the power has been cut off. Before wiring, etc. confirm that the Charge LED indicator is turned OFF.

## Main Circuit Terminals Specifications

### [Main Circuit Terminal Block]

3G3MX2-A2001 to A2037

3G3MX2-A4004 to A4040

3G3MX2-AB001 to AB022

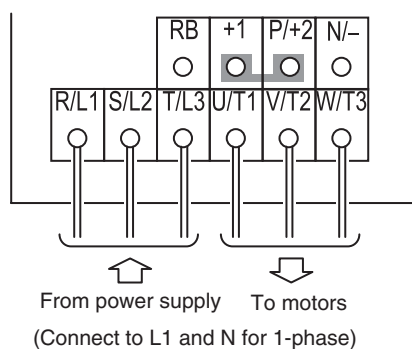

### [Main Circuit Terminal Block]

3G3MX2-A2001 to A2037

3G3MX2-A4004 to A4040

3G3MX2-AB001 to AB022

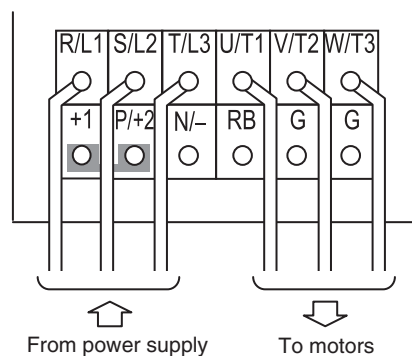

Terminal symbol	Terminal name	Description
R/L1	Main power supply input terminal	Connect the input AC power supply. In the case of a 1-phase 200 V power supply, connect to L1 and N.
S/L2		
T/L3		
U/T1	Inverter output terminal	Connect a 3-phase motor.
V/T2		
W/T3		
+1	DC reactor connection terminal	Remove the shorting bar between terminals +1 and P/+2, and connect the optional DC reactor.
P/+2		
P/+2	Braking Resistor connection terminal	Connect optional braking resistors. (If a braking torque is required)
RB		
P/+2	Regenerative braking unit connection terminal	Connect optional regenerative braking units. (When braking torque is required or the built-in braking circuit is not sufficient)
N/-		
G ⊕	Ground terminal	This is a ground terminal. Connect this terminal to the ground. Provide Class D grounding for 200 V class models, and class C grounding for 400 V class models. On 200 V class models of 3.7 kW or below and 400 V class models of 4.0 kW or below, the ground terminal is located on the cooling fin.

## Control Circuit Terminals Specifications

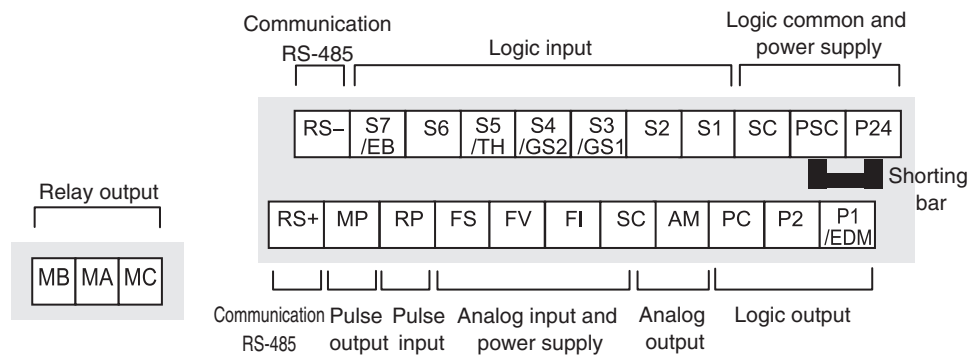

		Terminal symbol	Terminal name	Description	Specifications
Analog	Power supply	SC	Input signal common	This is a common terminal used by the internal power supply, digital input and analog input/output terminals.	
		FS	Frequency reference power supply	10 VDC power supply for the FV terminal.	Allowable max. current: 7 mA
	Frequency setting input	FV	Frequency reference input terminal (analog voltage input)	Use this terminal if the frequency reference is provided by 0 to 10 VDC voltage input.	Input impedance Approx. 10 kΩ Allowable input voltage range -0.3 to +12 VDC
		FI	Frequency reference terminal (analog current input)	Use this terminal if the frequency reference is provided by 4 to 20 mA current input.	Input impedance 100 Ω Allowable input range 0 to 24 mA
	Sensor input	S5/TH	External thermistor input (also used as multi-function input terminal)	Connect an external thermistor between the SCs, to trip the Inverter when a temperature error occurs. (The inverter will trip when the input from thermistor is approx. 3 kΩ or higher.) Since this input is also used as the multi-function input terminal, setting of C005 is required. For details, refer to User's Manual (I570).	PTC type
Output	AM	Multi-function analog output (voltage)	Specified signals can be output using voltage signals of 0 to 10 VDC.	AM	
Digital	Power supply	SC	Input signal common	This is a common terminal used by the internal power supply, digital input and analog input/output terminals.	
		P24	Power supply terminal for input signal	24 VDC power supply for contact input signal. This is used as a common terminal if the source logic is input.	Allowable max. current: 100 mA
		PSC	Power supply terminal for input terminal	Sink logic input: Shorted with P24 Source logic input: Shorted with SC To drive the contact input using an external power supply, remove the shorting bar. For details, refer to User's Manual (I570).	
	Input Contact	S7/EB S6 S5/TH S4/GS2 S3/GS1 S2 S1	Multi-function input terminal	Select 7 functions from among 59, and allocate them to terminals S1 through S7/EB. Both sink and source logics are supported. For details, refer to User's Manual (I570).	Voltage between each input and PSC ON voltage: 18 V min. OFF voltage: 3 V max. Allowable max. voltage: 27 VDC Load current: 5 mA (at 24 V)
S4/GS2 S3/GS1		Safety input	Enabled when the safety function selector switch is turned ON. For details, refer to User's Manual (I570).		

			Terminal symbol	Terminal name	Description	Specifications
Digital	Input	Pulse	RP	Pulse input-A	A pulse input for frequency setting. (Take note that the internal circuit is different from input terminals S7/EB.)	Input pulse 32 kHz max. Voltage between input and SC ON voltage: 4 V min. OFF voltage: 1 V max. Allowable max. voltage: 27 VDC
			S7/EB	Pulse input-B	A pulse input for frequency setting. (Take note that the internal circuit is different from input terminal RP.)	Input pulse 1.8 kHz max. ON voltage: 18 V min. OFF voltage: 3 V max. Allowable max. voltage: 27 VDC Load current: 5 mA (at 24 V)
	Output	Open collector	P1/EDM P2	Multi-function output terminal	Select 2 functions from among 43, and allocate them to terminals P1 through P2. Both sink and source logics are supported. For details, refer to User's Manual (I570).	Open collector output Between each terminal and PC Allowable max. voltage: 27 V Allowable max. current: 50 mA Voltage drop when ON: 4 V max.
			P1/EDM	Safety monitor	Enabled when the EDM function selector switch is ON. For details, refer to "Safety Function" on page 5-167.	
		Relay	MA MB	Relay output terminal	Select the desired functions from among 43 functions, and allocate them to these terminals. SPDT contact. The factory default of Relay Output (MA, MB) Contact Selection (C036) is NC contact between MA-MC, and NO contact between MB-MC.	Max. contact capacity MA-MC: 250 VAC, 2 A (resistance) 0.2 A (induction) MB-MC: 250 VAC, 1 A (resistance) 0.2 A (induction) Contact min. capacity 100 VAC, 10mA 5 VDC, 100mA
	MC		Relay output common			
		Pulse	MP	Pulse output	Pulses are output.	Output pulse: 32 kHz max. Output voltage: 10 VDC Allowable max. current: 2 mA
Serial communication		RS+ RS-	Modbus port (RS-485)	RS-485 port RS+ RS-485 differential (+) signal RS- RS-485 differential (-) signal	Max. speed: 115.2 kbps Built-in Terminal Resistor: 200 Ω Slide switch selection	

### Switching Method for Input Control Logics

Multi-function input terminals are set to sink logic at the factory.

To switch the input control logic to source logic, remove the shorting bar between terminals P24 and PSC on the control circuit terminal block, and connect it between terminals PSC and SC.

(1) Sink logic

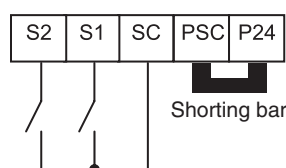

(2) Source logic

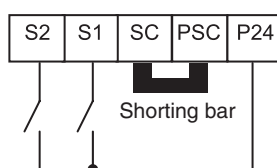

# Connection Diagram

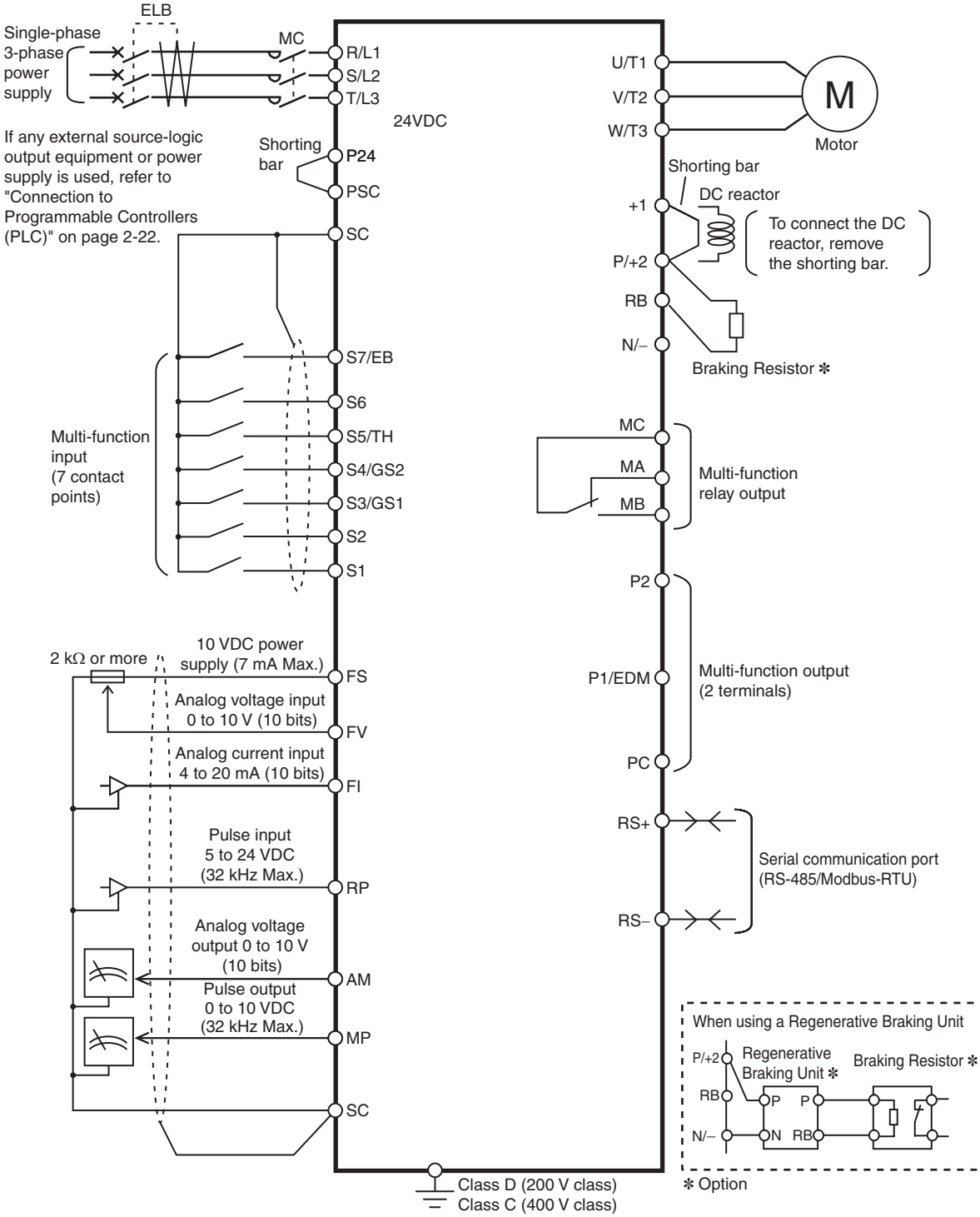

**Note:** 1. Connect a single-phase 200 V AC input to terminals L1 and N.  
 2. Factory default settings for relay output are NC contact for MA and NO contact for MB.

## Names of Parts and their Descriptions

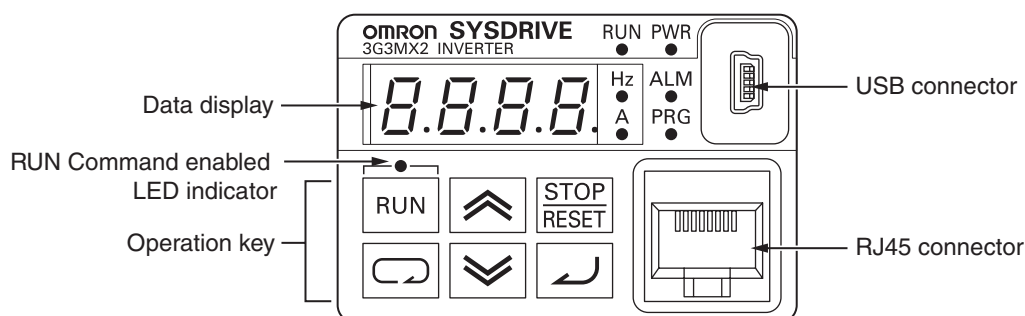

	Name	Description
	POWER LED	Lit (green) while the Inverter is receiving power.
	ALARM LED	Lit (red) when the Inverter trips. For information on how to reset the trip, refer to User's Manual (I570).
	PROGRAM LED indicator	Lit (green) when the displayed data (set value) can be changed. Blinks if the set value is invalid. Refer to User's Manual (I570).
	RUN (during RUN) LED indicator	Lit (green) when the Inverter is running. (Lit when there is either a "valid RUN command" or "inverter output." Accordingly, it is also lit when a RUN command is issued at a set frequency of 0 Hz or while the motor is decelerating after the RUN command is turned OFF.)
	Monitor LED indicator (Hz)	Lit (green) when the displayed data is frequency.
	Monitor LED indicator (A)	Lit (green) when the displayed data is current.
	RUN Command enabled LED indicator	Lit (green) when the RUN command is set to the Digital Operator. (The RUN key on the Digital Operator is enabled.)
	Display	Various parameters, frequency/set value and other data are displayed (red).
	RUN key	Runs the Inverter. Take note that this key is enabled only when the RUN command destination is the Digital Operator.
	STOP/RESET key	This key decelerates the Inverter to a stop. (Although the STOP/RESET key is enabled even when a RUN command is issued to a destination other than the Digital Operator (factory default), it can be disabled by a Setting (b087).) If the Inverter is already tripped, the trip will be reset (return from the tripping).
	Mode key	Parameter is displayed: Move to the beginning of the next function group. Data is displayed: Cancel the setting and return to the parameter display. Individual input mode: Move the blinking digit to the left. Regardless of the displayed screen, pressing and holding this key (for 1 second or more) displays the data for Output Frequency Monitor (d001).
	Increment key Decrement key	These keys are used to increment/decrement a parameter or set data. Pressing and holding each key increases the incrementing/decrementing speed. Pressing the Increment and Decrement keys together activates the "Individual Input MODE" where each digit can be edited independently.
	Enter key	Parameter is displayed: Move to the data display. Data is displayed: Confirm/store the setting (in the EEPROM) and return to the parameter display. Individual input mode: Move the blinking digit to the right.
	USB connector	Use this connector (mini-B type) to connect a PC. The Inverter can still be operated from the Digital Operator even when it is being operated using a PC, etc., via USB communication.
	RJ45 connector	Use this connector (RS-422) to connect the optional Remote Operator. Once the Remote Operator is connected, the keys on the main unit become disabled. In this case, use b150 to set the item to be displayed.

## Dimensions

- 3G3MX2-AB001
- 3G3MX2-AB002
- 3G3MX2-AB004
- 3G3MX2-A2001
- 3G3MX2-A2002
- 3G3MX2-A2004
- 3G3MX2-A2007

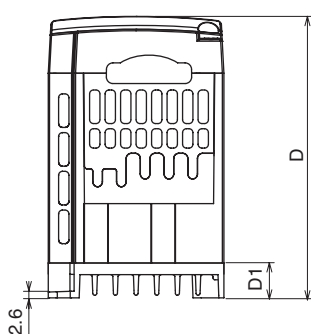
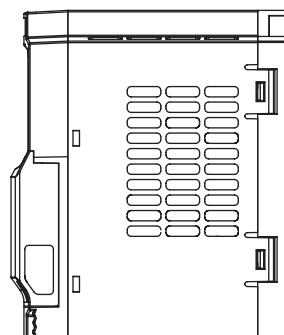
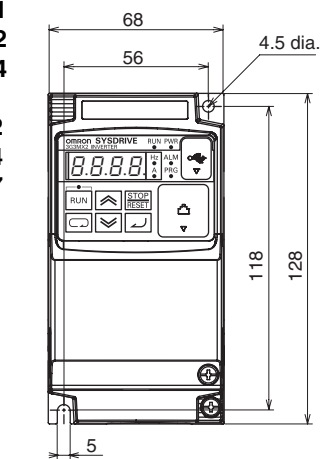

Power supply	Model	W [mm]	H [mm]	D [mm]	D1 [mm]
1-phase 200 V	3G3MX2-AB001	68	128	109	13.5
	3G3MX2-AB002			122.5	27
	3G3MX2-AB004			109	13.5
3-phase 200 V	3G3MX2-A2001	68	128	109	13.5
	3G3MX2-A2002			122.5	27
	3G3MX2-A2004			145.5	50
	3G3MX2-A2007				

- 3G3MX2-AB007
- 3G3MX2-AB015
- 3G3MX2-AB022
- 3G3MX2-A2015
- 3G3MX2-A2022
- 3G3MX2-A4004
- 3G3MX2-A4007
- 3G3MX2-A4015
- 3G3MX2-A4022
- 3G3MX2-A4030

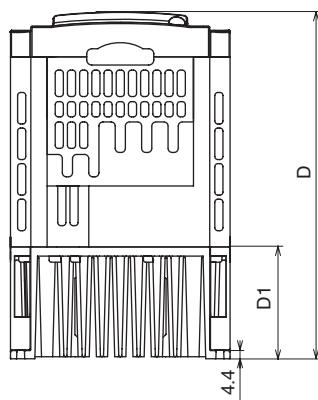
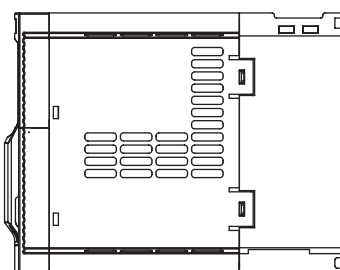
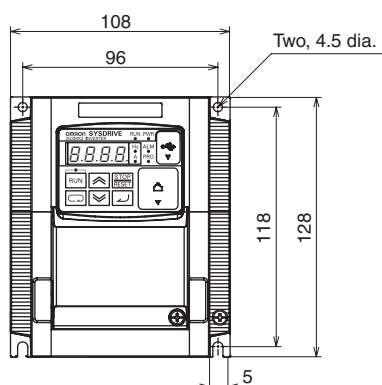

Power supply	Model	W [mm]	H [mm]	D [mm]	D1 [mm]
1-phase 200 V	3G3MX2-AB007	108	128	170.5	55
	3G3MX2-AB015				
	3G3MX2-AB022				
3-phase 200 V	3G3MX2-A2015	108	128	143.5	28
	3G3MX2-A2022				
3-phase 400 V	3G3MX2-A4004	108	128	170.5	55
	3G3MX2-A4007				
	3G3MX2-A4015				
	3G3MX2-A4022				
	3G3MX2-A4030				

3G3MX2-A2037  
3G3MX2-A4040

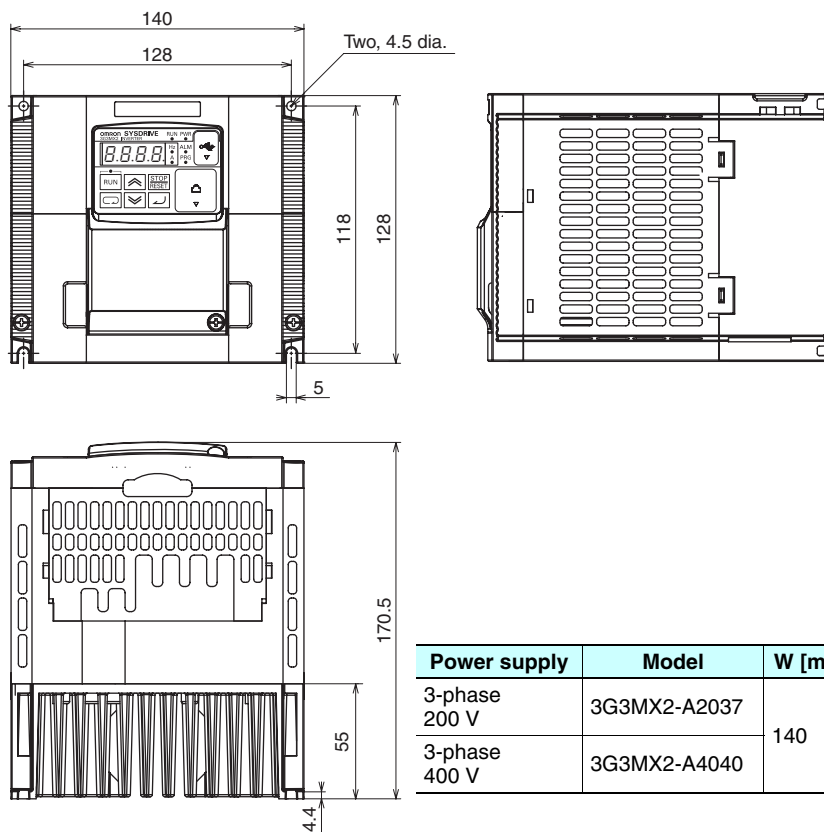

3G3MX2-A2055  
3G3MX2-A2075  
3G3MX2-A4055  
3G3MX2-A4075

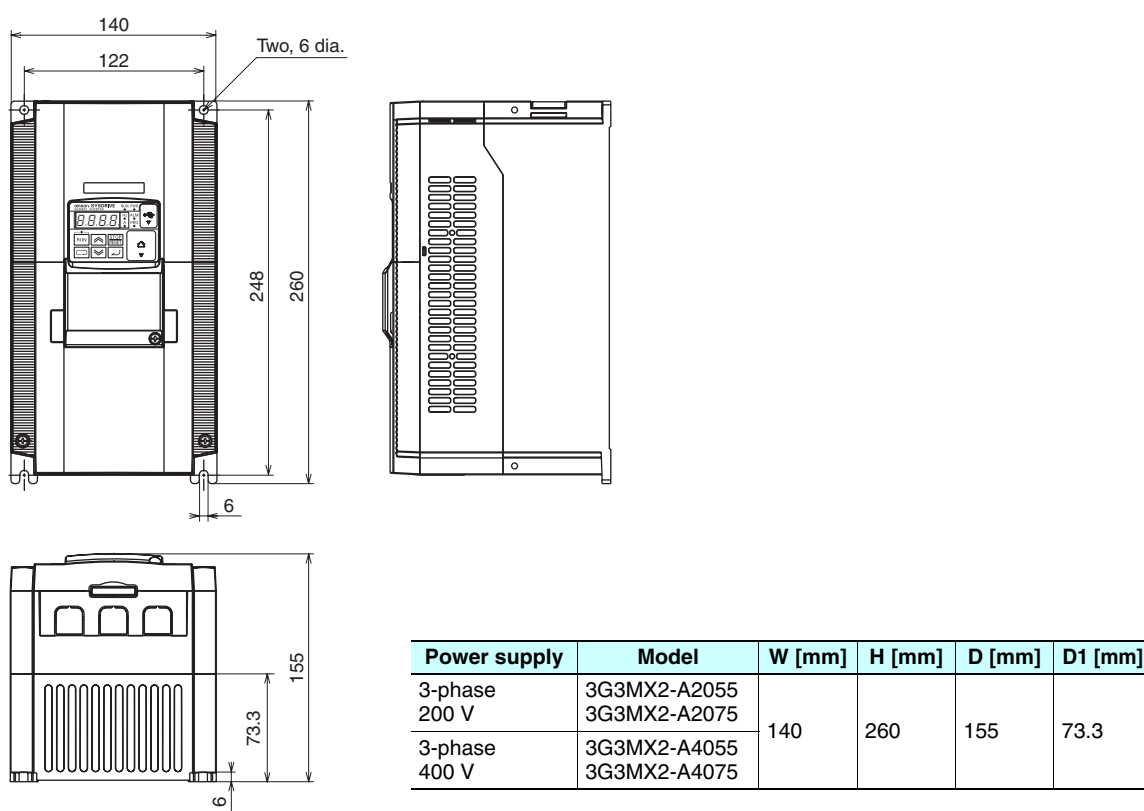

# 3G3MX2

3G3MX2-A2110  
3G3MX2-A4110  
3G3MX2-A4150

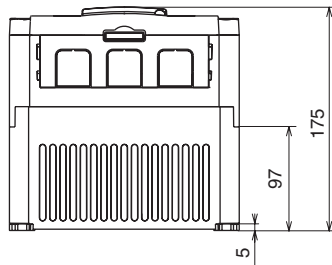
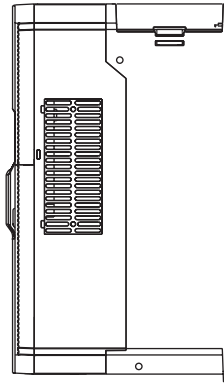
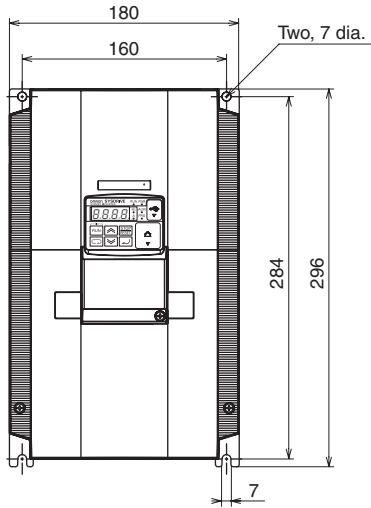

Power supply	Model	W [mm]	H [mm]	D [mm]	D1 [mm]
3-phase 200 V	3G3MX2-A2110	180	296	175	97
3-phase 400 V	3G3MX2-A4110 3G3MX2-A4150				

3G3MX2-A2150

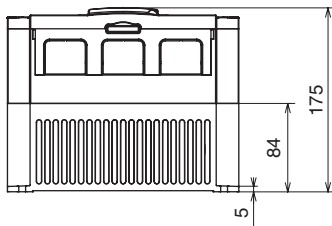
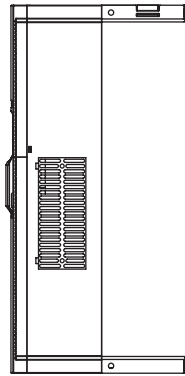
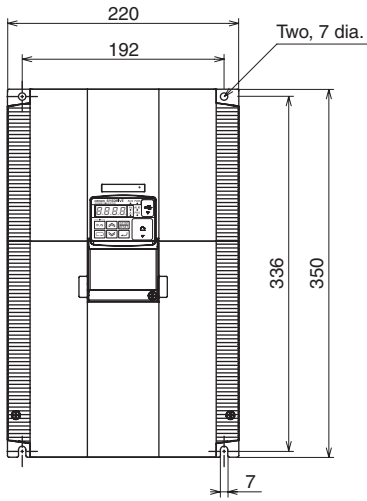

Power supply	Model	W [mm]	H [mm]	D [mm]	D1 [mm]
3-phase 200 V	3G3MX2-A2150	220	350	175	84

## 3G3MX2 Related Options

Name	Specifications		Model
Regenerative Braking Units	3-phase 200 VAC	General purpose with Braking resistor	3G3AX-RBU21
		High Regeneration purpose with Braking resistor	3G3AX-RBU22
	3-phase 400 VAC	General purpose with Braking resistor	3G3AX-RBU41
Braking Resistor	Compact type	Resistor 120 W, 180 $\Omega$	3G3AX-RBA1201
		Resistor 120 W, 100 $\Omega$	3G3AX-RBA1202
		Resistor 120 W, 5 $\Omega$	3G3AX-RBA1203
		Resistor 120 W, 35 $\Omega$	3G3AX-RBA1204
	Standard type	Resistor 200 W, 180 $\Omega$	3G3AX-RBB2001
		Resistor 200 W, 100 $\Omega$	3G3AX-RBB2002
		Resistor 300 W, 50 $\Omega$	3G3AX-RBB3001
		Resistor 400 W, 35 $\Omega$	3G3AX-RBB4001
	Medium capacity type	Resistor 400 W, 50 $\Omega$	3G3AX-RBC4001
		Resistor 600 W, 35 $\Omega$	3G3AX-RBC6001
		Resistor 1200 W, 17 $\Omega$	3G3AX-RBC12001

Name	Specifications of Inverter			Model
	Voltage class	CT: Heavy load	VT: Light load	
DC Reactor	3-phase 200 VAC	0.1 kW	0.2 kW	3G3AX-DL2002
		0.2 kW	0.4 kW	3G3AX-DL2004
		0.4 kW	0.75 kW	3G3AX-DL2007
		0.75 kW	1.1 kW	3G3AX-DL2015
		1.5 kW	2.2 kW	3G3AX-DL2022
		2.2 kW	3.0 kW	3G3AX-DL2037
		3.7 kW	5.5 kW	3G3AX-DL2055
		5.5 kW	7.5 kW	3G3AX-DL2075
		7.5 kW	11 kW	3G3AX-DL2110
		11 kW	15 kW	3G3AX-DL2150
	1-phase 200 VAC	15 kW	18.5 kW	3G3AX-DL2220
		0.1 kW	0.2 kW	3G3AX-DL2002
		0.2 kW	0.4 kW	3G3AX-DL2004
		0.4 kW	0.55 kW	3G3AX-DL2007
		0.75 kW	1.1 kW	3G3AX-DL2015
		1.5 kW	2.2 kW	3G3AX-DL2022
	3-phase 400 VAC	2.2 kW	3.0 kW	3G3AX-DL2037
		0.4 kW	0.75 kW	3G3AX-DL4007
		0.75 kW	1.5 kW	3G3AX-DL4015 *
		1.5 kW	2.2 kW	3G3AX-DL4022
		2.2 kW	3.0 kW	3G3AX-DL4037
		3.0 kW	4.0 kW	3G3AX-DL4037
		4.0 kW	5.5 kW	3G3AX-DL4055
		5.5 kW	7.5 kW	3G3AX-DL4075 *
		7.5 kW	11 kW	3G3AX-DL4110 *
		11 kW	15 kW	3G3AX-DL4150
		15 kW	18.5 kW	3G3AX-DL4220

Name	Specifications of Inverter			Model	
	Voltage class	CT: Heavy load	VT: Light load		
Radio Noise Filter	3-phase 200 VAC	0.1 kW	0.2 kW	3G3AX-ZCL2	
		0.2 kW	0.4 kW	3G3AX-ZCL2	
		0.4 kW	0.75 kW	3G3AX-ZCL2	
		0.75 kW	1.1 kW	3G3AX-ZCL2	
		1.5 kW	2.2 kW	3G3AX-ZCL2	
		2.2 kW	3.0 kW	3G3AX-ZCL2	
		3.7 kW	5.5 kW	3G3AX-ZCL1	
		5.5 kW	7.5 kW	3G3AX-ZCL1	
		7.5 kW	11 kW	3G3AX-ZCL1	
		11 kW	15 kW	3G3AX-ZCL1	
	15 kW	18.5 kW	3G3AX-ZCL1		
	1-phase 200 VAC	0.1 kW	0.2 kW	3G3AX-ZCL2	
		0.2 kW	0.4 kW	3G3AX-ZCL2	
		0.4 kW	0.55 kW	3G3AX-ZCL2	
		0.75 kW	1.1 kW	3G3AX-ZCL2	
		1.5 kW	2.2 kW	3G3AX-ZCL2	
		2.2 kW	3.0 kW	3G3AX-ZCL2	
	3-phase 400 VAC	0.4 kW	0.75 kW	3G3AX-ZCL1 (3G3AX-ZCL2)	
		0.75 kW	1.5 kW	3G3AX-ZCL1 (3G3AX-ZCL2)	
		1.5 kW	2.2 kW	3G3AX-ZCL1 (3G3AX-ZCL2)	
		2.2 kW	3.0 kW	3G3AX-ZCL1 (3G3AX-ZCL2)	
		3.0 kW	4.0 kW	3G3AX-ZCL1 (3G3AX-ZCL2)	
		4.0 kW	5.5 kW	3G3AX-ZCL1 (3G3AX-ZCL2)	
		5.5 kW	7.5 kW	3G3AX-ZCL1 (3G3AX-ZCL2)	
		7.5 kW	11 kW	3G3AX-ZCL1	
		11 kW	15 kW	3G3AX-ZCL1	
		15 kW	18.5 kW	3G3AX-ZCL1	
	Input Noise Filter	3-phase 200 VAC	0.1 kW	0.2 kW	3G3AX-NFI21
			0.2 kW	0.4 kW	3G3AX-NFI21
			0.4 kW	0.75 kW	3G3AX-NFI21
0.75 kW			1.1 kW	3G3AX-NFI22	
1.5 kW			2.2 kW	3G3AX-NFI23	
2.2 kW			3.0 kW	3G3AX-NFI23	
3.7 kW			5.5 kW	3G3AX-NFI24	
5.5 kW			7.5 kW	3G3AX-NFI25	
7.5 kW			11 kW	3G3AX-NFI26	
11 kW			15 kW	3G3AX-NFI27	
15 kW		18.5 kW	3G3AX-NFI28		
1-phase 200 VAC		0.1 kW	0.2 kW	3G3AX-NFI21	
		0.2 kW	0.4 kW	3G3AX-NFI21	
		0.4 kW	0.55 kW	3G3AX-NFI22	
		0.75 kW	1.1 kW	3G3AX-NFI23	
		1.5 kW	2.2 kW	3G3AX-NFI23 *	
		2.2 kW	3.0 kW	3G3AX-NFI24	

Name	Specifications of Inverter			Model
	Voltage class	CT: Heavy load	VT: Light load	
Input Noise Filter	3-phase 400 VAC	0.4 kW	0.75 kW	3G3AX-NFI41
		0.75 kW	1.5 kW	3G3AX-NFI41
		1.5 kW	2.2 kW	3G3AX-NFI41
		2.2 kW	3.0 kW	3G3AX-NFI42
		3.0 kW	4.0 kW	3G3AX-NFI42
		4.0 kW	5.5 kW	3G3AX-NFI43
		5.5 kW	7.5 kW	3G3AX-NFI43
		7.5 kW	11 kW	3G3AX-NFI44
		11 kW	15 kW	3G3AX-NFI45
		15 kW	18.5 kW	3G3AX-NFI46
EMC-compatible Noise Filter	3-phase 200 VAC	0.1 kW	0.2 kW	Under Development
		0.2 kW	0.4 kW	
		0.4 kW	0.75 kW	
		0.75 kW	1.1 kW	
		1.5 kW	2.2 kW	
		2.2 kW	3.0 kW	
		3.7 kW	5.5 kW	
		5.5 kW	7.5 kW	
		7.5 kW	11 kW	
		11 kW	15 kW	
		15 kW	18.5 kW	
	1-phase 200 VAC	0.1 kW	0.2 kW	
		0.2 kW	0.4 kW	
		0.4 kW	0.55 kW	
		0.75 kW	1.1 kW	
		1.5 kW	2.2 kW	
		2.2 kW	3.0 kW	
	3-phase 400 VAC	0.4 kW	0.75 kW	
		0.75 kW	1.5 kW	
		1.5 kW	2.2 kW	
		2.2 kW	3.0 kW	
		3.0 kW	4.0 kW	
		4.0 kW	5.5 kW	
		5.5 kW	7.5 kW	
		7.5 kW	11 kW	
	11 kW	15 kW		
	15 kW	18.5 kW		
Output Noise Filter	3-phase 200 VAC	0.1 kW	0.2 kW	3G3AX-NFO01
		0.2 kW	0.4 kW	3G3AX-NFO01
		0.4 kW	0.75 kW	3G3AX-NFO01
		0.75 kW	1.1 kW	3G3AX-NFO02
		1.5 kW	2.2 kW	3G3AX-NFO02
		2.2 kW	3.0 kW	3G3AX-NFO03
		3.7 kW	5.5 kW	3G3AX-NFO03
		5.5 kW	7.5 kW	3G3AX-NFO04
		7.5 kW	11 kW	3G3AX-NFO04
		11 kW	15 kW	3G3AX-NFO05
		15 kW	18.5 kW	3G3AX-NFO06
	1-phase 200 VAC	0.1 kW	0.2 kW	3G3AX-NFO01
		0.2 kW	0.4 kW	3G3AX-NFO01
		0.4 kW	0.55 kW	3G3AX-NFO02
		0.75 kW	1.1 kW	3G3AX-NFO02
		1.5 kW	2.2 kW	3G3AX-NFO03
		2.2 kW	3.0 kW	3G3AX-NFO03

Name	Specifications of Inverter			Model
	Voltage class	CT: Heavy load	VT: Light load	
Output Noise Filter	3-phase 400 VAC	0.4 kW	0.75 kW	3G3AX-NFO01
		0.75 kW	1.5 kW	3G3AX-NFO01
		1.5 kW	2.2 kW	3G3AX-NFO02
		2.2 kW	3.0 kW	3G3AX-NFO02
		3.0 kW	4.0 kW	3G3AX-NFO02
		4.0 kW	5.5 kW	3G3AX-NFO03
		5.5 kW	7.5 kW	3G3AX-NFO03
		7.5 kW	11 kW	3G3AX-NFO03
		11 kW	15 kW	3G3AX-NFO04
		15 kW	18.5 kW	3G3AX-NFO04
AC Reactor	3-phase 200 VAC	0.1 kW	0.2 kW	3G3AX-AL2025
		0.2 kW	0.4 kW	3G3AX-AL2025
		0.4 kW	0.75 kW	3G3AX-AL2025
		0.75 kW	1.1 kW	3G3AX-AL2025
		1.5 kW	2.2 kW	3G3AX-AL2055
		2.2 kW	3.0 kW	3G3AX-AL2055
		3.7 kW	5.5 kW	3G3AX-AL2110
		5.5 kW	7.5 kW	3G3AX-AL2110 *
		7.5 kW	11 kW	3G3AX-AL2220
		11 kW	15 kW	3G3AX-AL2220 *
	15 kW	18.5 kW	3G3AX-AL2330	
	1-phase 200 VAC	0.1 kW	0.2 kW	3G3AX-AL2025
		0.2 kW	0.4 kW	3G3AX-AL2025
		0.4 kW	0.55 kW	3G3AX-AL2025
		0.75 kW	1.1 kW	3G3AX-AL2055
		1.5 kW	2.2 kW	3G3AX-AL2055 *
		2.2 kW	3.0 kW	3G3AX-AL2110
	3-phase 400 VAC	0.4 kW	0.75 kW	3G3AX-AL4025
		0.75 kW	1.5 kW	3G3AX-AL4025
		1.5 kW	2.2 kW	3G3AX-AL4055
		2.2 kW	3.0 kW	3G3AX-AL4055
		3.0 kW	4.0 kW	3G3AX-AL4055
		4.0 kW	5.5 kW	3G3AX-AL4110
		5.5 kW	7.5 kW	3G3AX-AL4110 *
		7.5 kW	11 kW	3G3AX-AL4220
		11 kW	15 kW	3G3AX-AL4220 *
		15 kW	18.5 kW	3G3AX-AL4330
	Digital Operator			3G3AX-OP01

**Note:** When using the Inverter for light load rating, select the model with one size larger capacity (rated current).

\* Only the CT rating is supported.

## Related Manuals

Man No.	Model	Category
I570	3G3MX2	USERS MANUAL
W453	CXONE-ALL□□C/D-V□ WS02-DRVC01	OPERATION MANUAL

## Read and Understand this Catalog

Please read and understand this catalog before purchasing the product. Please consult your OMRON representative if you have any questions or comments.

## Warranty and Limitations of Liability

### WARRANTY

OMRON's exclusive warranty is that the products are free from defects in materials and workmanship for a period of one year (or other period if specified) from date of sale by OMRON.

OMRON MAKES NO WARRANTY OR REPRESENTATION, EXPRESS OR IMPLIED, REGARDING NON-INFRINGEMENT, MERCHANTABILITY, OR FITNESS FOR PARTICULAR PURPOSE OF THE PRODUCTS. ANY BUYER OR USER ACKNOWLEDGES THAT THE BUYER OR USER ALONE HAS DETERMINED THAT THE PRODUCTS WILL SUITABLY MEET THE REQUIREMENTS OF THEIR INTENDED USE. OMRON DISCLAIMS ALL OTHER WARRANTIES, EXPRESS OR IMPLIED.

### LIMITATIONS OF LIABILITY

OMRON SHALL NOT BE RESPONSIBLE FOR SPECIAL, INDIRECT, OR CONSEQUENTIAL DAMAGES, LOSS OF PROFITS, OR COMMERCIAL LOSS IN ANY WAY CONNECTED WITH THE PRODUCTS, WHETHER SUCH CLAIM IS BASED ON CONTRACT, WARRANTY, NEGLIGENCE, OR STRICT LIABILITY.

In no event shall the responsibility of OMRON for any act exceed the individual price of the product on which liability is asserted.

IN NO EVENT SHALL OMRON BE RESPONSIBLE FOR WARRANTY, REPAIR, OR OTHER CLAIMS REGARDING THE PRODUCTS UNLESS OMRON'S ANALYSIS CONFIRMS THAT THE PRODUCTS WERE PROPERLY HANDLED, STORED, INSTALLED, AND MAINTAINED AND NOT SUBJECT TO CONTAMINATION, ABUSE, MISUSE, OR INAPPROPRIATE MODIFICATION OR REPAIR.

## Application Considerations

### SUITABILITY FOR USE

OMRON shall not be responsible for conformity with any standards, codes, or regulations that apply to the combination of products in the customer's application or use of the products.

Take all necessary steps to determine the suitability of the product for the systems, machines, and equipment with which it will be used.

Know and observe all prohibitions of use applicable to this product.

NEVER USE THE PRODUCTS FOR AN APPLICATION INVOLVING SERIOUS RISK TO LIFE OR PROPERTY WITHOUT ENSURING THAT THE SYSTEM AS A WHOLE HAS BEEN DESIGNED TO ADDRESS THE RISKS, AND THAT THE OMRON PRODUCTS ARE PROPERLY RATED AND INSTALLED FOR THE INTENDED USE WITHIN THE OVERALL EQUIPMENT OR SYSTEM.

### PROGRAMMABLE PRODUCTS

OMRON shall not be responsible for the user's programming of a programmable product, or any consequence thereof.

## Disclaimers

### CHANGE IN SPECIFICATIONS

Product specifications and accessories may be changed at any time based on improvements and other reasons.

It is our practice to change model numbers when published ratings or features are changed, or when significant construction changes are made. However, some specifications of the products may be changed without any notice. When in doubt, special model numbers may be assigned to fix or establish key specifications for your application on your request. Please consult with your OMRON representative at any time to confirm actual specifications of purchased products.

### DIMENSIONS AND WEIGHTS

Dimensions and weights are nominal and are not to be used for manufacturing purposes, even when tolerances are shown.

### PERFORMANCE DATA

Performance data given in this catalog is provided as a guide for the user in determining suitability and does not constitute a warranty. It may represent the result of OMRON's test conditions, and the users must correlate it to actual application requirements. Actual performance is subject to the OMRON Warranty and Limitations of Liability.

**OMRON Corporation**  
**Industrial Automation Company**  
**Control Devices Division H.Q.**  
**Automation & Drive Division**  
**Drive Department 1**

Shiokoji Horikawa, Shimogyo-ku,  
Kyoto, 600-8530 Japan  
Tel: (81) 75-344-7173/Fax: (81) 75-344-7149

**Regional Headquarters**

**OMRON EUROPE B.V.**  
Wegalaan 67-69-2132 JD Hoofddorp  
The Netherlands  
Tel: (31)2356-81-300/Fax: (31)2356-81-388  
OMRON Industrial Automation Global: [www.ia.omron.com](http://www.ia.omron.com)

**OMRON ELECTRONICS LLC**  
One Commerce Drive Schaumburg,  
IL 60173-5302 U.S.A.  
Tel: (1) 847-843-7900/Fax: (1) 847-843-7787

**OMRON ASIA PACIFIC PTE. LTD.**  
No. 438A Alexandra Road # 05-05/08 (Lobby 2),  
Alexandra Technopark, Singapore 119967  
Tel: (65) 6835-3011/Fax: (65) 6835-2711

**OMRON (CHINA) CO., LTD.**  
Room 2211, Bank of China Tower,  
200 Yin Cheng Zhong Road,  
PuDong New Area, Shanghai, 200120, China  
Tel: (86) 21-5037-2222/Fax: (86) 21-5037-2200

**Authorized Distributor:**

© OMRON Corporation 2009 All Rights Reserved.  
In the interest of product improvement,  
specifications are subject to change without notice.

**Cat. No. I916-E1-01**

Printed in Japan  
0909 (0909)