



# BONFIGLIOLI VECTRON

## SYNTHESIS

### Operations Manual

single phase 115 V 0.2 - 0.75 kW  
single phase 230 V 0.2 - 2.2 kW  
three phase 400 V 0.75 - 2.2 kW



 **BONFIGLIOLI**

*Power & Control Solutions*



# Operations Manual

## Table of Contents

Foreword.....	1
Examination before installation.....	2
<b>Chapter 1 Safety Precautions</b>	
1. Precautions for Operation.....	3
2. Environmental Precautions.....	6
<b>Chapter 2 Hardware Instruction and Installation</b>	
1. Operational Environment.....	7
2. Sample Model No. Identification.....	8
3. Specifications.....	9
4. Wiring diagram.....	15
5. Dimensions & Location of terminal block.....	19
<b>Chapter 3 Software Index</b>	
1. Keypad Operating Instructions .....	29
2. Parameters List.....	30
3. Parameter Function Description .....	31
4. Malfunction Indication and Countermeasure .....	43
5. General Malfunction Examination Method.....	46
<b>Chapter 4 Maintenance and Examination</b>	
1. Maintenance and Examination.....	48
<b>Chapter 5 Option and accessories</b>	
1. Class B Emi filter.....	50
2. Braking resistors .....	51

## 1. Foreword

To fully employ all functions of this AC Drive, and to ensure the safety for its users, please read through this operations manual in detail. Should you have any further questions, please feel free to contact your local distributor or regional representative.

### ⌘ Please use Precaution with this product

The AC Drive is a power electronic device. For safety reasons, please read carefully those paragraphs with “WARNING” or “CAUTION” symbols. They are important safety precautions to be aware of while transporting, installation, operating or examining the AC drive. Please follow these precautions to ensure your safety.

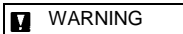

Personnel injury may be resulted by improper operation.

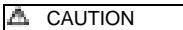

The AC Drive or mechanical system may be damaged by improper operation.

 <b>WARNING</b>
<ul style="list-style-type: none"> <li>● Do not touch the PCB or components on the PCB right after turning off the power before the charging indicator went off.</li> <li>● Do not attempt to wire circuitry while power is on. Do not attempt to examine the components and signals on the PCB while the inverter operating.</li> <li>● Do not attempt to disassemble or modify internal circuitry, wiring, or components of the inverter.</li> <li>● The grounding terminal of the inverter must be grounded properly with 200V class type III standard.</li> <li>● This is a product of the restricted sales distribution class according to EN61800-3. In a domestic environment this product may cause radio interference in which case the user may be required to take adequate measures.</li> </ul>

 <b>CAUTION</b>
<ul style="list-style-type: none"> <li>● Do not attempt to perform dielectric strength test to internal components of the inverter. There are sensitive semiconductor-devices vulnerable to high voltage in the inverter.</li> <li>● Do not connect the output terminals: T1 (U), T2 (V), and T3 (W) to AC power input</li> <li>● The CMOS IC on the primary PCB of the inverter is vulnerable to static electrical charges. Do not contact the primary PCB of the inverter.</li> </ul>

## **2. Examination before installation**

Every inverter has been fully tested and examined before shipment. Please carry out the following examination procedures after unpacking your AC inverter.

- Check to see if the model number of the AC inverter matches the model number of the AC inverter that you ordered.
- Check to see whether any damage occurred to the AC inverter during shipment. Do not connect the AC inverter to the power supply if there is any sign of damage.

Report this to a regional sale representative if you find any abnormal condition as mentioned above.

## Chapter 1: Safety Precaution

### 1. Precautions for operation

#### Before turning ON power

 CAUTION

Choose the appropriate power source with correct voltage settings for the input voltage specification of the AC inverter.

 WARNING

Special care must be taken while wiring the primary circuitry panel. The L1 and L2 terminal must be connected to the input power source and must not be mistakenly connected to T1, T2 or T3 out put terminals. This may damage the inverter when the power is turned on.

 CAUTION

- Do not attempt to transport the inverter by the front of the cover. Securely hold the inverter by the heat-sink mounting chassis to prevent the inverter from falling, this may cause personnel injury or damage to the inverter itself.
- Install the inverter onto a firm metal base plate or another non-flammable type material. Do not install the inverter onto or nearby any flammable material.
- An additional cooling fan may need to be installed if several inverters are installed into one control panel. The inside temperature inside an enclosed panel should be below 40 degrees to avoid overheating.
- Turn off the power supply before proceeding to remove or perform any work on any panel. Carry out installation procedures according to instructions given in order to avoid a situation resulting in an operational malfunction.
- Suitable for use on a circuit capable of delivering not more than 5000 RMS symmetrical amperes. 240 Volts maximum.
- This product is not provided with over speed protection.
- Only intended for use in a pollution degree 2 macro environment or equivalent

## When power is applied

**!** WARNING

- Do not attempt to install or remove input or out put connectors of inverter when the power supply is turned on. Otherwise, the inverter may be damaged due to the surge peak caused by the insertion or removal of power.
- When momentary power loss is longer than 2 seconds (the large of horse power, the longer of time), the inverter does not have enough storage power to control the circuit; Therefore, when power is regenerated, the operation of the inverter is based on the setup of F\_10 and the condition of external switch, this is considered to be 「restart」 in the following paragraphs.
- When the momentary power loss is short, the inverter still has enough storage power to control the circuit; therefore, when power is regenerated, the inverter will automatically start operation again depends on the setup of F\_23.  
When restart the inverter, the operation of the inverter is based on the setup of F\_10 and the condition of external switch (FWD/REV button). Attention: the restart operation is irrelevant with F\_23/F\_24.
  - (1) When F\_10=0, the inverter will not start after restart.
  - (2) When F\_10=1 and the external switch (FWD/REV button) is OFF, the inverter will not start after restart.
  - (3) When F\_10=1 and the external switch (FWD/REV button) is ON, the inverter will start automatically after restart. Attention: Base on safety reason, please turn off the external switch (FWD/REV button) after power loss to avoid possible damage to the machine and the human body after sudden regeneration of power.

## Under Operation

 WARNING

Do not use a separate device to switch ON or OFF motor during operation. Otherwise, the inverter may experience an over-current breakdown.

 WARNING

- Do not remove the front cover of the inverter when the power is ON to avoid personnel injury caused by electrical shock.
- When the automatic restart function is enabled, the motor and machinery will be restarted automatically.

 CAUTION

- Do not touch the heat-sink base during operation.
- The inverter can be easily operated from a low-speed to high-speed range. Please reconfirm the operating range of motor and the machinery you are controlling.
- Do not examine the signals on the PCB of the inverter when it is under operation.
- All inverters are properly adjusted and set before delivery.

 CAUTION

Do not proceed with disassembly or examination procedure before ensuring that the power is off and the Power LED extinguished.

## When performing an examination or maintenance

 CAUTION

Inverter environment should be within temp:  $-10\text{ }^{\circ}\text{C} \sim +40\text{ }^{\circ}\text{C}$ , humidity under 95% RH without condensing.

 CAUTION

After the removal of shield sticker, the environment temperature should be within  $-10\text{ }^{\circ}\text{C} \sim +50\text{ }^{\circ}\text{C}$  and humidity under 95% RH without condensing. Besides, the inverter should be free from water dripping or metal dust.

## 2. Precautions of operation environment

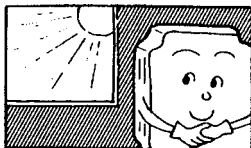

Avoid any direct sunlight

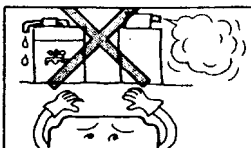

Keep away from corrosive gas or liquid

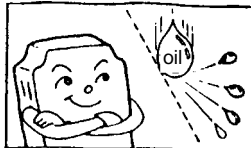

Keep away from oil grease and gas

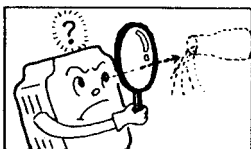

Keep away from salty environments



Keep away from rain or where dripping water may get into the inverter

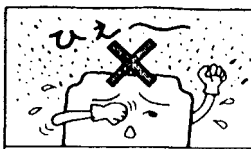

Avoid metal dust and dusty environments

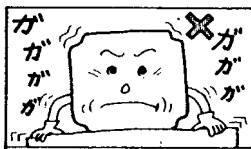

Avoid massive vibration



Avoid excessive direct heat

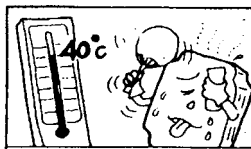

Avoid where environmental temperatures are too high

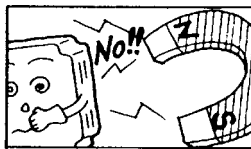

Keep away from high electrical-magnetic waves or

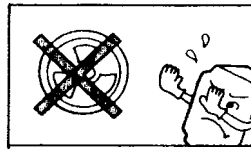

Keep away from radioactive matter

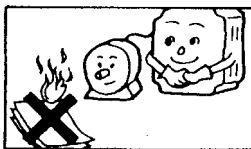

Keep away from flammable material

## Chapter 2: Hardware Instructions and Installation

### 1. Operational Environment

The installation site of the inverter is very important. It relates directly to the functionality and the life span of your inverter. Please carefully choose the installation site to meet the following requirements:

- Mount the unit vertically
- Environment temperature:  $-10^{\circ}\text{C} \div +40^{\circ}\text{C}$  (with cover removed:  $-10^{\circ}\text{C} \div +50^{\circ}\text{C}$ )
- Avoid placing close to any heating equipment
- Avoid water dripping or humid environment
- Avoid direct sunlight
- Avoid oil or salty corrosive gas
- Avoid contacting corrosive liquid or gas
- Prevent foreign dusts, flocks, or metal scraps from entering interior
- Avoid electric-magnetic interference (soldering or power machinery)
- Avoid vibration, if vibration cannot be avoided, an anti-rattle mounting device should be installed to reduce vibration.
- If the inverter is installed in an enclosed control panel, please remove the shield sticker located at the top of the inverter. This will allow additional airflow and cooling.

External Fan Placement needs to be over the top of the inverter

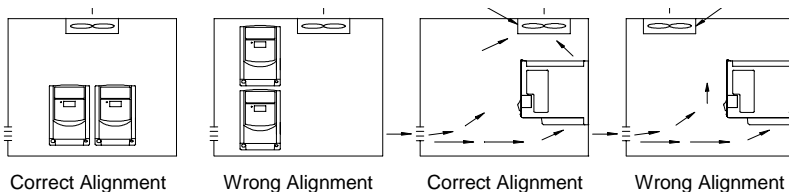

- For proper Installation of the inverter you must place the front side of the inverter facing front and the top of the inverter in the up direction for better heat dissipation.
- Installation must be compliant to the following requirements.

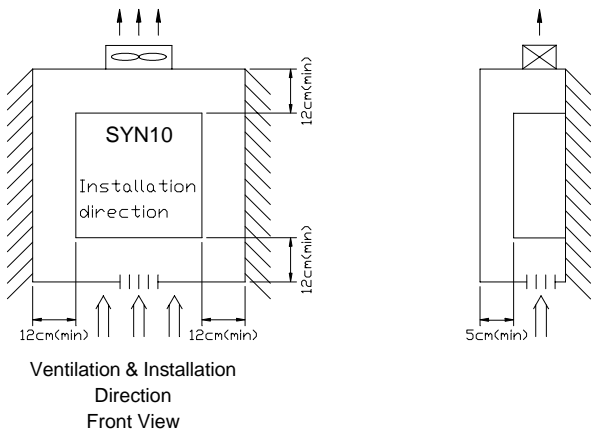

Note: Maximum temperature in the enclosure 50 °C

## 2. Sample Model No. Identification

**SYN10 S 220 05 AF - -**

Series \_\_\_\_\_

Input phases	—	S = single phase, T = three phases
Input voltage	—	115, 230, 400V
Size/Power	—	01 = 0.2kW    03 = 0.4kW    05 = 0.75kW 07 = 1.5kW    09 = 2.2kW
Filter	—	__ = no EMI filter, AF = class "A" EMI filter
Degree of protection	—	__ = IP20, IP65 = IP65
Switch (only for IP65)	—	__ = no switch, S = integrated switch

### 3. Specification:

#### Basic specification:

<b>Model: SYN10</b>		<b>S 115 01</b>	<b>S 115 03</b>	<b>S 115 05</b>
Suitable Motor Power Rating (KW)		0.2	0.4	0.75
<b>Rated</b>	Motor (HP)	1/4	1/2	1
	Output Current (A)	1.4	2.3	4.2
	Capacity (KVA)	0.53	0.88	1.6
	Weight (Kg )	0.7	0.72	0.8
Input Voltage Max.		Single phase 100-120V (+10%, -15%), 50 / 60Hz (+/-5%)		
Output Voltage Max.		Three phase 200-240V (Proportional to input voltage)		
Dimension W*H*D (mm)		72*132*118		
EMC Specification		Without Filter		

<b>Model: SYN10</b>		<b>S 220 01 AF</b>	<b>S 220 03 AF</b>	<b>S 220 05 AF</b>	<b>S 220 07 AF</b>	<b>S 220 09 AF</b>
Suitable Motor Power Rating (KW)		0.2	0.4	0.75	1.5	2.2
<b>Rated</b>	Motor (HP)	0.25	0.5	1	2	3
	Output Current (A)	1.4	2.3	4.2	7.5	10.5
	Capacity (KVA)	0.53	0.88	1.6	2.9	4.0
	Weight (Kg)	0.76	0.77	0.8	1.66	1.76
Input Voltage Max.		Single phase 200-240V (+10%,-15%), 50 / 60 Hz (+/-5%)			Single/Three phase 200-240V 50 / 60 Hz	
Output Voltage Max.		Three phases 200-240V (Proportional to input voltage)				
Dimension W*H*D (mm)		72*132*118			118*143*172	
EMC Specification		Class A (Single Phase Filter built in)				

<b>Model: SYN10</b>		<b>T 400 05 AF</b>	<b>T 400 07 AF</b>	<b>T 400 09 AF</b>
Suitable Motor Power Rating (KW)		0.75	1.5	2.2
<b>Rated</b>	Motor (HP)	1	2	3
	Output Current (A)	2.3	3.8	5.2
	Capacity (KVA)	1.7	2.9	4.0
	Weight (Kg )	1.6	1.62	1.68
Input Voltage Max.		Three phase 380-460V (+10%, -15%), 50 / 60Hz (+/-5%)		
Output Voltage Max.		Three phase 380-460V (Proportional to input voltage)		
Dimension W*H*D (mm)		118*143*172		
EMC Specification		Class A (Three Phases Filter built in)		

## Functional specification:

Item		Specification
Input Signal Type		PNP type (SOURCE) input (External 24VDC Input is allowed)
Control Method		Sinusoidal wave PWM control
<b>Freq. Control</b>	Freq. Range	1~200 Hz
	Resolution Setting	Digital: 0.1 Hz (1 ~ 99.9 Hz); 1 Hz (100 ~ 200 Hz) Analog: 1Hz/ 60 Hz
	Keyboard Setting	Directly setup by ▲ and ▼ buttons.
	External Signal Setting	0~10V, 4 ~ 20mA, 0 ~ 20mA
	Other function	Frequency upper and lower limit
<b>General Control</b>	Carrier frequency	4~16KHz
	Accelerate/Decelerate time	0.1~ 999 Sec
	V/F Pattern	6 Patterns
	Torque control	Torque boost level adjustable (manual torque boost)
	Multi-Functional input	2 point, to be used as multi-speed 1(Sp.1) / multi-speed 2(Sp.2) / Jog / External quickstop / External bb / Reset
	Multi-Functional output	1a Relay terminal, to be setup as Fault / Running / Frequency.
	Braking Torque	S115, S220 01, 03 and 05: about 20% S220 07, 09 and T400: 20%~100% built-in braking transistor
Other function	Decelerate or free run stop, Auto reset, DC braking frequency / Voltage / Time can be setup by constants.	
Display		Three digital LED display frequency / inverter parameter / fault record / program version.
Operating temperature		-10°C ~ +40°C (with cover removed: -10°C ~ +50°C)
Humidity		0~95% RH non-condensing.
Vibration		Under 1 G (9.8 m/s <sup>2</sup> )
EMC specification		EN50081-1, EN50081-2, EN50082-2, EN50178, EN61800-3
UL		UL508C
<b>Protection Function</b>	Overload protection	150% for 1 min.
	Over-voltage	DC voltage > 410V(200 series); DC voltage > 800V(400 series)
	Under voltage	DC voltage < 200V(200 series); DC voltage < 400V(400 series)
	Momentary Power-loss	0 ~ 2 sec: the inverter can be restarted using speed search feature.
	Stall Prevention	During Acceleration / Deceleration/ Constant speed
	Output Short-circuit	Electronic circuitry protection
	Grounding fault	Electronic circuitry protection
	Other function	Heat sink overheat protection, Current limit
Installation		Mounting screw or DIN rail (Option).

## ■ Suitable optional and Wiring Specification

### Molded-Case Circuit Breaker / Magnetic Contact

- **Warranty does not apply to damage caused by the following situations:**

- (1) Damage to the inverter caused by the lack of appropriate molded-case circuit breaker or when a circuit breaker with too large of capacity is installed between the power supply and the inverter.
- (2) Damage to the inverter caused by the magnetic contact, phase advancing capacitor, or surge-protector installed between the inverter and the motor.

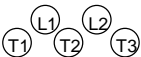
Model Type	SYN10 S 220 01/03 AF	SYN10 S 220 05/07 AF	SYN10 S 220 09 AF	SYN10 S 400 0 AF
Molded-case circuit breaker	15A	20A	30A	15A
Primary Circuit Terminal (TM1) 	Wire dimension (#14AWG) 2.0mm <sup>2</sup> Terminal screw M3	Wire dimension (#14AWG) 2.0m m <sup>2</sup> Terminal screw M3/M4	Wire dimension 3.5mm <sup>2</sup> Terminal screw M4	Wire dimension 3.5mm <sup>2</sup> Terminal screw M4
Signal Terminal (TM2) 1~11	Wire dimension 0.75mm <sup>2</sup> (#18 AWG), Terminal screw M3			

Use copper conductors only size field wiring based on 80 degrees C wire only.

- **Please utilize three-phase squirrel-cage induction motor with appropriate capacity.**
- **If the inverter is used to drive more than one motor, the total capacity must be smaller than the capacity of the inverter. Additional thermal overload relays must be installed in front of each motor. Use the Fn\_18 at 1.0 times of the rated value specified on the motor nameplate at 50Hz, 1.1 times of the rated value specified on the motor nameplate at 60Hz.**
- **Do not install phase advancing capacitors, LC, or RC component between the inverter and the motor.**

## Application and precautions of Peripherals

### From the Power Source:

- Apply the power source at the correct rated voltage to prevent from damaging the inverter.
- A Power Disconnect or Circuit breaker must be installed between the AC power supply and the inverter.

### Molded-case circuit breaker:

- Utilize an appropriate circuit breaker that's suitable for the rated voltage and current ratings of the inverter to switch ON/OFF the power supply to the inverter and as additional protection for the inverter.
- Do not operate the circuit breaker to switch ON or OFF the inverter. The circuit breaker should be used only to supply input power and should not be used for operational sequence.

### Leakage circuit breaker:

- An earth leakage circuit breaker should be added to prevent false operation cause by leakage current and to ensure personnel safety.

### Magnetic Contact:

- The Magnetic Contact can be omitted at ordinary operation. To utilize external control, automatic restart, or breaking controller the magnetic contact must be added at the primary side.
- Do not operate the magnetic contact to switch ON or OFF the inverter.

### Power improvement AC Reactor:

- If large capacity power source is applied (over 600KVA), additional AC reactor may be added to improve power factor.

### Inverter:

- Power supply input terminals L1 and L2 are not differentiated on phase sequence. They can be arbitrarily connected. Their connection may be interchanged.
- Output terminal T1, T2, and T3 should be connected to the U, V, and W terminals of the motor respectively. If motor turns in opposite direction of the inverter command, simply exchanging two of the three wire connections will correct this problem.
- Output terminal T1, T2, and T3 must not be connected to power source to prevent from damaging the inverter.
- Grounding terminal: properly ground the grounding terminal in compliance to 200V class type three grounding. (The 400V class type is special grounding.)

External wiring should be carried out in accordance with following requirement. Check and reassure the wiring is correct after the wiring is complete.

(Do not utilize the control circuitry buzzer to check the wiring).

## EMI connections:

It is very important that the connections between the inverter, the shielded motor cable, and the EMI filters are tested as follows.

- Use a metal grounding plate and place the frequency inverter and the EMI filter on the plate.
- Use a shielded motor cable with 4 connectors (U, V, W, & Earth), don't use the shielding as safety earth (shield is high frequency earth)
- Remove any paint around the two metal coupling nut holes. So that the metal coupling nuts (and the shielding) make contact with the frequency inverter and the motor.
- Don't solder a conductor to the shielding.
- Use a metal clamp to connect the shielding from the motor cable with the metal grounding plate.
- Now there is a perfect high frequency earth connection between frequency inverter, grounding plate and EMI filter.
- Keep the distance between the frequency inverter and EMI filter as short as possible (< 30cm) if longer use a shielded cable with a metal coupling nut and a metal clamp to connect the shielded cable to the frequency inverter and metal grounding plate.
- The only earth connection between the LISN and the test plate should be via the EMI filter.
- Use a motor which equals the power rating or below of the inverter rating.
- Install a noise filter for inverter onto the output side of the primary circuitry can suppress conducting noise.

## Class B:

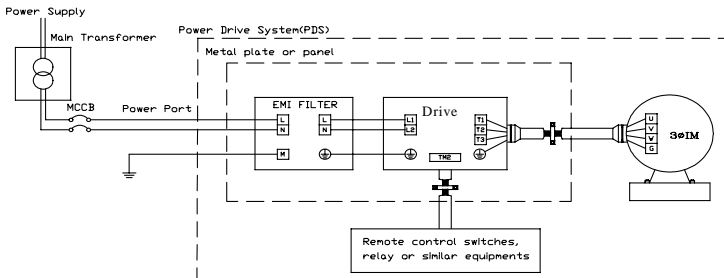

Class A:

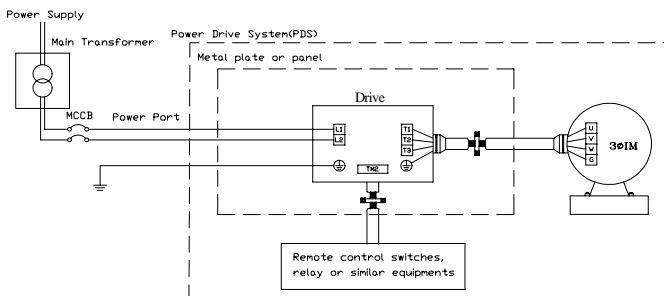

When the distance between the inverter and motor is longer than 100 meters, cable wire should be carefully chosen to reduce the wiring resistance below 3% and the voltage drop

$$(V) = \sqrt{3} \times \text{Wire resistance } (\Omega/\text{km}) \times \text{wire length (m)} \times \text{current} \times 10^{-3}$$

- (B) Control circuitry wiring must be separated terminated and away from the primary power circuitry and other high-voltage or large-current power lines to avoid noise interference.
- To reduce the noise interference and avoid possible operational problems, shielded twisted pair cable should be used to wire the control circuitry. Please refer to following diagram. Connect the shielding wire onto the grounding terminal. Only connect one end of the shield.

**Wiring distance must be under 50m.**

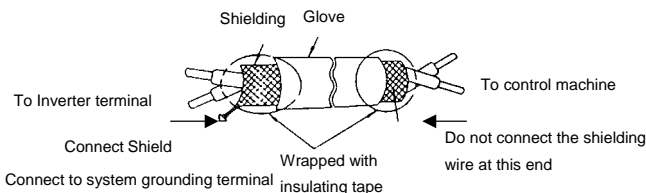

- (C) The grounding terminal of the inverter must be correctly grounded in compliance with 200V class type three grounding.
- Grounding wire should be wired in accordance to electrical equipment (AWG) with the length of the grounding wire as short as possible.

- The grounding wire of the inverter must not be grounded together with other large current loads (such as soldering machines or large current motors). They should be grounded separately.
- Grounding circuitry must not be formed when grounding several inverters together.

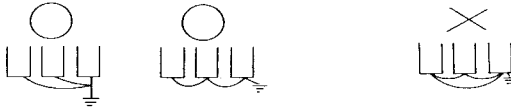

(a) good

(b) good

(c) not good

(D) Wire specification, apply appropriate wire with correct diameter for primary power circuitry and control circuitry in accordance with electricity regulations.

#### 4. Wiring Diagram

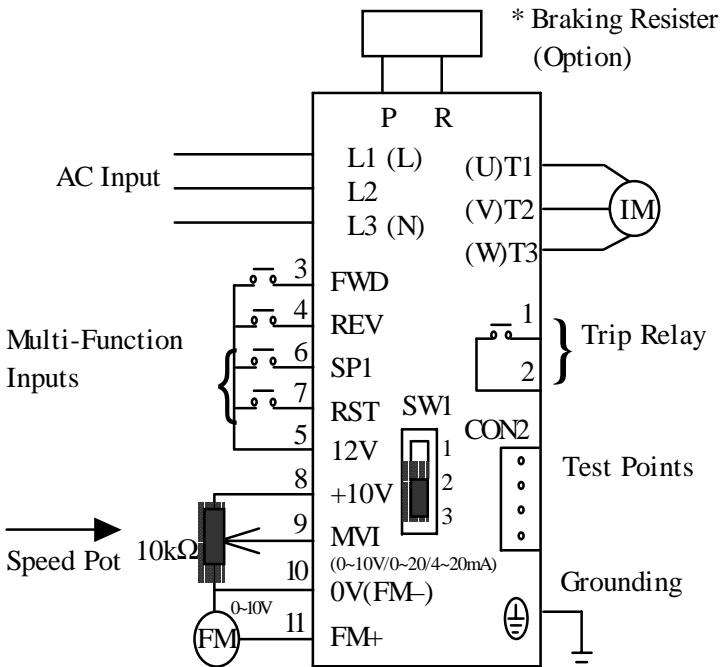

Wire Terminations to the Inverter must be made in compliance to the applicable standards.

**(External 24V supply)**

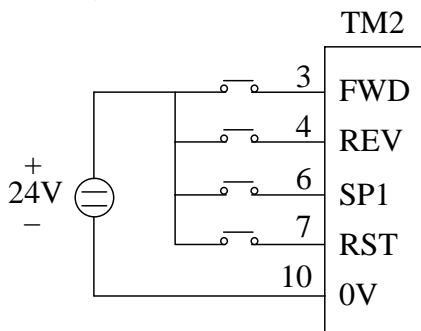

## Inverter terminal descriptions

### Primary Circuitry Terminal Block (TM1) descriptions

Terminal Symbol	Function Description
L1/L (R)	Primary power source input to Drive
L2 (S)	Single phase: L1/L2 or L/N
L3/N (T)	Three phase: L1/L2/L3
P	External braking resistor terminal
R	(Only for models SYN10 220 07 / 09 and T400 05 / 07 / 09)
T1 (U)	Inverter output to Motor
T2 (V)	
T3 (W)	

Tightening torque for TM1 is 1 Nm (in the S155 and S220 01 / 03 / 05 models).

Tightening torque for TM1 is 1.3 Nm (in the S220 07 / 09 and T400 05 / 07 / 09 models).

\* Wire voltage rating must be a minimum of 300V (200V series) and 600V (400V series)

### Control Circuitry Terminal Block (TM2) description

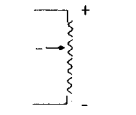
Terminal Symbol		Function Description	
1	TRIP	Fault relay output terminal Multi function output terminal (refer to F_21)	
2	RELAY	Connection point rated capacity 250VAC/1A (30VDC / 1A)	
3	FWD (FW)	Operation control terminals (refer to F_03)	
4	REV (RE)		
5	+ 12V(12)	Common point of terminal 3 / 4 / 6 / 7	
6	SP1(SP)	Multifunction input terminals (refer to F_19)	
7	RESET(RS)		
8		+10V	Power terminal for potentiometer ( Pin 3 )
9		Analog input wire Wiper	Analog frequency signal input terminal ( Pin 2 of potentiometer or positive terminal of 0~10V / 4~20mA / 0~20mA)
10		0V(FM -)	Analog common point
11	FM+	Analog output positive connection point	Analog frequency signal output terminal Output terminal signal is 0 ~ 10VDC/Fn6

Tightening torque for TM2 is 0.57 Nm.

\* Wire voltage rating must be a minimum of 300V

\* Control wiring should not run in the same conduit or raceway with power or motor wiring

\* Single Input and Output Terminals (TM2) Ratings are ALL Class 2

### SW1 function description

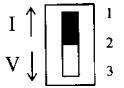
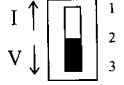
SWITCH 1	External signal type
	<p>0~20mA analog signal (When F_11 is set to 1)</p> <p>4~20mA analog signal (When F_11 is set to 2)</p>
	<p>0~10 VDC analog signal (When F_11 is set to 1) (default)</p>

## Control Circuitry Terminal Block Electrical Features

Terminal number	Terminal name	Default function	Electrical features	Parameter
1	Trip Relay	Relay output	250VAC/1A 30VDC/1A	F_21
2				
3	FWD	Forward run	12/24VDC, 4.5mA, 3.6K_	F_03
4	REV	Reverse run		F_10
5	DC12V	Output power supply +12VDC	12VDC, 20mA	-
6	SP1	Multifunction digital input	12/24VDC, 4.5mA, 3.6K_	F_19
7	RST			F_20
8	DC10V	Output power supply +10VDC	10VDC, 10mA	-
9	V / I in	Analog input (+) Voltage/Current (Potentiometer 10K_)	DC 0-10V 20K_ DC 0-20/4-20mA 250_ 10 bits resolution	F_06, F_07 F_11 Switch1
10	0V	Common Analog (-)	0V	-
11	FM +	Analog output (+)	DC 0-10V, 1mA	F_06 F_07

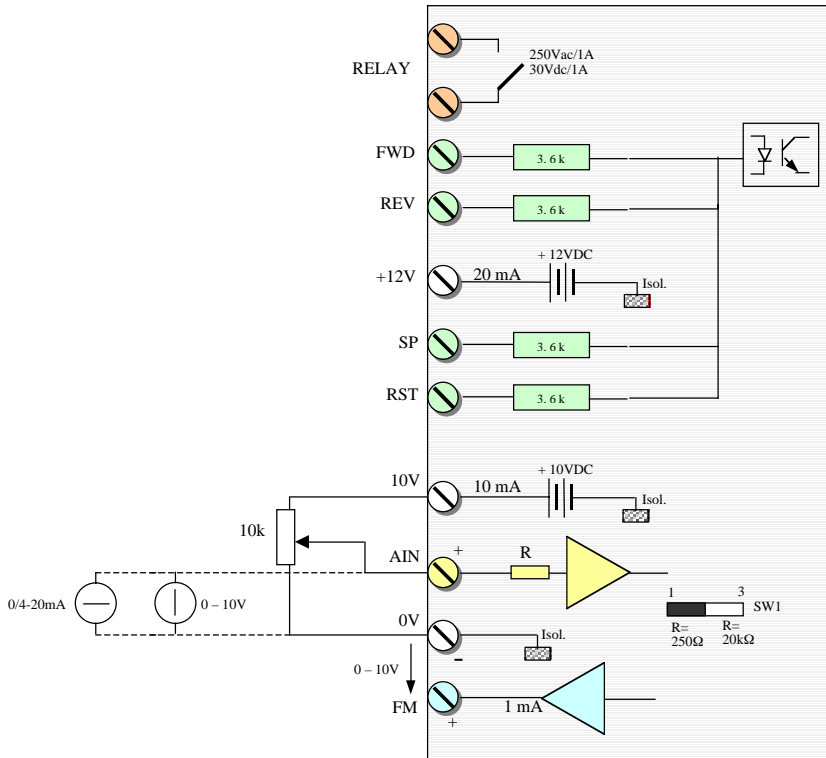

## 5. Dimensions & Location of terminal block

SYN10 S 115 01/03/05, S 220 01/03/05:

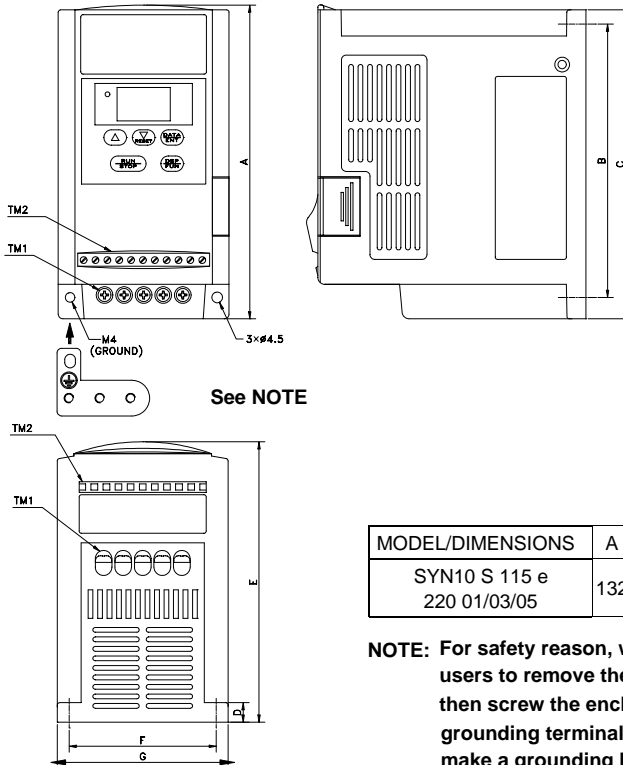

Unit: mm

MODEL/DIMENSIONS	A	B	C	D	E	F	G
SYN10 S 115 e 220 01/03/05	132	116	130	8.2	118	61	72

**NOTE:** For safety reason, we strongly recommend users to remove the M4 grounding screw then screw the enclosed "metal frame grounding terminal" on the same location to make a grounding bar to ensure good earth protection.

**SYN10 S 220 07/09**

**SYN10 T 400 05/07/09**

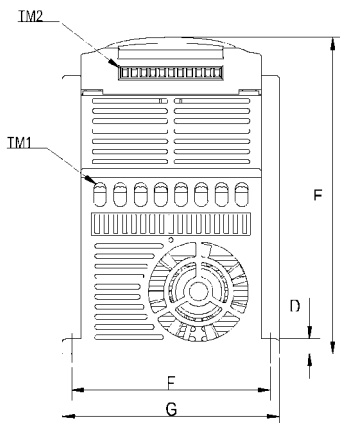
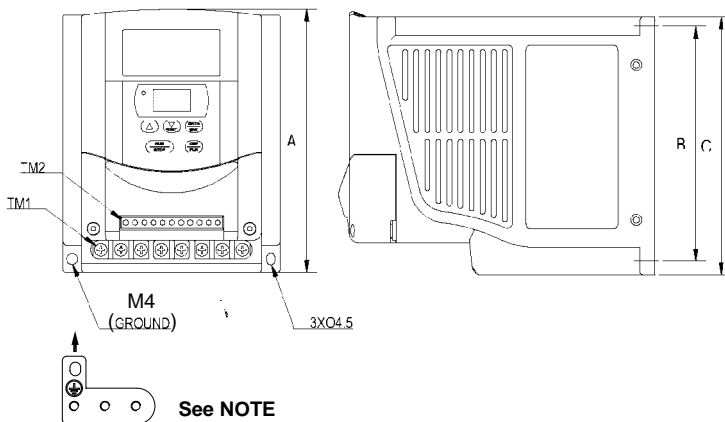

Unit :mm

Model	Dimension	A	B	C	D
S220 07/09 e T400		143.1	127.5	140	8.0
Model	Dimension	E	F	G	
S220 07/09 e T400		171.7	108	118	

**NOTE:** For safety reason, we strongly recommend users to remove the M4 grounding screw then screw the enclosed "metal frame grounding terminal" on the same location to make a grounding bar to ensure good earth protection.

**Mounting Instructions**

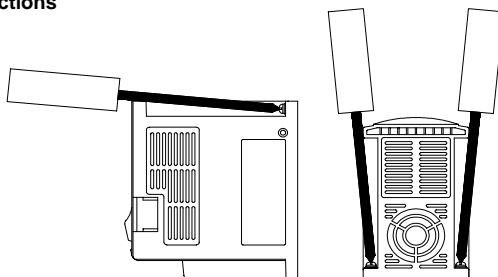

## Din rail mounting diagram

Step1-  
Aim and insert the 4  
retention ribs of the  
DIN Rail at the 4  
holes in rear panel  
of inverter

Step2-  
Push the DIN Rail  
forward until the  
middle rib grips  
firmly with back  
panel

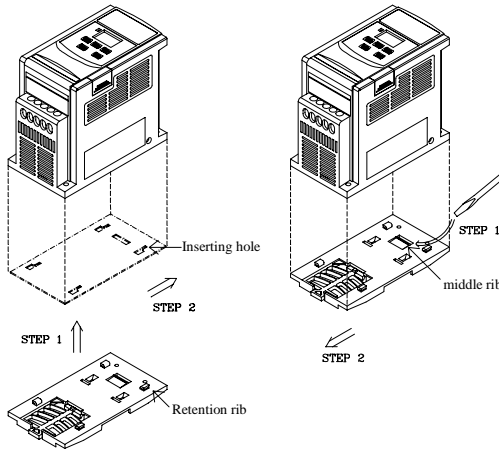

Step1-  
Use a small  
screwdriver  
inserting it into the  
middle rib of DIN  
Rail and press the  
screwdriver in  
order to remove  
the DIN Rail from  
inverter

## Additional DIN rail installation

A mounting clamp and a 35mm width rail must be used to install the drive on the rail

Installing drive

Dismounting drive

First place the groove on the back of the module on the upper edge of din rail, and then push the module down to lock up position. Finally press the mounting plate upward into module.

- ① Pull the mounting plate downward.
- ② Rotate the inverter module to dismount it.

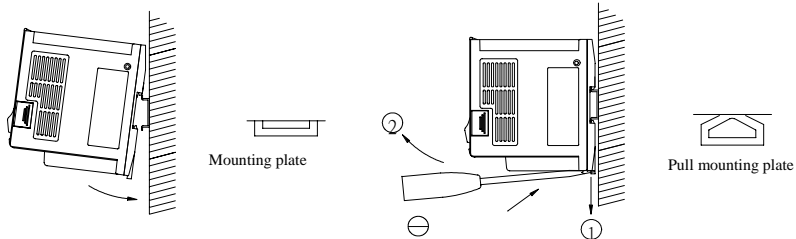

**SYN10 S 220 01/03/05 IP65 S (NEMA4)**

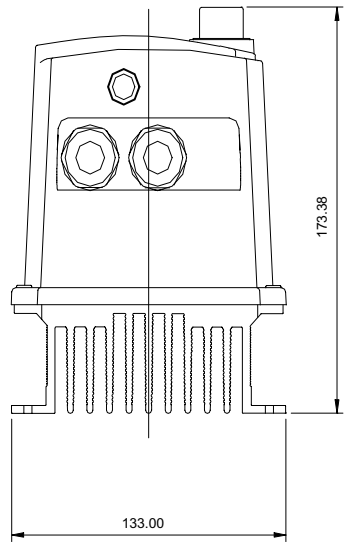
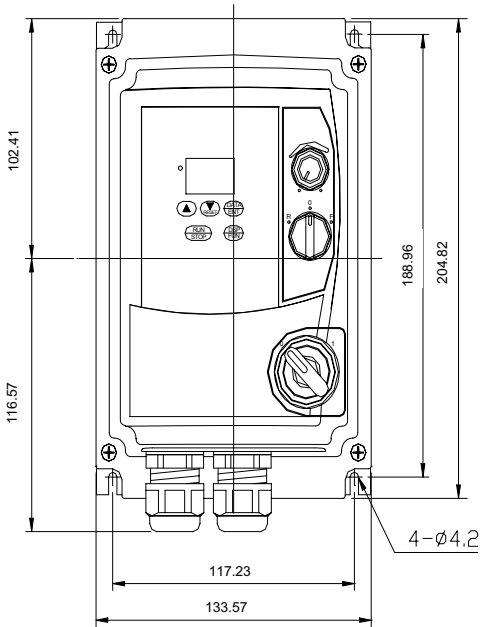

UNIT: mm

**SYN 10 S 220 01/03/05 IP65 S (NEMA4)**

**TYPE INSTALLATION:**

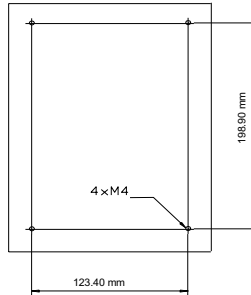
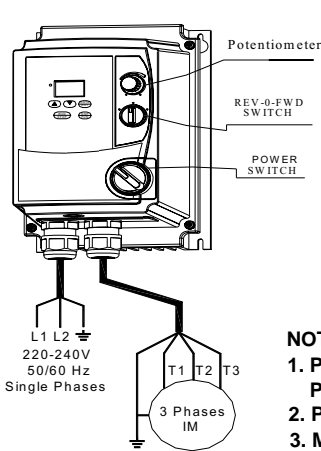

**NOTE:**

1. POWER SWITCH, REV-0-FWD SWITCH AND Potentiometer are only SYN 10 S 220 01/03/05 IP65 S TYPE
2. Power supply cable: # 14 AGE (2.0 mm<sup>2</sup>)
3. Motor cable: # 16 AGE (1.25 mm<sup>2</sup>)
4. Torque value of Screw:
  - (1). Power/Motor cable (plug in) Thermal: 5kg-cm (4.34 in-lb)
  - (2). Remote control wire: 4kg-cm (3.47 in-lb)
  - (3). Outer Cover (M4): 6kg-cm (5.20 in-lb)

**CIRCUIT DIAGRAM**

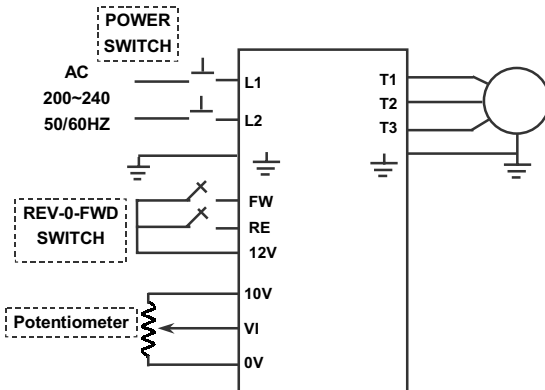

**NOTE:**

- (1). Input source: single-phase (L1,L2,  $\perp$ ) ensuring that it is connected to a 200/240V supply.
- (2). Output Motor: three-phase ( $\perp$ ,T1,T2,T3).

**Caution:**

- Do not start or stop the inverter using the main circuit power.
- FOR SYN 10 S 220 01/03/05 IP65 S TYPE Please always remain REV-0\_FWD switch at 0 position. In order to keep inverter has no running signal before power-on again after power supply interrupted. Otherwise, injury may result.
- FOR SYN 10 S 220 01/03/05 IP65 TYPE Please always remain RE or FW switch at OFF position. In order to keep inverter has no running signal before power-on again after power supply interrupted. Otherwise, injury may result.

**SYN10 S 220 01/03/05 IP65 (NEMA4) (WITHOUT SWITCH TYPE) CONNECTION & EMC MOUNTING:**

**CONNECTIONS**

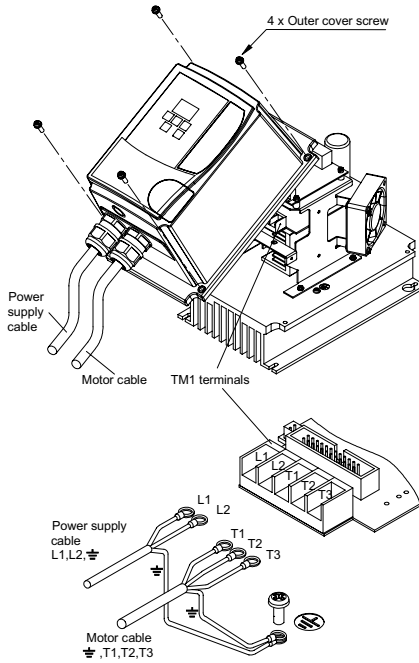

**EMC MOUNTING**

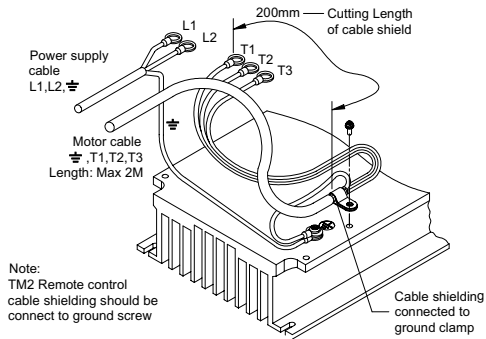

**SYN10 S 220 01/03/05 IP65 S (NEMA4) (WITH SWITCH TYPE) EMC MOUNTING & CONNECTIONS:**

**CONNECTIONS**

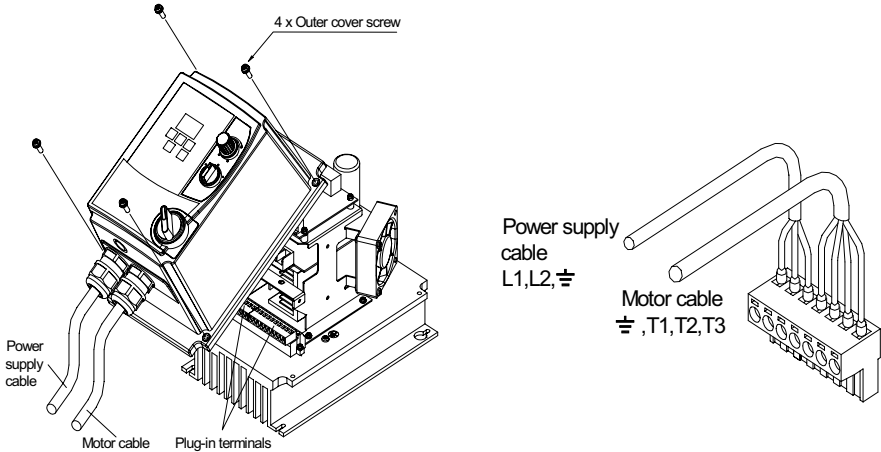

**EMC MOUNTING**

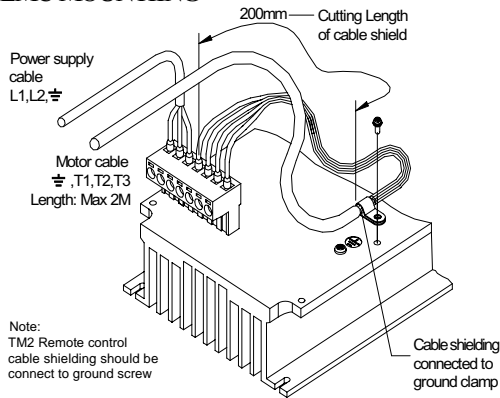

SYN10 S 220 07/09 IP65 S (NEMA4)

SYN10 T400 05/07/09 IP65 S (NEMA4)

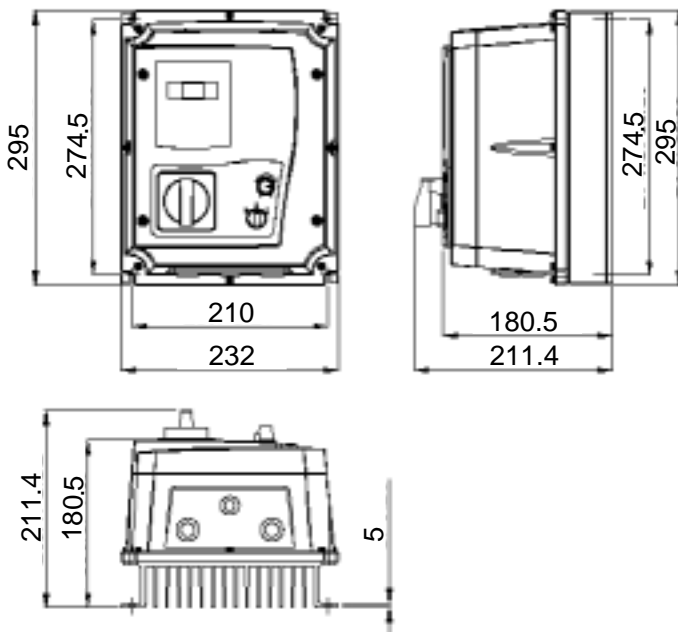

UNIT: mm

**SYN10 S 220 07/09 IP65 S – SYN10 T 400 05/07/09 IP65 S TYPE INSTALLATION:**

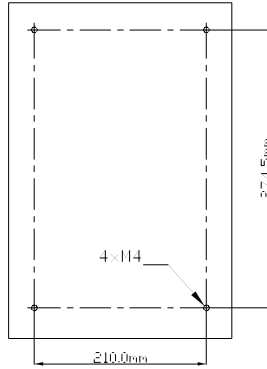
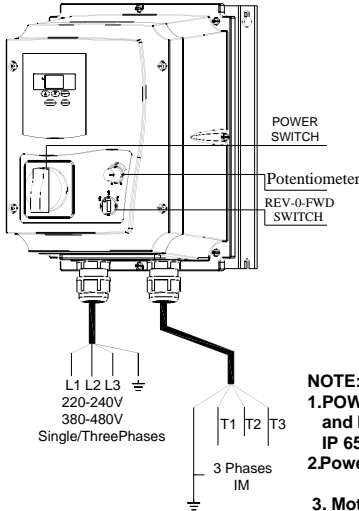

- NOTE:**
1. POWER SWITCH, REV-0-FWD SWITCH and Potentiometer are only for SYN10 IP 65 S TYPE
  2. Power supply cable : SYN10 S 220 #12AWG(3.5mm<sup>2</sup>)  
SYN10 T 400 #16AWG(1.25mm<sup>2</sup>)
  3. Motor cable : SYN10 S 220 #14AWG(2.0mm<sup>2</sup>)  
SYN10 T 400 #16AWG(1.25mm<sup>2</sup>)
  4. Torque value of Screw :  
(1). Power/Motor cable Terminal : 8 kgf-cm (6.94 in-lb)  
(2). Remote control wire : 4 kgf-cm (3.47 in-lb)  
(3). Outer Cover (M4) : 8kgf-cm (6.94 in-lb)

**CIRCUIT DIAGRAM**

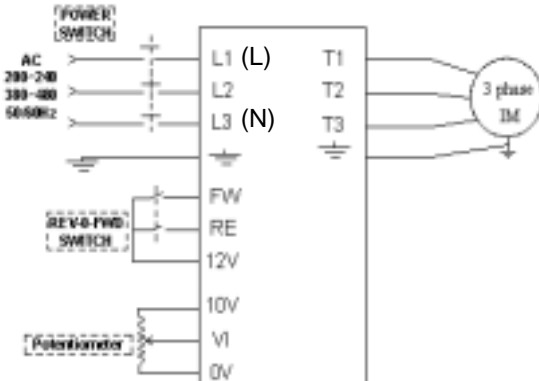

- NOTE:**
- (1). Input source:  
single-phase(L1,L2,  $\frac{\perp}{\text{N}}$ ) ensuring that it is connected to a 200/240 supply.  
or three-phase(L1,L2,L3,  $\frac{\perp}{\text{N}}$ ) ensuring that it is connected to a 200/240,380/460V supply.
  - (2). Output Motor: three-phase( $\frac{\perp}{\text{N}}$ , T1,T2,T3).

**Caution:**  
Do not start or stop the inverter using the main circuit power.

**FOR SYN 10 S 220 01/03/05 IP65 S TYPE**  
Please always remain REV-0-FWD switch at OFF position. In order to keep inverter has no running signal before power-on again after power supply interrupted. Otherwise, injury may result.

**FOR SYN 10 S 220 01/03/05 IP65 TYPE**  
Please always remain RE-or-FW switch at OFF position. In order to keep inverter has no running signal before power-on again after power supply interrupted. Otherwise, injury may result.



**SYN10 S 220 07/09 IP65 S – SYN10 T 400 05/07/09 IP65 S  
(WITH SWITCH TYPE) CONNECTIONS & EMC MOUNTING:**

**CONNECTION**

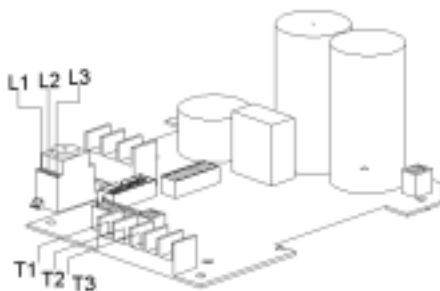
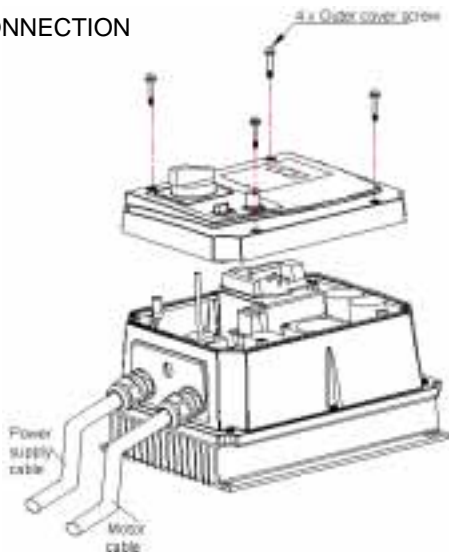

**EMC MOUNTING**

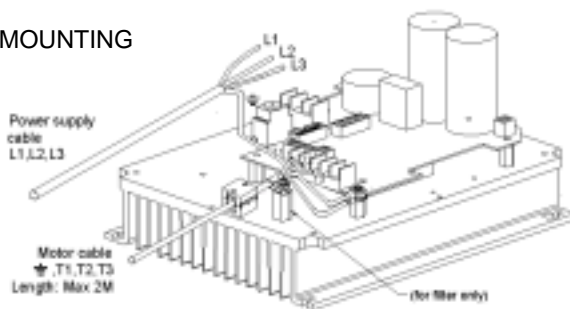

## Chapter 3 Software Index

### Keypad operating instructions -Keypad Description

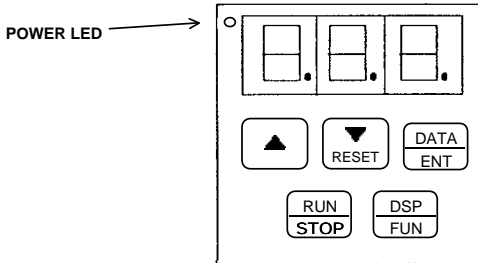

⚠ CAUTION

Do not operate keypad by screwdriver or other sharp-ended tool to avoid damaging keypad.

### Brief keypad operation flowchart

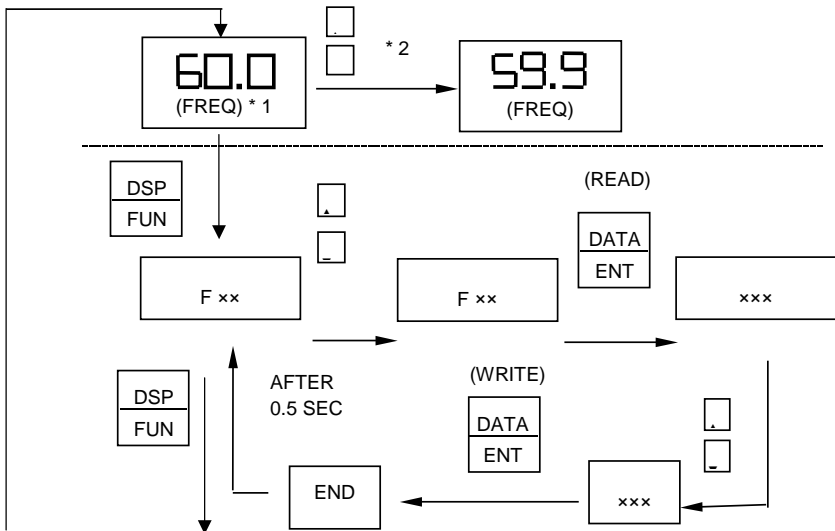

Note 1: Displayed setting of frequency when stopped. Display output frequency when running.

Note 2: The setting of the frequency can be modified either when stopped or when running.

## Parameter List

Function	F_	Function Description	Unit	Range	Factory setting	Page	Note
	00	Factory Adjustment			0	31	
Accel. Time	01	Acceleration time	0.1 sec	0.1 ~ 999 s	5.0	31	*1 *3
Accel. Time	02	Deceleration time	0.1 sec	0.1 ~ 999 s	5.0	31	*1 *3
Operation mode	03	0: Forward / Stop, Reverse / Stop 1: Run / Stop, Forward / Reverse	1	0 ~ 1	0	32	
Motor rotation direction	04	0: Forward 1: Reverse	1	0 ~ 1	0	32	*1
V/F Pattern	05	V/F pattern setting	1	1 ~ 6	1/4	33	*2
Frequency upper/lower limit	06	Frequency upper limit	0.1 Hz	1.0 ~ 200 Hz	50/60 Hz	34	*2 *3
	07	Frequency lower limit	0.1 Hz	0.0 ~ 200 Hz	0.0 Hz	34	*3
SP1 frequency	08	SP1 frequency	0.1 Hz	1.0 ~ 200 Hz	10 Hz	34	*3
JOG frequency	09	JOG frequency	0.1 Hz	1.0 ~ 200 Hz	6 Hz	34	
Start / Stop Control	10	0: Keypad 1: Terminal (TM2)	1	0 ~ 1	0	34	
Frequency Control	11	0 : Keypad 1 : Terminal (0 ~ 10v / 0 ~ 20 mA) 2 : Terminal (4 ~ 20 mA)	1	0 ~ 2	0	35	
Carrier frequency control	12	Carrier Frequency Control	1	1 ~ 10	5	35	
Torque compensation	13	Torque compensation gain	0.1%	0.0 ~ 10.0%	0.0%	37	*1
Stop method	14	0: controlled deceleration stop 1: free run stop	1	0 ~ 1	0	37	
DC braking setting	15	DC braking time	0.1 s	0.0 ~ 25.5 s	0.5 s	37	
	16	DC braking injection frequency	0.1 Hz	1 ~ 10 Hz	1.5 Hz	37	
	17	DC braking level	0.1%	0.0 ~ 20.0%	8.0%	37	
Electronic thermal Overload protection	18	Protection base on motor rated current	1%	0 ~ 200%	100%	38	
Multifunction input connection point	19	Multifunction input terminal 1 (SP1) function	1: Jog 2: Sp1 3: Quick stop 4: External Base Block 5: Reset 6: SP2		2	39	
	20	Multifunction input terminal 2 (RESET) function			5	39	
Multi-function output	21	Multifunction output terminal	1: Operating 2: Frequency reached 3: Fault		3	39	

Function	F_	Function Description	Unit	Range	Factory setting	Page	Note
Reverse Lock-Out	22	0: REV run 1: REV run Lock-Out	1	0 ~ 1	0	40	
Momentary power loss	23	0: enabled 1: disabled	1	0 ~ 1	0	41	
Auto restart	24	Number of Auto-restart times	1	0 ~ 5	0	41	
Factory setting	25	010: Constants initialization to 50Hz system 020: Constants initialization to 60Hz system				42	*2
SP2 frequency	26	SP2 frequency	0.1Hz	1.0~200Hz	20	42	
SP3 frequency	27	SP3 frequency	0.1Hz	1.0~200Hz	30	42	
Direct start	28	0:enable 1:disable	1	0 ~ 1	1	42	*4
Software version	29	CPU program version				42	
Fault Log	30	Fault log for three faults.				42	

**NOTE:**

\*1: Indicate this parameter can be adjusted during running mode.

\*2: Please refer to F\_25.

\*3: If the setting range is above 100, the setting unit becomes 1.

\*4: New function for CPU version v2.1 and above

## Parameter function description

F\_00 Factory adjustment parameter. Do not change.

F\_01 : Acceleration time = 0.1 ~ 999 sec

F\_02 : Deceleration time = 0.1 ~ 999 sec

**1. Acceleration / Deceleration time calculation formula:**

$$\text{Accelerate time} = F_{01} \times \frac{\text{Setting Frequency}}{50 \text{ Hz}}$$

$$\text{Decelerate time} = F_{02} \times \frac{\text{Setting Frequency}}{50 \text{ Hz}}$$

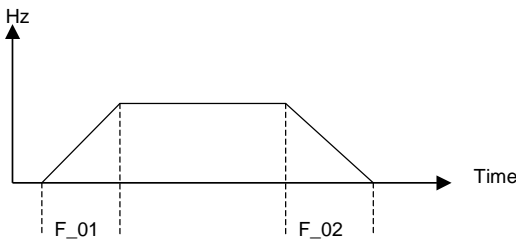



**F\_05: V/F pattern setting = 1 ~ 6**

Selecting F\_05 = 1-6 to select one of the six preset V/F patterns. (Refer to the following tables)

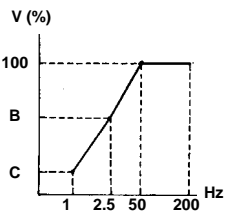
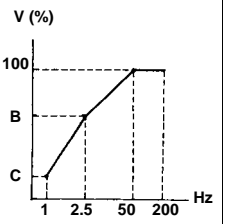
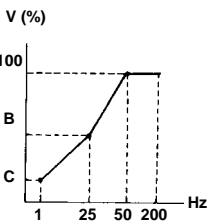
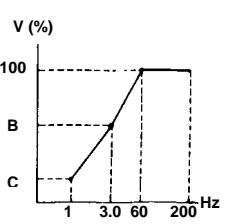
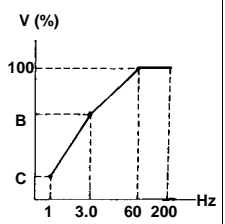
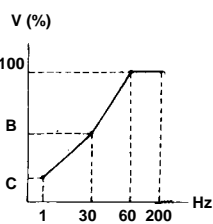
Specification	50 Hz System		
Application	General Application	High starting torque	Decreasing torque
F_5	1	2	3
V/F pattern			
Specification	60Hz System		
Application	General Application	High starting torque	Decreasing torque
F_5	4	5	6
V/F pattern			

F_5	B	C
1/4	10%	8%
2/5	15%	10.5%
3/6	25%	7.7%

F\_06: frequency upper limit range=1~200Hz

F\_07: frequency lower limit range=1~200Hz

**F\_06: Factory setting refers to F\_25.**

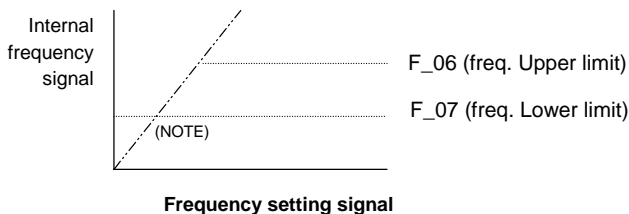

**NOTE:**

**If F\_07 = 0 Hz, The frequency instruction is equal to 0Hz, the inverter will stop at 0 speed.**

**If F\_07 > 5 Hz, The frequency instruction F\_07, the inverter will output a minimum speed according to the setting in F\_07**

F\_08: SP1 frequency = 1 ~ 200Hz

F\_09: JOG frequency = 1 ~ 200Hz

1. When F\_19 or F\_20 = 2 and the multifunction input terminal is ON, the inverter operates at sp1 frequency (F\_08)
2. When F\_19 or F\_20 = 1 and the multifunction input terminal is ON, the inverter operate at jog frequency (F\_09)
3. The priority of reading frequency setting is: Jog → Sp1 → Keypad setting or external frequency signal using a speed pot.

F\_10: Start / Stop Control

= 0: Keypad

= 1: Terminal (TM2)

**NOTE: When F\_10=1 (Terminal Control), quick stop on the Keypad is enabled.**

When F\_10=1, please refer to the descriptions of F\_23/24, in order to avoid the damage to the human and the machine.

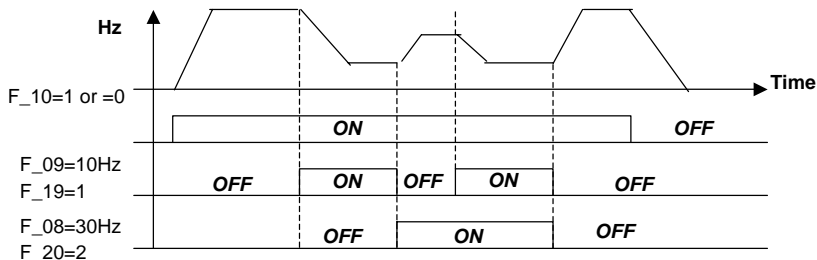

**F\_11: Speed Control**

- = 0: Keypad
- = 1: Analog Speed Pot Terminal (TM2) (0 ~ 10V / 0-20mA)
- = 2: ( 4-20mA ) (TM2)

**NOTE 1:**

When jog frequency or Sp1 frequency is switched on, the frequency is setup by Sp1 speed, the ▲ and ▼ buttons on the keypad is disabled.

Original setting will be restored after the Sp1 connection is removed.

**NOTE2:**

During the contact closure of the jog function, the keypad control remains in a sleep state until the jog contact connection is re-opened.

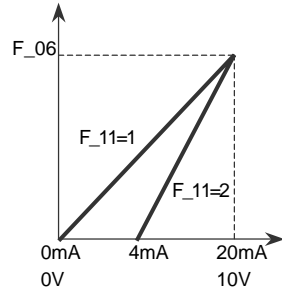

**F\_12: Carrier Frequency = 1 ~ 10**

F_12	Carrier frequency	F_12	Carrier frequency	F_12	Carrier frequency
1	4 kHz	5	8 kHz	9	15 kHz
2	5 kHz	6	10 kHz	10	16 kHz
3	6 kHz	7	12 kHz		
4	7.2 kHz	8	14.4 kHz		

**NOTE IF F\_12=7~10, the inverter must operator with low load.**

Although an IGBT TYPE inverter can provide a low audible noise level during its operation, it is possible that the switching of the high carrier frequency may interfere with external electronic components (or other controllers) or even cause vibration in the motor. Adjusting the carrier frequency can usually correct this problem.

**Output currents in function of PWM frequency (parameter F\_12):**

	<b>4kHz - 7.2kHz</b> (F_12 = 1...4)	<b>8kHz</b> (F_12 = 5)	<b>10kHz</b> (F_12 = 6)	<b>12kHz</b> (F_12 = 7)	<b>14.4kHz</b> (F_12 = 8)	<b>15kHz</b> (F_12 = 9)	<b>16kHz</b> (F_12 = 10)
<b>SYN10 S 220 01 AF</b>	1.4 A	1.4 A	1.3 A	1.3 A	1.2 A	1.1 A	1.1 A
<b>SYN10 S 220 03 AF</b>	2.3 A	2.3 A	2.3 A	2.3 A	2.3 A	2.3 A	2.3 A
<b>SYN10 S 220 05 AF</b>	4.2 A	4.2 A	4.2 A	4.1 A	4.1 A	4 A	4 A
<b>SYN10 S 220 07 AF</b>	7.5 A	7.5 A	7.5 A	7.5 A	7.5 A	7.5 A	7.5 A
<b>SYN10 S 220 09 AF</b>	10.5 A	10.5 A	10 A	9.8 A	9.4 A	9.3 A	9 A
<b>SYN10 T 400 05 AF</b>	2.3 A	2.3 A	2.3 A	2.3 A	2.3 A	2.3 A	2.3 A
<b>SYN10 T 400 07 AF</b>	3.8 A	3.8 A	3.8 A	3.8 A	3.8 A	3.8 A	3.8 A
<b>SYN10 T 400 09 AF</b>	5.2 A	5.2 A	5.2 A	5.2 A	5.2 A	5.2 A	5.2 A

**F\_13: Torque compensation gain = 0 ~ 10 %**

To enhance Inverter output torque patterns according to the B, C voltage points on the V/F pattern (refer to F\_05 description) and the (F\_13) for this feature.

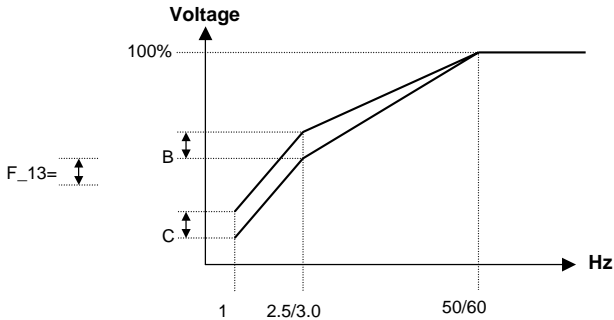

**NOTE: When F\_13 = 0, the torque boost function is disabled.**

F_14 Stopping method	= 0 : Controlled deceleration stop = 1 : free run to stop
F_15 DC braking time	= 0 ~ 25.5 sec
F_16 DC braking starting frequency	= 1 ~ 10 Hz
F_17 DC braking level	= 0 ~ 20 %

**If F\_14 = 0**

When the inverter receives the stop command, it decelerate to the pre-set frequency setup by F\_16 after this the output voltage level that is set in the F\_17; will determine the amount of DC voltage that's injected into the motor. The time duration to perform this stopping function is setup in F\_15.

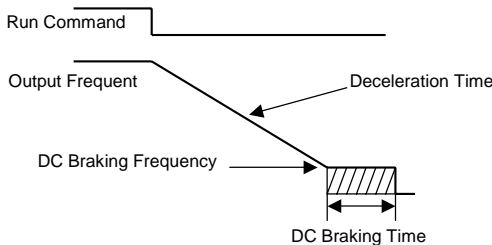

**If F\_14 = 1**

The inverter stops output immediately after receiving the stop command. The motor will enter into a free running state until it comes to a complete stop.

F\_18: Motor rated current = 0~200 %

### 1. The electronic thermal overload protection for motor:

- (1) Motor rated current = Inverter rated current x F\_18  
 $F_{18} = \text{Motor rated current} / \text{inverter rated current}$
- (2) When the load is within 100% of the motors rated current, the operation continues. When the load reaches 150% of the motors rated current the operation is allowed to continue for 1 minute. (Refer to curve (1) in Figure 3)
- (3) After protecting the motor with the electronic thermal switch activated, the inverter is cut off immediately. The OLI light will flash. To resume operation, push the RESET button or activate an external reset connection wired to terminal TM2.
- (4) When the motor is operating at low speeds, the heat dissipation efficiency is lower. The electronic thermal activation level is also reduced. (to change from curve (1) to curve (2) in Figure 3. Choose the appropriate F\_05 setting according to the applied motor to reach the desired performance.

### 2. The electronic thermal protecting for inverter:

- (1) When the load is within 103% of the inverters rated current, the operation continues. When the load reaches 150% of rated current of the inverter, the operation will continue for 1 minute. (Refer to curve (1) of figure 3)
- (2) After the activation of the electronic thermal switch, the inverter is shut off immediately. The OL2 light will flash. To resume the operation, push RESET button or activate an external reset contact on terminal TM2.

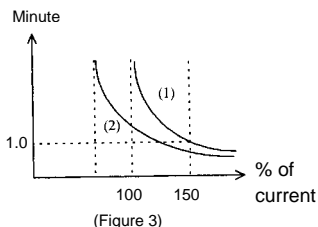
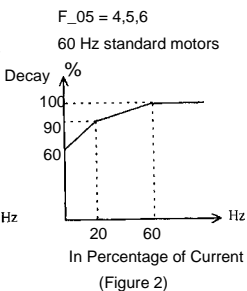
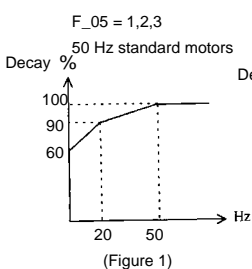

F\_19: Multifunctional input terminal 1 function = 1~ 6

F\_20: Multifunctional input terminal 2 function = 1~ 6

**1. F\_19=1 or F\_20 =1: JOG control (refer to F\_09)**

**2. F\_19, F\_20 =2 or 6 Multi-speed control:**

**F\_19=2 & F\_20=6:**

TM2 SP1 Terminal	TM2 RESET Terminal	Output frequency
ON	OFF	F_08
OFF	ON	F_26
ON	ON	F_27

**F\_19=6 & F\_20=2:**

TM2 SP1 Terminal	TM2 RESET Terminal	Output frequency
ON	OFF	F_26
OFF	ON	F_08
ON	ON	F_27

**3. F\_19, F\_20 =3: External quick stop**

When the external quick stop signal is activated, the inverter proceeds to decelerate (by deceleration time set on F\_02) and stop, (ignoring the setting of F\_14). The inverters E.S. light will flash after stopping. After the quick stop signal is deactivated, turn the RUN switch OFF and then ON again to cycle it. (F\_10 =1) Or, push the RUN key (F\_10=0). The inverter will then resume operation and restart. If the quick stop signal is removed before the inverter stops, the inverter will still execute the quick stop. If an alarm will occur, the motor will coast to a stop.

**4. F\_19, F\_20 =4: External Base Block (Immediate Shut Down)**

When the external base block signal is activated, the inverter output will be immediately shut off (ignoring the setting of F\_14) and flash b.b. Light. After the base block signal is deactivated, turn the RUN switch OFF and then ON again (F\_10 = 1) or push the RUN key (F\_10=0), the inverter will restart from the original starting frequency.

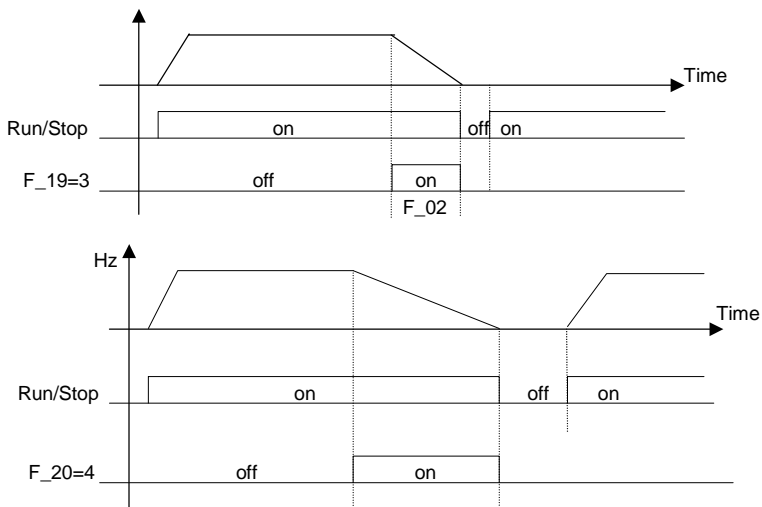

**5. F\_19, F\_20 = 5: Auto Reset when inverter faults.**

F\_21: Multi-function output terminal control = 1 ~ 3

1. F\_21 = 1: Run mode signal
2. F\_21 = 2: At Frequency Speed Signal
3. F\_21 = 3: Fault signal

Terminal1 and2 of TM2 are activated at CPF, OL1, OL2, OCS, OCA, OCC, Ocd , Ocb , OVC , LVC , OHC.

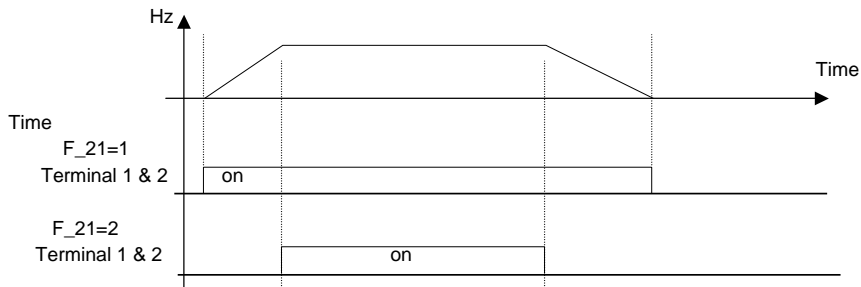

F\_22: Reverse Lock-Out = 0: REV command  
= 1: REV command Lock-out

**NOTE:**

When F\_04 is set to 1 (reverse), F\_22 cannot be set to 1, in order to properly lockout a motors direction, F\_04 must be set at 0 before setting F\_22 to 1.

### F\_23: Auto-restart after momentary power loss

=0: auto-restart enabled

=1: auto-restart disabled

1. When the AC power supply is temporary below low voltage protection levels because of power company issues or encountering large current loading in the same power supply system, the inverter will stop its output immediately. If the power source resumes within 2 seconds, the inverter can restart by using its speed search program.
2. When F\_23=0:
  - (1) If the momentary power loss is less than 2 seconds, the inverter resume operation automatically via speed search at 0.5 seconds after power up. The number of auto-restart times is not limited by F\_24.
  - (2) If the momentary power loss is long, the operation of the inverter is based on the setup of F\_10 and the condition of external switch.
  - (3) If the time of momentary loss is between the above two, whether the inverter will auto-restart depends on F\_24:
    - F\_24=0: auto-restart disabled.
    - F\_24=1~5: auto-restart enabled 1~5 times.
3. When F\_23=1,
  - (1) Power up after momentary power loss, the inverter will not start. Even under F\_24>0.
  - (2) If the momentary power loss is long, the inverter must be restart manually. The operation of the inverter is based on the setup of F\_10 and the condition of external switch.
4. When restart the inverter, the operation of the inverter is based on the setup of F\_10 and the condition of external switches (FWD/REV button).
  - (1) When F\_10=0, the inverter will not start after restart.
  - (2) When F\_10=1 and the external switch (FWD/REV button) is OFF, the inverter will not start after restart.
  - (3) When F\_10=1 and the external switch (FWD/REV button) is ON, the inverter will start automatically after restart. Attention: Base on safety reason, please turn off the external switch (FWD/REV button) after power loss to avoid possible damage to the machine and the human body after sudden regeneration of power.

### F\_24: Number of Auto-restart times = 0~5

1. When F\_24=0, the inverter will not auto-restart after a malfunction break away from operation. (Except for momentary power loss, please refer to F\_23 for details)
2. When F\_24=1~5: the inverter will resume operation via speed search at 0.5 second under auto-restart after malfunction break away. (Except for momentary power loss, please refer to F\_23 for details).
3. When the inverter is set to deceleration or DC breaking, the transient restart procedure is not performed.

4. If either of following situations should develop, the auto restart times will be reset:
- (1) No additional malfunction (in operation or stop) occurs within 10 minutes.
  - (2) Press RESET button.

#### F\_25: Return to Factory Pre-Settings

= 010: Constants initialization to 50Hz system

= 020: Constants initialization to 60Hz system

1. When F\_25 is set to 010, all parameters are restored to factory settings. The settings of F\_05 = 1 and F\_06 = 50. F\_25 is restored back to 000 after the reset process is complete. (50Hz operation)
2. When F\_25 is set to 020, all parameters are restored to factory settings. The settings of F\_05 = 4 and F\_06 = 60. F\_25 is restored back to 000 after the reset process is complete. (60Hz operation)

#### F\_26: SP2(1~200Hz) , Multi-speed2 (Reference to F\_19 & F\_20)

#### F\_27: SP3(1~200Hz) , Multi-speed3 (Reference to F\_19 & F\_20)

#### F\_28: Direct start

= 0 : Direct start enable when remote Run command on

= 1 : Direct start disable when remote Run command on

When F\_28 = 1 and control mode is remote control (F\_10 = 1), Inverter can not start if RUN switch is ON when power is engaged, Must be turned the RUN switch OFF and turned ON again, Then Inverter can start.

#### F\_29: CPU program version

#### F\_30: Last three faults

1. Last three faults: indicate the sequence of the occurrence of malfunctions by the location of decimal point. **x.xx** indicates a recently happened malfunction. **xx.x** indicates the last malfunction that happened. **xxx**. Indicates the earliest malfunction in the record.
2. After entering the F\_30 function, the **x.xx** trip record will be displayed first. After that, press ▲ button and you can read activity in a chronological order. **xx.x** → **xxx**. → **x.xx** → ..., consecutively.
3. After entering F\_30 function, if the RESET button is pressed, the trip record will be cleared. Indication display **-.-**, **--.**, and **---**.
4. When the content of trip indicates O.CC, it will indicate the latest trip code is OC-C and so on.

## Malfunction Indications and Countermeasures

### 1. Manual reset inoperative malfunctions

INDICATION	CONTENT	POSSIBLE CAUSE	COUNTERMEASURE
<b>CPF</b>	Program error	Outside noise interference	Place a RC surge absorber in parallel with the noise generating magnetic contact
<b>EPR</b>	EEPROM error	EEPROM defective	Replace EEPROM
<b>OV</b>	Voltage too high while not operating	1.Power source voltage too high. 2.Detection circuitry defective	1. Examine the power supply 2.Return the inverter for repair
<b>LV</b>	Voltage too low while not operating	1.Power source voltage too low. 2.Detection circuitry defective.	1.Examining the power supply 2.Return the inverter for repair
<b>OH</b>	Inverter over heat while not operating	1.Detection circuit defective. 2.Environment over-heat or poor ventilation	1.Return the inverter for repair 2. Improve ventilation

### 2. Manual reset operative malfunctions (Auto-Reset inoperative)

INDICATION	CONTENT	POSSIBLE CAUSE	COUNTERMEASURE
<b>OC</b>	Over-current at stop condition	Detection circuit malfunction	Return the inverter for repair
<b>OL1</b>	Motor over-load	1. Loading too large 2. Improper V/F model setting 3. Improper F_18 setting	1. Increase capacity of motor 2. Adjust to use a proper V/F curve setting 3. Adjust F_18 according to instruction
<b>OL2</b>	Inverter over-load	1. Loading too large 2. Improper V/F model setting	1. Increase capacity of inverter 2. Adjust to use a proper V/F curve setting

### 3.Manual Reset and Auto-Reset Operative Malfunction

INDICATION	CONTENT	POSSIBLE CAUSE	COUNTERMEASURE
<b>OCs</b>	Transient over-current starting machine	<ol style="list-style-type: none"> <li>1.Motor coil short-circuit with external casing</li> <li>2.Motor connection wire short-circuit with grounding</li> <li>3.Transistor module damaged</li> </ol>	<ol style="list-style-type: none"> <li>1.Examining motor</li> <li>2.Examining wiring</li> <li>3.Replace transistor module</li> </ol>
<b>OCA</b>	Over-current at acceleration	<ol style="list-style-type: none"> <li>1.Acceleration time setting too short</li> <li>2.Improper V/F feature selection</li> <li>3.Applied motor capacity exceeds inverter capacity</li> </ol>	<ol style="list-style-type: none"> <li>1.Adjust acceleration time to longer setting</li> <li>2.Adjust to a proper V/F curve</li> <li>3.Replace and install another inverter with appropriate capacity</li> </ol>
<b>OCC</b>	Over-current at steady speed	<ol style="list-style-type: none"> <li>1.Transient alteration of the loading</li> <li>2.Transient alteration of the power supply</li> </ol>	<ol style="list-style-type: none"> <li>1.Examining the loading configuration</li> <li>2.Install inductor on the power supply input side</li> </ol>
<b>OCd</b>	Over-current at deceleration	Deceleration setting too short	Adjust to use a longer acceleration time
<b>OCb</b>	Over-current at breaking	DC Breaking frequency, breaking voltage, or breaking time setting too long	Adjust to reduce settings of F_15, F_16, or F_17
<b>OVC</b>	Over-voltage at operation/deceleration	<ol style="list-style-type: none"> <li>1.Deceleration time setting too short or inertial loading too large</li> <li>2.Power supply voltage variation too large</li> </ol>	<ol style="list-style-type: none"> <li>1.Adjust to use a longer deceleration time</li> <li>2.Install a inductor on the power supply input side</li> <li>3.Increase the capacity of inverter</li> </ol>
<b>LVC</b>	Insufficient voltage level at operation	<ol style="list-style-type: none"> <li>1.Power supply voltage too low</li> <li>2.Power supply voltage variation too large</li> </ol>	<ol style="list-style-type: none"> <li>1.Improve power source quality</li> <li>2.Adjust to use a longer acceleration time</li> <li>3.Increase capacity of inverter</li> <li>4.Install a reactor on the power supply input side</li> </ol>
<b>OHC</b>	Heat-sink over heated at operation	<ol style="list-style-type: none"> <li>1.Loading too heavy</li> <li>2.Ambient temperature too high or poor ventilation</li> </ol>	<ol style="list-style-type: none"> <li>1.Examining the loading</li> <li>2.Increase capacity of inverter</li> <li>3.Improve ventilation</li> </ol>

## Special Condition Description

INDICATION	CONTENT	DESCRIPTION
SeS	Zt In D2t tu Dn2203	W7t n e <sub>TT</sub> = PEe <sub>W</sub> P r nu 0 qnt nsi at 003 < T H( W7t n e <sub>TT</sub> = TEe <sub>W</sub> (e <sub>6ITPP</sub> )Er nu 0 qnt nsi at 003 <(e <sub>6ITPP</sub> )
SP1	Fail to start directly	1. If the inverter is set to external operation (F <sub>10</sub> = 1) and direct start is disabled (F <sub>28</sub> =1), the inverter cannot be started and will flash SP1 when operation switch turned ON before applying power (see descriptions of F <sub>28</sub> ). 2. Direct start is possible when F <sub>28</sub> = 0.
Se2	Rt i 2ru t b t l3t nsi aon2	w7t 06t l d l at on2 on t z d lnr hn2t l r on (e <sub>TP</sub> =T)AV07t Dw, - +ti 0 07t +ti 2ru 0 2lt aat u r o7t b 0uit nOn2t l r onE07t 06t l d l aon2a r ssnlu03 07t at 003 0 e <sub>T</sub> . r nu 0ra7 D- p r 0 l aon2Aw7t RU9 aV07 b naoH intnt u, ee 07r n, 9 on lt ar lo 07t b r s70t A
-LVV	%zd lnr h t b t l3t nsi aon2	W7t n 07t t z d lnr ht b t l3t nsi aon2 a0nr h0 r s06r d u 07lnr87 07t b n0ns0n 02no d lb 0r E07t 06t l d l ut st H l r d a r nu aon2aAV06t l d l 0ra7t a %DAr 0 l aon2aA(Rt 0 l on 0adns0n 0 l e <sub>Tc</sub> 0 l ut 0 0A
/VV	%zd lnr h* AD% * L, 4R	W7t n 07t t z d lnr h* AD%* L, 4 R a0nr h0 r s06r d u 07lnr87 07t b n0ns0n d lb 0r E07t 06t l d l aon2 nm2no0 b t u0d h r nu 0ra7 HAA0 l 0uGr 0nA(Rt 0 l on 0adns0n 0 l e <sub>Tc</sub> 0 l ut 0 0)

## Keypad Operation Error Instruction

INDICATION	CONTENT	POSSIBLE CAUSE	COUNTERMEASURE
LOD	1 nonl u0t s0n lms+tu	TAA0 b 2oon lt 6t lat u0t s0n V7t n e <sub>pp</sub> = T pAA0 b 2oon at oe <sub>pp</sub> on T V7t n e <sub>P</sub> = T	TAAuyraoe <sub>pp</sub> on P pAAuyraoe <sub>P</sub> . on P
-r1	Rt i 2ru n2t l r on t l l n l	TA- lt aa ▲ nl ▼ +tia V7t n e <sub>TT</sub> =T nl mmut l a2T n2t l r on pAA0 b 2oon b nu0 e <sub>pc</sub> fAA0 b 2oon b nu0 2r l r b t d l 07ro 0 nno r H nVt u on H b nu0 u umt 03 n2t l r on (lt 0 l on 2r l r b t d l 00)	TAUat ▲ nl ▼ +tia on r uyrao0 qnt nsi at 003 nnh r 0 l e <sub>TT</sub> =P pAx n nno b nu0 e <sub>pc</sub> f A1 nu0 0 aon2 b nut
-r2	- r l r b t d l at 003 t l l n l	T Ae <sub>6</sub> ≤ e <sub>W</sub>	T Ae <sub>6</sub> > e <sub>W</sub>

## General Malfunction Examination Method

ABNORMALITY	CHECK POINT	COUNTERMEASURE
<b>Motor Inoperative</b>	Is the power source voltage delivered to L1, L2 terminal (is the charging indicator illuminated)?	<ul style="list-style-type: none"> <li>• Check if the power source on.</li> <li>• Turn power source OFF and then ON again.</li> <li>• Reconfirm the power voltage level.</li> </ul>
	Is there voltage output from output terminal T1, T2 and T3?	<ul style="list-style-type: none"> <li>• Turn power source OFF and then ON again.</li> </ul>
	Is the motor wired correctly?	<ul style="list-style-type: none"> <li>• Check motor wiring.</li> </ul>
	Is there any abnormal condition of the inverter?	<ul style="list-style-type: none"> <li>• Refer to malfunction handling instructions to examine and correct wiring.</li> </ul>
	Is the forward or reverse instruction loaded?	
<b>Motor Inoperative</b>	Is the analog frequency setting loaded?	<ul style="list-style-type: none"> <li>• Check to see if wiring for analog frequency input signal is correct?</li> </ul>
	If the operation mode setting correct?	<ul style="list-style-type: none"> <li>• Check if the frequency input setting voltage is correct?</li> </ul>
<b>Motor operate in opposite direction</b>	Is wiring on the output terminals T1, T2 and T3 correct?	<ul style="list-style-type: none"> <li>• Operate by digital?</li> </ul>
	Is the wiring for the forward and reverse signals correct?	<ul style="list-style-type: none"> <li>• Wiring should be in accordance with the U, V, W terminals of motor.</li> </ul>
<b>Motor operation speed fixed</b>	Is the wiring for analog frequency input correct?	<ul style="list-style-type: none"> <li>• Examining the wiring and correct it.</li> </ul>
	Is the operation mode setting correct?	<ul style="list-style-type: none"> <li>• Examining the wiring and correct it.</li> </ul>
	Is the loading too heavy?	<ul style="list-style-type: none"> <li>• Check the Operation panel</li> </ul>
<b>Motor operation at speed too high or too low</b>	Is the specification of motor (poles, voltage) correct?	<ul style="list-style-type: none"> <li>• Reduce loading</li> </ul>
	Is the gear ratio correct?	<ul style="list-style-type: none"> <li>• Reconfirm motor specification.</li> </ul>
	Is the highest output frequency setting correct?	<ul style="list-style-type: none"> <li>• Reconfirm gear ratio</li> </ul>
	Is the voltage on motor side reduced extremely?	<ul style="list-style-type: none"> <li>• Reconfirm highest output frequency</li> </ul>
<b>Abnormal speed variation at operation</b>	Is the loading too heavy?	<ul style="list-style-type: none"> <li>• Reduce loading variation</li> </ul>
	Is the loading variation too large?	<ul style="list-style-type: none"> <li>• Increase inverter and motor capacity</li> </ul>
	Is the input power source steady and stable?	<ul style="list-style-type: none"> <li>• Install AC reactor on the power supply input side</li> </ul>

## Routine examination and periodical examination

Inverter requires routine and periodical examination and maintenance

Carry out the examination only after the “ Power LED ” indicator goes off for at least 5 minutes

Maintenance item	Maintenance description	Examination period		Examination method	Criterion	Countermeasure
		Routine	1 Year			
Installation site environment	Reconfirm environment temperature and humidity	○		Refer to installation instructions and measure with thermometer and hygrometer	Temperature: -10~40 OC Humidity: under 95% without condensing	Improve installation site environment
	Check and remove any flammable material nearby	○		Visual inspection	No foreign object	
Inverter Installation and Grounding	Is there any abnormal vibration on the installation site?	○		Visual and audio inspection	No foreign object	Tighten loose screw
	Is the grounding resistance within acceptable range?		○	Measure resistance by multi-meter	200V class under 100 ohm	Improve grounding
Input power source voltage	Is the voltage of the primary circuitry normal?	○		Measure voltage by multi-meter	Voltage level conforming specification	Improve input power source
Inverter external terminal mounting screw	Is the tighten parts secured?		○	Visual inspection. Use screwdriver to verify screw tightness	No abnormality	Tighten loose screw or return for repair
	Is there any sign of breakage on the terminal panel?		○			
	Is there any obvious rusty condition?		○			
Internal wiring of inverter	Is it deformed or skewed?		○	Visual inspection	No abnormality	Replace or return for repair
	Is the insulation of wire broken?		○			
Heat-sink	Is it accumulating dust or dirt?	○		Visual inspection	No abnormality	Clean up dust or dirt
PCB	Is it accumulating conductive metal or oil stain?		○	Visual inspection	No abnormality	Clean up or replace PCB
	Is there any over-heated or burnt component?		○			
Cooling fan	Is there any abnormal vibration or noise?		○	Visual and audio inspection	No abnormality	Replace cooling fan
	Is it accumulating dust or dirt?	○		Visual inspection		Clean up
Power component	Is it accumulating dust or dirt?		○	Visual inspection	No abnormality	Clean up
Capacitor	Is there any sign of strange order or leakage?	○		Visual inspection	No abnormality	Replace capacitor or inverter
	Is there any sign of swelling or bulging?	○				

## Maintenance and Examination

Frequent examination and maintenance is not required for the inverter.

To maintain appropriate reliability, please proceed with following periodical examination. Remember to turn off power supply and wait till the Power LED goes off before proceed. (Due to the large amount of remaining charges in the internal capacitors.)

- (1) Clean out internal dust and dirt.
- (2) Check out mounting screws on every terminal and parts. Tighten loose screws.
- (3) Dielectric strength test
  - (a) Remove all conducting wires between Drive and outside world. Power must be turned OFF.
  - (b) The dielectric strength test inside Drive should be carried out only for T-VERTER major circuitry. Use DC 500V: high resistance meter. Measured resistance should be higher than 100M ohm.

**CAUTION: Do not perform dielectric strength test to the control circuit.**

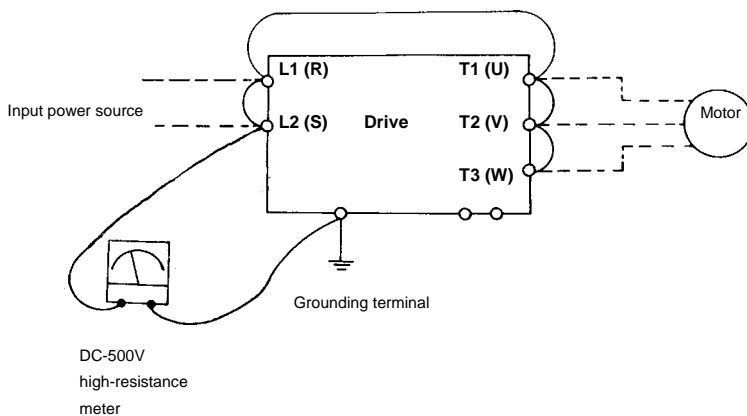

**Connection for dielectric strength test**

## Voltage Current Measurement

The voltage and current measurement on the primary and secondary side of the inverter may be different due to instrumentation variations. Refer to following diagram for measurement:

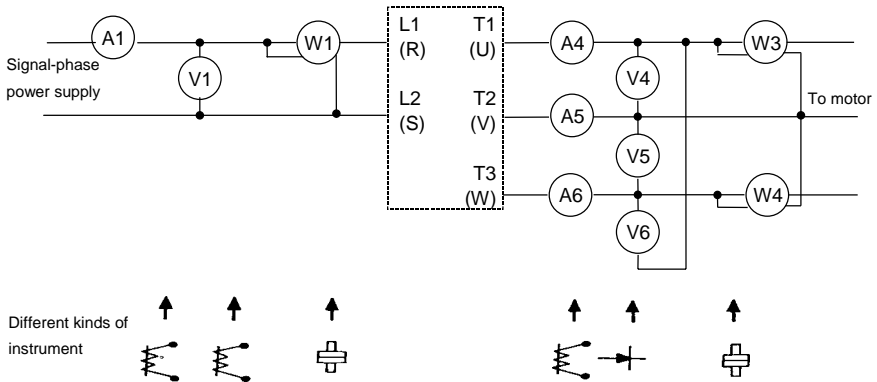

Measurement	Measuring point	Instrument	NOTE (Measurement criterion)
Input voltage $V_i$	(V1)	Moving-iron	
Input current $I_i$	(A1)	Moving-iron	
Input power $P_i$	(W1)	Power-meter	$P=W1$
Input power factor $PF_i$	Calculate power factor by the input voltage, input current and input power $PF_i = \frac{P_i}{\sqrt{3}V_i \cdot I_i} \times 100\%$		
Output voltage $V_o$	(V4) (V5) (V6)	Rectifier (Moving-iron not allowed)	Maximum voltage difference between wires under 3%
Output Current $I_o$	(A4) (A5) (A6)	Moving-iron	Under the inverter rated current
Output power $P_o$	(W3) (W4)	Power-meter	$P_o=W3+W4$
Output power factor	$PF_o = \frac{P_o}{\sqrt{3}V_o \cdot I_o} \times 100\%$		

## Chapter 5 Options and accessories

### Class B EMI Filters

Filter model	Inverter model	Dimensions (mm) W x H x D	Current (A)
FT1000-0.4-S	SYN10 S 220 01 AF SYN10 S 220 03 AF	36x189x71	6.5
FT1000-0.75-S	SYN10 S 220 05 AF SYN10 S 220 07 AF	36x191x110	18
FT1000-2.2-S	SYN10 S 220 09 AF	41x191x174	29
FT1000-2.2-T	SYN10 T 400 05 AF SYN10 T 400 07 AF SYN10 T 400 09 AF	41X191X110	10

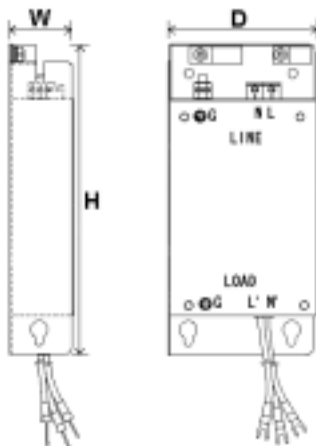

Book type mounting class B EMI filter upon the main plate

### DIN RAIL Specification

Model	Dimension (mm)	Inverter model
DIN E2-201	130 x 72 x 7.5	All SYN10 models

### Braking resistor selection

INVERTER MODEL	Braking module	Braking resistor	Resistor model
SYN10 S 220 01 AF	—	—	—
SYN10 S 220 03 AF	—	—	—
SYN10 S 220 05 AF	—	—	—
SYN10 S 220 07 AF	○	X	SR-0.75-S
SYN10 S 220 09 AF	○	X	SR-0.75-S
SYN10 T 400 05 AF	○	X	SR-0.75-T
SYN10 T 400 07 AF	○	X	SR-1.5-T
SYN10 T 400 09 AF	○	X	SR-2.2-T

○: Built-in

X: External

—: Not available

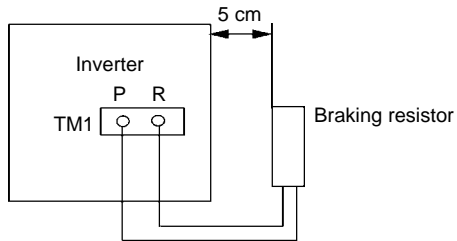

## Braking resistor features

Inverter model	Resistor type	Rated data	Maximum braking torque $M_{max}$
SYN10 S 220 07 AF ...	SR-0.75-S	100 $\Omega$ 150 W	85 % $t_{on}=10s, \delta=10\%$
SYN10 S 220 09 AF ...	SR-0.75-S	100 $\Omega$ 150 W	60 % $t_{on}=10s, \delta=10\%$
SYN10 T 400 05 AF ...	SR-0.75-T	300 $\Omega$ 150 W	150 % $t_{on}=11.5s, \delta=11.5\%$
SYN10 T 400 07 AF ...	SR-1.5-T	100 $\Omega$ 150 W	150 % $t_{on}=10.7s, \delta=10.7\%$
SYN10 T 400 09 AF ...	SR-2.2-T	150 $\Omega$ 300 W	150 % $t_{on}=8s, \delta=8\%$

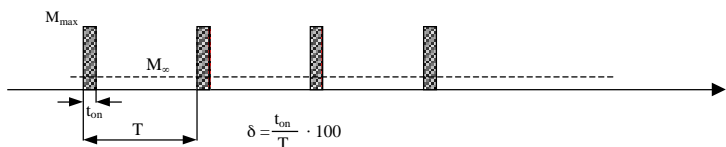

## Altitude derating:

Altitude (Meter)	Rated current percentage
1.000	100
1.200	99
1.500	99
1.800	98
2.100	98
2.400	97
2.700	96
3.000	96
3.600	95
4.300	93
4.900	92
5.500	91
6.100	90

## PARAMETERS TABLE

CUSTOMER				MODEL	
APPLICATION				TELEPHONE	
ADDRESS					
F_ ##	Value Setting	F_ ##	Value Setting	F_ ##	Value Setting
F_00		F_11		F_22	
F_01		F_12		F_23	
F_02		F_13		F_24	
F_03		F_14		F_25	
F_04		F_15		F_26	
F_05		F_16		F_27	
F_06		F_17		F_28	
F_07		F_18		F_29	
F_08		F_19		F_30	
F_09		F_20			
F_10		F_21			

**SEDE CENTRALE - HEADQUARTERS**

**BONFIGLIOLI RIDUTTORI S.p.A.**  
Via Giovanni XXIII, 7/A  
40012 Lippo di Calderara di Reno - Bologna (ITALY)  
Tel. (+39) 051 6473111  
Fax (+39) 051 6473126  
www.bonfiglioli.com  
bonfiglioli@bonfiglioli.com

**SALES DEPARTMENT****INDUSTRIAL TRANSMISSION & AUTOMATION DRIVES**

**BONFIGLIOLI RIDUTTORI S.p.A.**  
Via Giovanni XXIII, 7/A  
40012 Lippo di Calderara di Reno - Bologna (ITALY)  
Tel. (+39) 051 6473111 - Fax (+39) 051 6473126  
bonfiglioli@bonfiglioli.com

**SALES DEPARTMENT****MOBILE EQUIPMENT DRIVES**

**BONFIGLIOLI RIDUTTORI S.p.A.**  
Via Enrico Mattei, 12 - Z.I. Villa Selva - 47100 Forlì (ITALY)  
Tel. (+39) 0543 789111  
Fax (+39) 0543 789242 - 0543 789245  
trasmtila@bonfiglioli.com

**UFFICI VENDITE ITALIA - ITALY SALES OFFICES**

**PARMA** - Largo Luca Galzi, 9/E  
Tel. 0521 987275 - Fax 0521 987388

**DEPOSITI IN ITALIA - STOCK HOUSES IN ITALY**

**ASSAGO (MILANO)**  
Via Idiomani ang. Donizetti  
Tel. 02 48844710 / 02 4883395 - Fax 02 48844750 / 02 4883874

**TORINO** - Corso Susa, 242 - Palazzo Prisma 88 - 10098 Rivoli  
Tel. 011 9585116 - Fax 011 9587503

**PADOVA** - IX Strada, 1 - Zona Industriale  
Tel. 049 8070911 - Fax 049 8074033 / 049 8073883

**MILANO** - Via Idiomani ang. Donizetti - 20094 Assago - Milano  
Tel. 0245716930 - Fax 0245712745

**BONFIGLIOLI WORLDWIDE & BEST PARTNERS**

**AUSTRALIA**  
BONFIGLIOLI TRANSMISSION (Aust) Pty Ltd.  
48-50 Adderly St. (East) - Auburn (Sydney) N.S.W. 2144  
Tel. (+61) 2 9748 8955 - Fax (+61) 2 9748 8740  
P.O. Box 6705 Silverwater NSW 2128  
www.bonfiglioli.com.au - bta1@bonfiglioli.com.au

**BELGIUM** **BEST**  
N.V. ESCO TRANSMISSION S.A.  
Culliganlaan 3 - 1831 Machelem Diegem  
Tel. 0032 2 7204880 - Fax 0032 2 7212827  
Tlx 21930 Escopo B  
www.escotrans.be - info@escotrans.be

**CANADA**  
BONFIGLIOLI CANADA INC.  
2-7941 Jane Street - Concord, ONTARIO L4K 4L6  
Tel. (+1) 905 7384466 - Fax (+1) 905 7389833  
www.bnagear.com - sales@bnagear.com

**GREAT BRITAIN**  
BONFIGLIOLI (UK) LIMITED  
5 Grosvenor Grange - Woolston - Warrington  
Cheshire WA1 4SF  
Tel. (+44) 1925 852667 - Fax (+44) 1925 852668  
www.bonfiglioliuk.co.uk - sales@bonfiglioliuk.co.uk

**FRANCE**  
BONFIGLIOLI TRANSMISSIONS S.A.  
14 Rue Eugène Pottier BP 19 - Zone Industrielle de Moimont II  
95670 Marly la Ville - Tx: 688501 BONFI F  
Tel. (+33) 1 34474510 - Fax (+33) 1 34688800  
www.bonfiglioli.fr - bf@bonfiglioli.fr

**GERMANY**  
BONFIGLIOLI GETRIEBE GmbH  
Hamburger Straße 18 - 41540 Dormagen  
Tel. (+49) 2133 50260 - Fax (+49) 2133 502610  
www.bonfiglioli.de - bonfiglioli.getriebe@bonfiglioli.de

**VECTRON Elektronik GmbH**  
Europark Fichtenhain A 6 47807 Krefeld  
Tel. (+49) 2151 83960 - Fax (+49) 2151 839699  
www.vectron.net - info@vectron.net

**GREECE**  
BONFIGLIOLI HELLAS S.A.  
O.T. 48A, T.O. 230 - C.P. 570 22, Industrial Area - Thessaloniki  
Tel. (+30) 310 795456-7-8 - Fax (+30) 310 795903  
www.bonfiglioli.gr - bonfigr@otenet.gr

**HOLLAND** **BEST**  
ELECTRO STOCKVIS AANDRUSFTECHNIEK  
Loosterweg, 7 - 2215 TL Voorhout  
Tel. (+31) 252 219 123 - Fax (+31) 252 231 660  
www.elsto.nl - info@elsto.nl

**HUNGARY** **BEST**  
AGISYS AGITATORS & TRANSMISSIONS Ltd  
Fehérvári u. 98 - 1116 Budapest  
Tel. 0036 1 2061 477 - Fax 0036 1 2061 486  
www.agisys.uk - info@agisys.uk

**INDIA**  
BONFIGLIOLI TRANSMISSIONS PVT Ltd.  
PLOT AC7-AC11 Sidco Industrial Estate  
Thirumudakkam - Chennai 600 044  
Tel. +91(0)44 4781035 / 4781036 / 4781037  
Fax +91(0)44 4780091 / 4781904 - bonfig@vsnl.com

**POLAND** **BEST**  
POLPACK Sp. z o.o. - Ul. Chrobrego 135/137 - 87100 Torun  
Tel. 0048.56.6559235 - 6559236 - Fax 0048.56.6559238  
www.polpack.com.pl - polpack@polpack.com.pl

**SPAIN**  
TECNOTRANS SABRE S.A.  
Pol. Ind. Zona Franca sector C, calle F, n°6 08040 Barcelona  
Tel. (+34) 93 4478400 - Fax (+34) 93 3360420  
www.tecnotrans.com - tecnotrans@tecnotrans.com

**SOUTH AFRICA**  
BONFIGLIOLI POWER TRANSMISSION Pty Ltd.  
55 Galaxy Avenue, Limbo Business Park - Sandton  
Tel. (+27) 11 608 2030 OR  
Fax (+27) 11 608 2631  
www.bonfiglioli.co.za  
bonfigsales@bonfiglioli.com

**SWEDEN**  
BONFIGLIOLI SKANDINAVIEN AB  
Kontorsgatan - 234 34 Lomma  
Tel. (+46) 40 412545 - Fax (+46) 40 414508  
www.bonfiglioli.se - info@bonfiglioli.se

**THAILAND** **BEST**  
K.P.T MACHINERY (1993) CO.LTD.  
259/83 Soi Phiboonves,  
Sukhumvit 71 Rd. Phrakonong-nur,  
Wattana Bangkok 10110  
Tel. 0066.2.3913030/7111998  
Fax: 0066.2.7112652/3811308/3814905  
www.kpt-group.com - sales@kpt-group.com

**USA**  
BONFIGLIOLI USA INC  
1000 Worlwide Boulevard  
Hebron, KY 41048  
Tel. (+1) 859 334 3333 - Fax: (+1) 859 334 8888  
www.bonfiglioliusa.com  
industrialisales@bonfiglioliusa.com  
mobilesales@bonfiglioliusa.com

**VENEZUELA** **BEST**  
MACUINARIA Y ACCESORIOS IND.-C.A.  
Calle 3B - Edif. Comindu - Planta Baja - Local B  
La Urbina - Caracas 1070  
Tel. 0058.212.2413570 / 2425268 / 2418263  
Fax: 0058.212.2424552 - Tx: 24780 Maica V  
www.maica-ve.com - maica@telcel.net.ve