

Paragrafo Heading Abschnitt Paragraphe	Descrizione	Description	Beschreibung	Description	
	<b>Istruzioni di sicurezza</b>	<b>Safety instructions</b>	<b>Sicherheitsanweisungen</b>	<b>Instruction de sécurité</b>	2
1.0	Identificazione	Identification	Identifikation	Identification	2
2.0	Richiesta ricambi	Spare parts order	Bestellung von Ersatzteilen	Demande de pièces détachées	2
3.0	Layout generale	General layout	Allgemeines Layout	Schéma d'implantation	3
4.0	Modulo C	Module C	Baueinheit C	Module C	4
5.0	Modulo S	Module S	Baueinheit S	Module S	10
6.0	Modulo A	Module A	Baueinheit A	Module A	12
7.0	Modulo F	Module F	Baueinheit F	Module F	20
8.0	Modulo addizionale	Additional gear module	Zusätzliche Baueinheit	Module additionnel	26
9.0	Moduli entrata	Input modules	Antriebseinheit	Modules entrée	30
10.0	Motori elettrici	Electric motors	Elektromotoren	Moteurs électriques	36
11.0	Lubrificazione	Lubrication	Schmierung	Lubrification	49
12.0	Informazioni generali riduttori	General information on gearboxes	Allgemeine Informationen über die Getriebe	Informations générales sur les réducteurs	63
13.0	Informazioni generali motori elettrici	General information: electric motors	Allgemeine Informationen über die Elektromotoren	Informations générales moteurs électriques	69



Leggere attentamente



Read carefully



Aufmerksam lesen



Lire attentivement



Rischio di folgorazione



Electrical hazard



Fulgurationsgefahr



Risque d'électrocution

#### Revisionsi

L'indice di revisione del catalogo è riportato a pag. 80.

Al sito [www.bonfiglioli.com](http://www.bonfiglioli.com) sono disponibili i cataloghi con le revisioni aggiornate.

#### Revisions

Refer to page 80 for the catalogue revision index.

Visit [www.bonfiglioli.com](http://www.bonfiglioli.com) to search for catalogues with latest revision index.

#### Änderungen

Das Revisionsverzeichnis des Katalogs wird auf Seite 80 wiedergegeben. Auf unserer Website [www.bonfiglioli.com](http://www.bonfiglioli.com) werden die Kataloge in ihrer letzten, überarbeiteten Version angeboten.

#### Révisions

Le sommaire de révision du catalogue est indiqué à la page 80.

Sur le site des catalogues avec les dernières révisions sont disponibles.

**ISTRUZIONI DI SICUREZZA**



Le seguenti istruzioni di sicurezza fanno riferimento in via principale all'utilizzo di motoriduttori. Tenere in considerazione le istruzioni di sicurezza supplementari riportate nelle singole sezioni di questo manuale istruzioni. I conduttori di tensione e gli organi in movimento di macchine elettriche possono provocare gravi lesioni o la morte. L'installazione, il collegamento e la messa in funzione, unitamente agli interventi di manutenzione e riparazione, devono essere effettuati esclusivamente da personale specializzato tenendo in considerazione quanto di seguito riportato:

- le presenti istruzioni
- i segnali di avvertimento e le etichette istruzioni sull'unità motore/riduttore
- tutte le documentazioni di progettazione, le istruzioni di messa in funzione e gli schemi tecnici
- le regolamentazioni e i requisiti specifici del sistema
- le normative nazionali/regionali vigenti (normative di sicurezza/antifortunistiche)

**Uso previsto**

Questi motori elettrici sono destinati all'uso in sistemi industriali. Essi sono conformi alle normative e alle regolamentazioni vigenti e rispettano le disposizioni della Direttiva Bassa Tensione 73/23/CEE. I dati tecnici, come pure le condizioni ammesse sul luogo, sono indicati sulla targhetta identificativa della macchina e nel presente manuale istruzioni. Le informazioni ivi riportate devono essere rispettate!

**1.0 IDENTIFICAZIONE**

Tutti i riduttori, motoriduttori e motori sono muniti di una targhetta dalla quale potranno essere rilevati i dati necessari alla loro identificazione. Nella tabella sono indicate le tre tipologie di targhe di identificazione utilizzate per le varie configurazioni.

**SAFETY INSTRUCTIONS**



The following safety instructions relate primarily to the use of geared motors. Please consider the additional safety instructions in the individual sections of these operating instructions. Voltage conductors and movable parts of electrical machines can cause serious or fatal injury. Installation, connection, commissioning as well as maintenance and repair work may only be carried out by qualified specialists, taking into account:

- these instructions
- the warning and instructions labels on the motor / gear unit
- all other project planning documentation, commissioning instructions and schematic diagrams
- the system specific regulations and requirements
- the current national/regional regulations (safety/accident prevention regulations)

**Intended use**

These electrical motors are intended for industrial systems. They conform to the valid standards and regulations and meet the requirements of the Low Voltage Directive 73/23/EEC. Technical data as well as permitted conditions on site can be found on the nameplate and in these operating instructions. These details must be observed!

**1.0 IDENTIFICATION**

All gearboxes, gearmotors, and motors carry a nameplate with data to be used for their identification. Table shows the three types of nameplates used for the various configurations.

**SICHERHEITSANWEISUNGEN**



Die nachstehenden Sicherheitsanweisungen beziehen sich hauptsächlich auf den Einsatz der Getriebemotoren. Dabei sind jedoch auch die zusätzlichen, in den einzelnen Abschnitten dieses Anleithandbuchs enthaltenen Sicherheitsanweisungen zu berücksichtigen. Die Spannungsleiter und die sich in Bewegung befindlichen Organe an elektrischen Maschinen können schwere Verletzungen verursachen oder gar tödliche Gefahren in sich bergen. Die Installation, der Anschluss und die Inbetriebsetzung, ebenso wie die Instandhaltungs- und Reparatureingriffe, dürfen ausschließlich nur von Fachpersonal durchgeführt werden, dass folgendes berücksichtigen muss:

- die vorliegenden Anleitungen
- die Warnhinweise und die Angaben auf den an der Einheit Motor/Getriebe angebrachten Anweisungsetiketten
- alle Projektdokumente, die Anleitungen für die Inbetriebsetzung und die technischen Pläne
- die spezifischen Regeln und Anforderungen des Systems
- die sich in Kraft befindlichen nationalen/regionalen Richtlinien (Sicherheits-/Unfallschutznormen)

**Vorgesehener Einsatz**

Diese Elektromotoren sind für den Einsatz an industriellen Systemen bestimmt. Sie entsprechen den gültigen Richtlinien und Regelungen und der Niederspannungsrichtlinie EWG/73/23. Die technischen Daten, ebenso wie die zulässigen Bedingungen vor Ort, werden auf den Typenschild der Maschine und in der vorliegenden Anleitung angegeben. Die hier enthaltenen Informationen müssen eingehalten werden!

**1.0 IDENTIFIKATION**

Alle Getriebe, Getriebemotoren und Motoren sind mit einem Namensschild ausgerüstet, auf dem die technischen Daten, die für ihre Identifikation ausschlaggebend sind, abgelesen werden können. In der Tabelle sind die drei Schildertypen aufgeführt, die zur Identifikation der verschiedenen Konfigurationen dienen.

**INSTRUCTION DE SÉCURITÉ**



Les instructions de sécurité suivantes se réfèrent principalement à l'utilisation des motoréducteurs.

Considérer les instructions de sécurité supplémentaires indiquées dans les chapitres de ce manuel d'instructions. Les conducteurs de tension et les organes en mouvement des machines électriques peuvent provoquer de graves lésions, voire même être mortels. L'installation, le branchement et la mise en service, ainsi que les interventions d'entretien et de réparation, doivent être effectués exclusivement par du personnel qualifié, dans le respect des indications suivantes:

- les présentes instructions
- les signaux d'avertissement et les autocollants d'instructions présents sur l'unité moteur/réducteur
- tous les documents de conception, les instructions de mise en service et les schémas techniques
- les réglementations et les conditions requises spécifiques du système
- les normes nationales/régionales en vigueur (normes de sécurité/de prévention des accidents)

**Utilisation prévue**

Ces moteurs électriques sont destinés à être utilisés dans des systèmes industriels. Ils sont conformes aux normes et réglementations en vigueur et respectent les dispositions de la Directive Basse Tension 73/23/CEE. Les caractéristiques techniques ainsi que les conditions admises sur le site sont indiquées sur la plaquette signalétique de la machine et dans ce manuel d'instructions. Il est indispensable de respecter les informations qui y sont indiquées !

**1.0 IDENTIFICATION**

Tous les réducteurs, motoréducteurs et moteurs sont munis d'une plaque sur laquelle figurent les données nécessaires à leur identification. Dans le tableau sont indiqués les trois types de plaques signalétiques utilisées pour les différentes configurations.

--	--	--

**2.0 RICHIESTA RICAMBI**

La tabella indica i dati che è indispensabile fornire in fase di richiesta ricambi per poter effettuare una corretta identificazione del prodotto e di conseguenza una sollecita risposta alla richiesta stessa. In funzione delle particolari tecniche di montaggio dei componenti utilizzate dalla BONFIGLIOLI RIDUTTORI si consiglia, dove previsto, l'acquisto dei kit di montaggio.

**2.0 SPARE PARTS ORDER**

Table indicates the data that must be supplied when placing a spare part order so that the product may be correctly identified and the order processed promptly. Due to the assembly techniques for components used by BONFIGLIOLI RIDUTTORI to optimise the performance of gearboxes and gearmotors, we recommend the purchase (where applicable) of the mounting kits.

**2.0 BESTELLUNG VON ERSATZTEILEN**

In der Tabelle sind die Daten aufgelistet, die bei der Bestellung von Ersatzteilen unbedingt angegeben werden müssen, damit die Teile richtig identifiziert werden und die Bestellung schneller erfolgen kann. Weggens speziellen Montagetechniken der Komponenten, die bei BONFIGLIOLI RIDUTTORI angewendet werden und die zu einer Verbesserung der Leistungen der Getriebe und Getriebemotoren führen, empfehlen wir, wenn möglich die Ausrüstungselemente zu kaufen.

**2.0 DEMANDE DE PIÈCES DÉTACHÉES**

Le tableau indique les données qu'il est indispensable de fournir pour toute commande de pièces détachées, ceci pour permettre l'identification correcte du produit et, par conséquent, une livraison dans les meilleurs délais. Du fait des techniques particulières de montage des composants utilisées par BONFIGLIOLI RIDUTTORI à même d'optimiser les performances de réducteurs et motoréducteurs, nous vous conseillons dans la mesure du possible l'achat des kits.

Identificazione prodotto		Product information		Produktbeschreibung		Identification produit	
Type/Mot. : _____		Nr./Code : _____		Nr./Code : _____		Nr./Code : _____	
Batch/N° : _____		Nm : _____		Nm : _____		Nm : _____	
Identificazione parti		Parts identification		Beschreibung der Teile		Identification des composants	
N.	Denominazione / Description / Benennung / Dénomination					Q.tà / Q.ty / Menge / Q.té	

BONFIGLIOLI RIDUTTORI S.p.A. si riserva il diritto di richiedere ulteriori informazioni sul prodotto.

BONFIGLIOLI RIDUTTORI S.p.A. reserves the rights to require further information on the product itself.

BONFIGLIOLI RIDUTTORI S.p.A. beinhaltet das Recht, weitere Informationen über das Produkt zu erfragen.

BONFIGLIOLI RIDUTTORI S.p.A. se réserve le droit pour tout autre renseignement sur le produit.

### 3.0 LAYOUT GENERALE

La tabella sottostante illustra lo schema generale di collegamento dei vari moduli con l'indicazione dei paragrafi in cui sono riportate le sezioni e le liste dei componenti.

### 3.0 GENERAL LAYOUT

Table below shows the general layout for the various modules and indicates the paragraphs in which the cross-sectional drawings and parts lists are given.

### 3.0 ALLGEMEINES LAYOUT

Die Tabelle zeigt das Gesamtschema zum Zusammenbau der verschiedenen Baueinheiten und weist auf die Abschnitte, in denen die einzelnen Untergruppen und Komponentenlisten aufgeführt sind.

### 3.0 SCHEMA D'IMPLANTATION

Le tableau présente le schéma général d'accouplement des différents modules, avec l'indication des paragraphes où sont fournies les sections et les nomenclatures des composants.

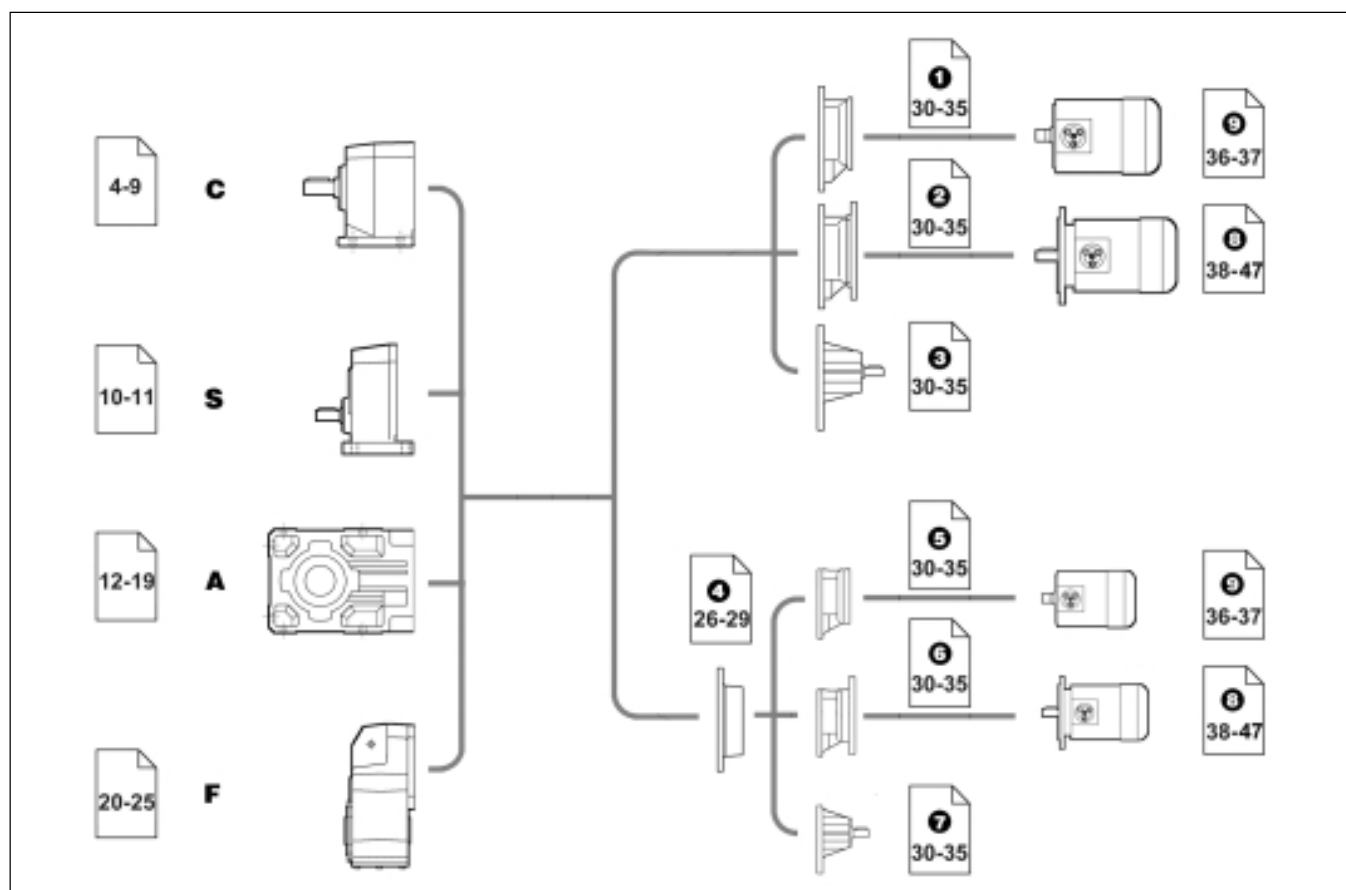

Legenda:

C Modulo uscita C  
S Modulo uscita S  
A Modulo uscita A  
F Modulo uscita F

① Modulo S (2 stadi)  
② Modulo P (IEC) (2 stadi)  
③ Modulo HS (2 stadi)  
④ Modulo addizionale (3 stadi)  
⑤ Modulo S (3 stadi)  
⑥ Modulo P (IEC) (3 stadi)  
⑦ Modulo HS (3 stadi)  
⑧ Motore IEC  
⑨ Motore M

Key:

C Output module C  
S Output module S  
A Output module A  
F Output module F

① S Module (2 stages)  
② P Module (IEC) (2 stages)  
③ HS module (2 stages)  
④ Additional module (3 stages)  
⑤ Module S (3 stages)  
⑥ P Module (IEC) (3 stages)  
⑦ HS module (3 stages)  
⑧ IEC motor  
⑨ M motor

Zeichenerklärung:

C Abtriebseinheit C  
S Abtriebseinheit S  
A Abtriebseinheit A  
F Abtriebseinheit F

① S Baueinheit (2 Stufen)  
② P Baueinheit (IEC) (2 Stufen)  
③ HS Baueinheit (2 Stufen)  
④ Zusatzbaueinheit (3 Stufen)  
⑤ S Baueinheit (3 Stufen)  
⑥ P Baueinheit (IEC) (3 Stufen)  
⑦ HS Baueinheit (3 Stufen)  
⑧ IEC Motor  
⑨ M Motor

Legende:

C Module de sortie C  
S Module de sortie S  
A Module de sortie A  
F Module de sortie F

① Module S (2 étages)  
② Module P (IEC) (2 étages)  
③ Module HS (2 étages)  
④ Module addizionale (3 étages)  
⑤ Module S (3 étages)  
⑥ Module P (IEC) (3 étages)  
⑦ Module HS (3 étages)  
⑧ Moteur normalisé CEI  
⑨ Moteur M

### C10 ... C60

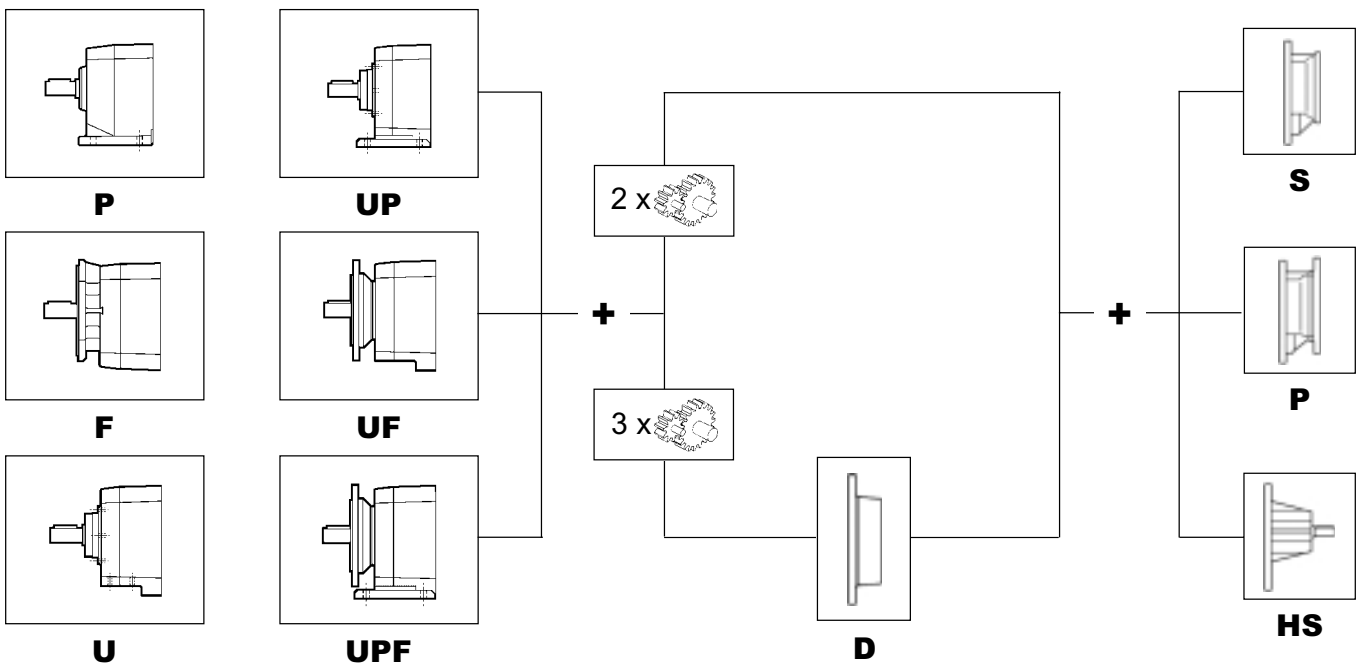
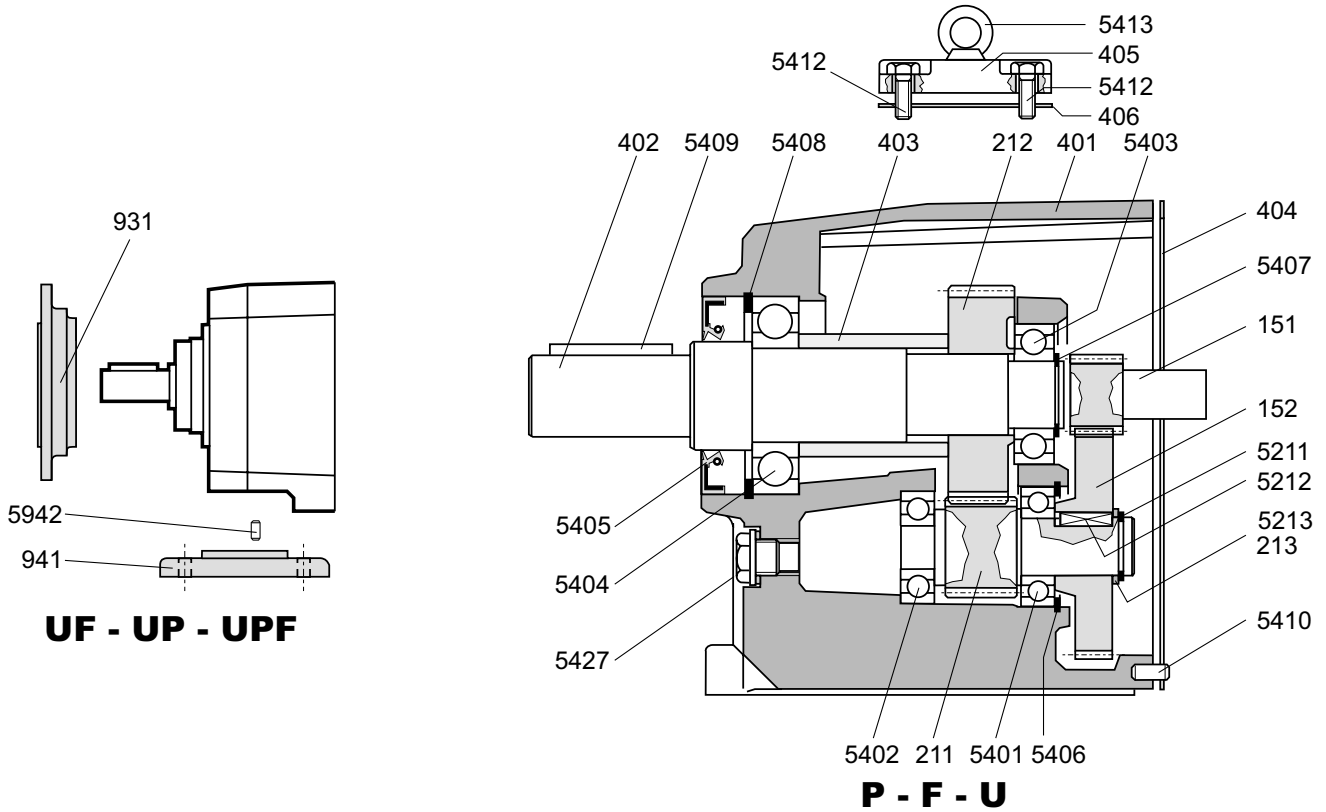

C_	ref.	<b>P - F - U - UP - UF - UPF</b>			
<b>10 - 20 - 30</b> <b>40 - 50 - 60</b>	151	Pignone 1ª riduzione	<i>1<sup>st</sup> red. pinion</i>	Ritzel 1. Stufe	<i>Pignon 1<sup>ère</sup> réd.</i>
	152	Corona 1ª riduzione	<i>1<sup>st</sup> red. gearwheel</i>	Zahnrad 1. Stufe	<i>Couronne 1<sup>ère</sup> réd.</i>
	211	Pignone lento	<i>Pinion shaft</i>	Abtriebsritzel	<i>Pignon à la sortie</i>
	212	Corona lenta	<i>Gear</i>	Abtriebszahnrad	<i>Couronne à la sortie</i>
	401	Cassa	<i>Gear case</i>	Gehäuse	<i>Carter</i>
	402	Albero lento	<i>Output shaft</i>	Abtriebswelle	<i>Arbre de sortie</i>
	403	Distanziale	<i>Spacer</i>	Distanzring	<i>Entretoise</i>
	404	Guarnizione	<i>Gasket</i>	Dichtung	<i>Joint</i>
	5211	Anello seeger	<i>Circlip</i>	Seegerring	<i>Seeger</i>
	5212	Linguetta	<i>Key</i>	Paßteder	<i>Clavette</i>
	5401	Cuscinetto	<i>Bearing</i>	Kugellager	<i>Roulement</i>
	5402	Cuscinetto	<i>Bearing</i>	Kugellager	<i>Roulement</i>
	5403	Cuscinetto	<i>Bearing</i>	Kugellager	<i>Roulement</i>
	5404	Cuscinetto	<i>Bearing</i>	Kugellager	<i>Roulement</i>
	5405	Anello di tenuta	<i>Seal ring</i>	Simmerring	<i>Bague d'étanchéité</i>
	5406	Anello seeger	<i>Circlip</i>	Seegerring	<i>Seeger</i>
	5407	Anello seeger	<i>Circlip</i>	Seegerring	<i>Seeger</i>
5408	Anello seeger	<i>Circlip</i>	Seegerring	<i>Seeger</i>	
5409	Linguetta	<i>Key</i>	Paßteder	<i>Clavette</i>	
5410	Spina cilindrica	<i>Dowel pin</i>	Zylinderstift	<i>Goupille cylindrique</i>	
<b>20 - 30</b>	213	Ralla pignone lento	<i>Washer</i>	Scheibe des Abtriebsritzel	<i>Butée pignon à la sortie</i>
<b>40</b>	5213	Ralla pignone lento	<i>Washer</i>	Scheibe des Abtriebsritzel	<i>Butée pignon à la sortie</i>
<b>60</b>	405	Coperchio ispezione	<i>Inspection cover</i>	Inspektionsdeckel	<i>Couvercle d'inspection</i>
	406	Guarnizione	<i>Gasket</i>	Dichtung	<i>Joint</i>
	5412	Vite di fissaggio	<i>Fixing screw</i>	Befestigungsschraube	<i>Vis de fixation</i>
	5413	Golfare	<i>Eyebolt</i>	Ösenschraube	<i>Cheville à oeil</i>
	5427	Tappo olio	<i>Oil plug</i>	Ölverschluß	<i>Bouchon d'huile</i>
<b>UF - UPF</b>					
<b>10 - 20 - 30</b> <b>40 - 50 - 60</b>	931	Flangia	<i>Bolted flange</i>	Flansch	<i>Bride</i>
<b>UP - UPF</b>					
<b>10 - 20 - 30</b> <b>40 - 50 - 60</b>	941	Piedi riportati	<i>Bolted flange</i>	Eingesetzte Füße	<i>Pattes rapportées</i>
	5942	Spina cilindrica piede	<i>Dowel pin</i>	Zylinderstift des Fußes	<i>Goupille cylindrique patte</i>

**C702 - C802**

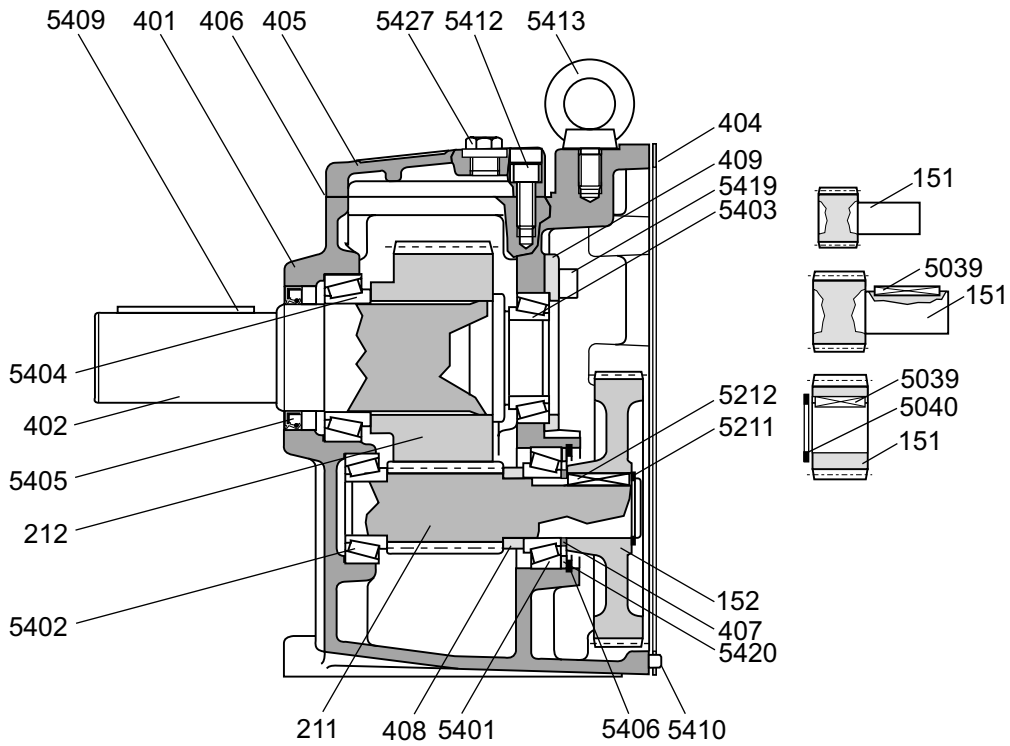

**C703 - C803  
C704 - C804**

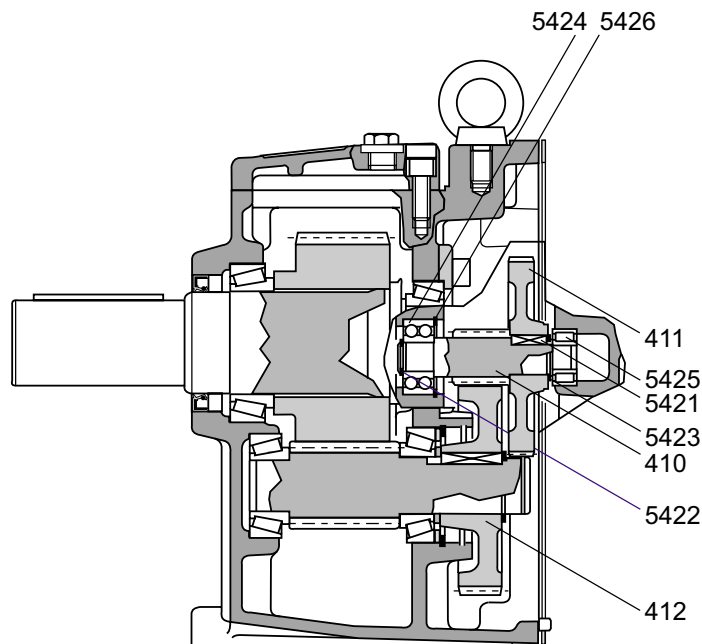

C_	ref.				
<b>702 - 802 703 - 803 704 - 804</b>	151	Pignone 1ª riduzione	1 <sup>st</sup> red. pinion	Ritzel 1. Stufe	Pignon 1 <sup>ère</sup> réd.
	211	Pignone lento	Pinion shaft	Abtriebsritzel	Pignon à la sortie
	212	Corona lenta	Gear	Abtriebszahnrad	Couronne à la sortie
	401	Cassa	Gear case	Gehäuse	Carter
	402	Albero lento	Output shaft	Abtriebswelle	Arbre de sortie
	404	Guarnizione	Gasket	Dichtung	Joint
	405	Coperchio ispezione	Inspection cover	Inspektionsdeckel	Couvercle d'inspection
	406	Guarnizione	Gasket	Dichtung	Joint
	407	Distanziale	Spacer ring	Distanzring	Entretoise
	5211	Anello seeger	Circlip	Seegerring	Seeger
	5212	Linguetta	Key	Paßfeder	Clavette
	5401	Cuscinetto	Bearing	Kugellager	Roulement
	5402	Cuscinetto	Bearing	Kugellager	Roulement
	5403	Cuscinetto	Bearing	Kugellager	Roulement
	5404	Cuscinetto	Bearing	Kugellager	Roulement
	5405	Anello di tenuta	Seal ring	Simmerring	Bague d'étanchéité
	5406	Anello seeger	Circlip	Seegerring	Seeger
	5409	Linguetta	Key	Paßfeder	Clavette
	5410	Spina cilindrica	Dowel pin	Zylinderstift	Goupille cylindrique
	5413	Golfare	Eyebolt	Ösenschraube	Cheville à oeillet
	5419	Vite di fissaggio	Fixing screw	Befestigungsschraube	Vis de fixation
	5420	Ralla pignone lento	Washer	Scheibe des Abtriebsritzel	Butée pignon à la sortie
	5427	Tappo olio	Oil plug	Ölverschluß	Bouchon d'huile
5039	Linguetta	Key	Paßfeder	Clavette	
5040	Anello seeger	Circlip	Seegerring	Seeger	
<b>702 - 802</b>	152	Corona 1ª riduzione	1 <sup>st</sup> red. gearwheel	Zahnrad 1. Stufe	Couronne 1 <sup>ère</sup> réd.
	408	Distanziale	Spacer ring	Distanzring	Entretoise
<b>702 - 802 703 - 803</b>	409	Anello per cuscinetto	Bearing ring	Ring für Lager	Bague pour roulement
	5412	Vite di fissaggio	Fixing screw	Befestigungsschraube	Vis de fixation
<b>703 - 803 704 - 804</b>	410	Pignone	Pinion	Ritzel	Pignon
	411	Corona	Gear	Zahnrad	Couronne
	412	Corona	Gear	Zahnrad	Couronne
	5421	Linguetta	Key	Paßfeder	Clavette
	5422	Seeger	Circlip	Seegerring	Seeger
	5423	Seeger	Circlip	Seegerring	Seeger
	5424	Cuscinetto	Bearing	Kugellager	Roulement
	5425	Cuscinetto	Bearing	Kugellager	Roulement
5426	Seeger	Circlip	Seegerring	Seeger	

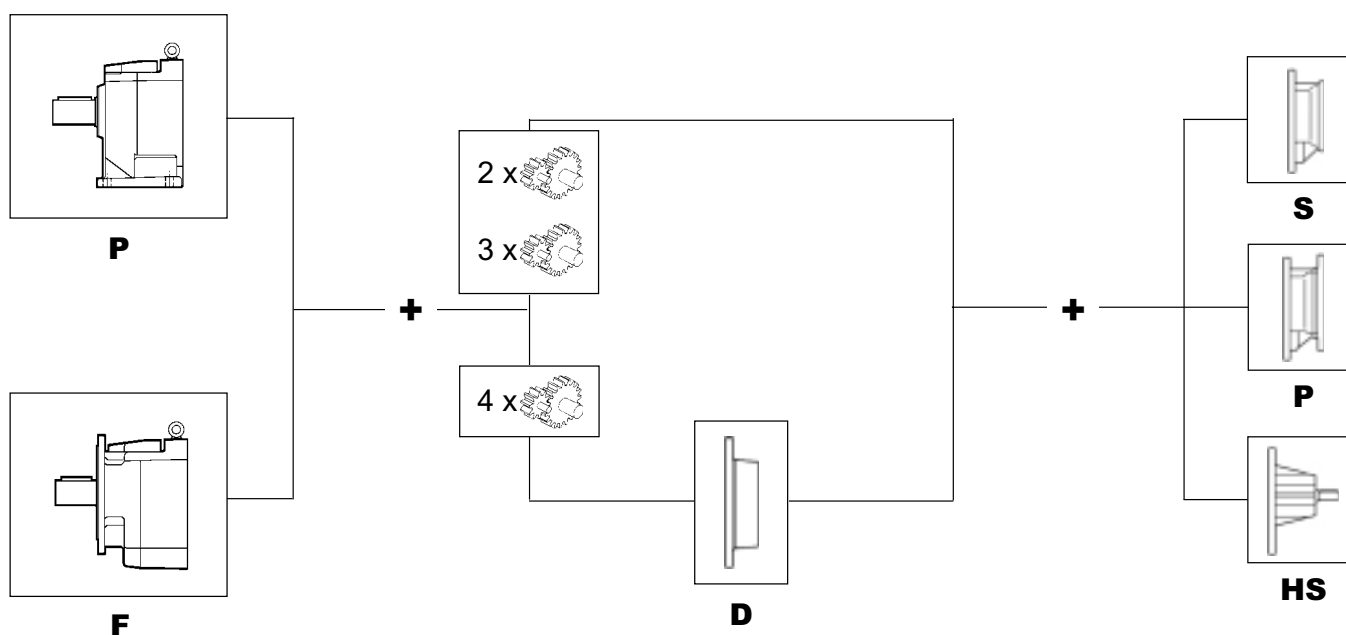

**C902 - C1002**

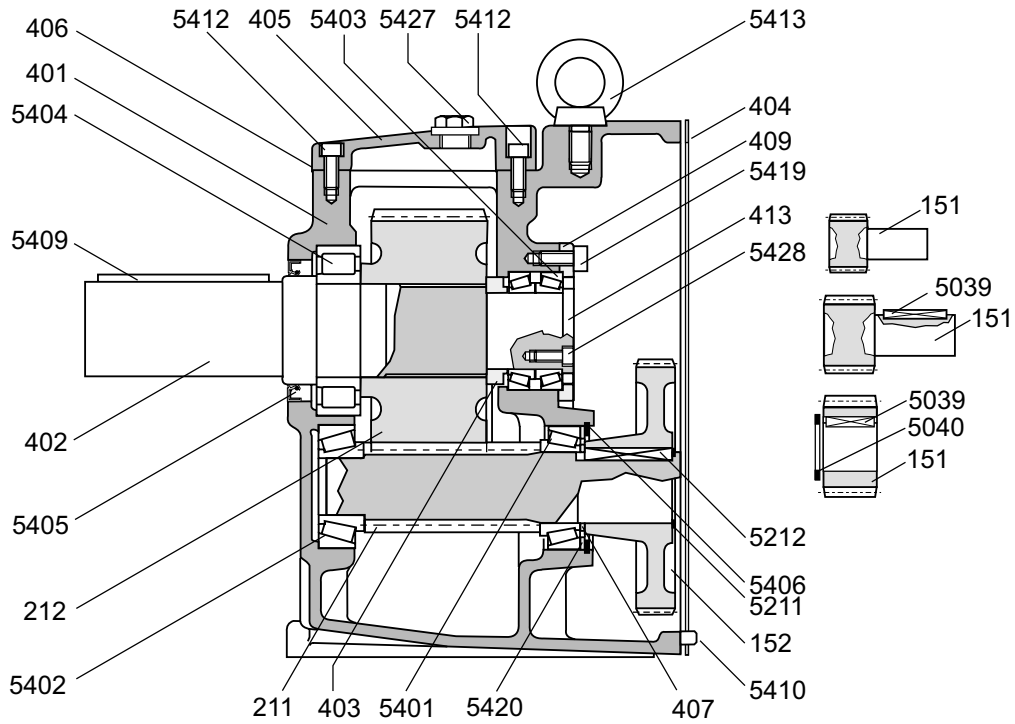

**C903 - C1003  
C904 - C1004**

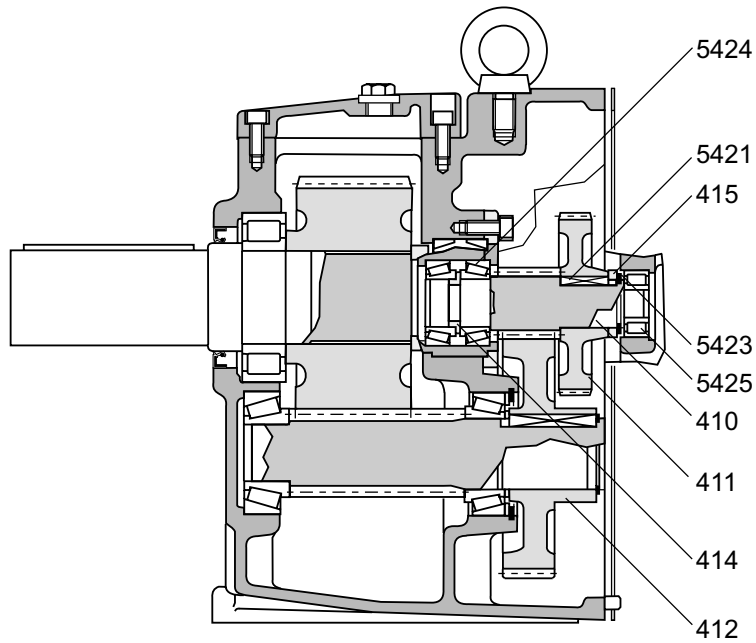

C_	ref.				
<b>902 - 1002 903 - 1003 904 - 1004</b>	151	Pignone 1ª riduzione	1 <sup>st</sup> red. pinion	Ritzel 1. Stufe	Pignon 1 <sup>ère</sup> red.
	211	Pignone lento	Pinion shaft	Abtriebsritzel	Pignon à la sortie
	212	Corona lenta	Gear	Abtriebszahnrad	Couronne à la sortie
	401	Cassa	Gear housing	Gehäuse	Carter
	402	Albero lento	Output shaft	Abtriebswelle	Arbre de sortie
	403	Distanziale	Spacer ring	Distanzring	Entretoise
	404	Guarnizione	Gasket	Dichtung	Joint
	405	Coperchio ispezione	Inspection cover	Inspektionsdeckel	Couvercle d'inspection
	406	Guarnizione	Gasket	Dichtung	Joint
	407	Distanziale	Spacer ring	Distanzring	Entretoise
	413	Rondella	Washer	Unterlegscheibe	Rondelle
	5211	Anello seeger	Circlip	Seegerring	Seeger
	5212	Linguetta	Key	Paßfeder	Clavette
	5401	Cuscinetto	Bearing	Kugellager	Roulement
	5402	Cuscinetto	Bearing	Kugellager	Roulement
	5403	Cuscinetto	Bearing	Kugellager	Roulement
	5404	Cuscinetto	Bearing	Kugellager	Roulement
	5405	Anello di tenuta	Oil seal	Simmerring	Bague d'étanchéité
	5406	Anello seeger	Circlip	Seegerring	Seeger
	5409	Linguetta	Key	Paßfeder	Clavette
	5410	Spina cilindrica	Dowel pin	Zylinderstift	Goupille cylindrique
	5412	Vite di fissaggio	Fixing screw	Befestigungsschraube	Vis de fixation
	5413	Golfare	Eyebolt	Ösenschraube	Cheville à oeillet
	5420	Ralla pignone lento	Washer	Scheibe des Abtriebsritzel	Butée pignon à la sortie
	5427	Tappo olio	Oil plug	Ölverschluß	Bouchon d'huile
	5428	Vite di fissaggio	Fixing screw	Befestigungsschraube	Vis de fixation
5039	Linguetta	Key	Paßfeder	Clavette	
5040	Anello seeger	Circlip	Seegerring	Seeger	
<b>902 - 1002</b>	152	Corona 1ª riduzione	1 <sup>st</sup> red. gear	Zahnrad 1. Stufe	Couronne 1 <sup>ère</sup> red.
<b>902 - 1002 903 - 1003</b>	409	Anello per cuscinetto	Bearing ring	Ring für Lager	Bague pour roulement
<b>903 - 1003 904 - 1004</b>	5419	Vite di fissaggio	Fixing screw	Befestigungsschraube	Vis de fixation
<b>903 - 1003 904 - 1004</b>	410	Pignone	Pinion	Ritzel	Pignon
	411	Corona	Gear	Zahnrad	Couronne
	412	Corona	Gear	Zahnrad	Couronne
	414	Boccola	Bushing	Buchse	Douille
	415	Distanziale	Spacer ring	Distanzring	Entretoise
	5421	Linguetta	Key	Paßfeder	Clavette
	5423	Seeger	Circlip	Seegerring	Seeger
	5424	Cuscinetto	Bearing	Kugellager	Roulement
	5425	Cuscinetto	Bearing	Kugellager	Roulement

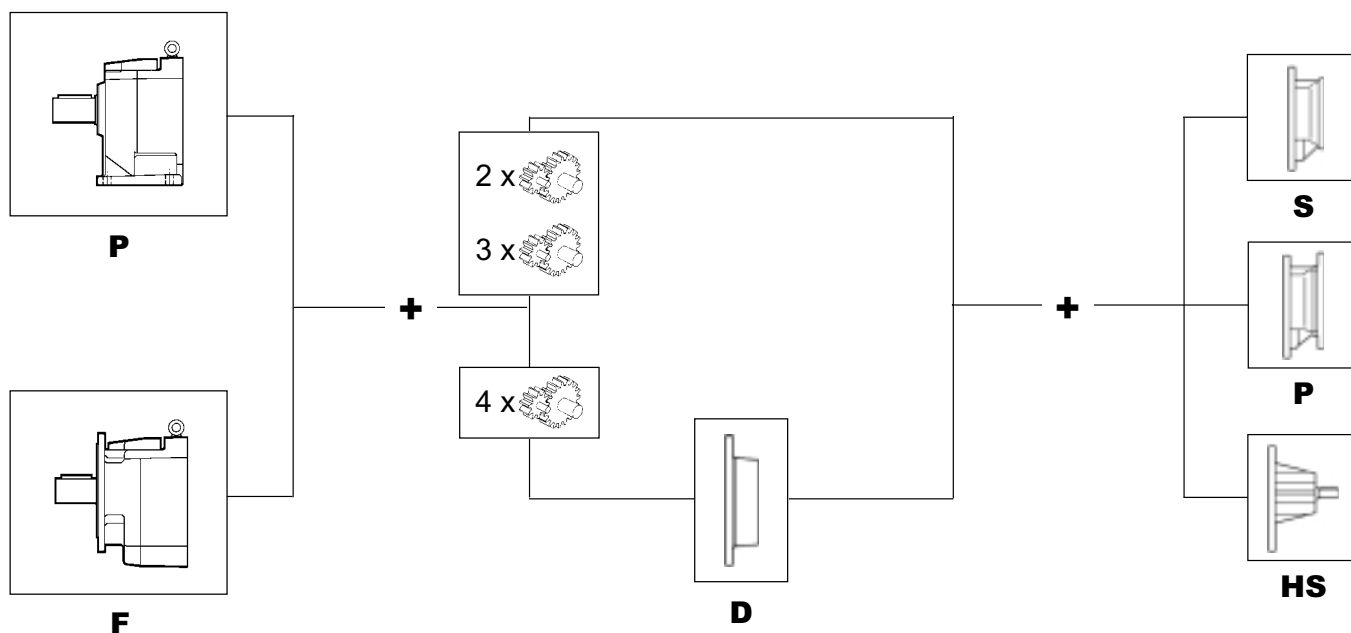

## S101 ... S501

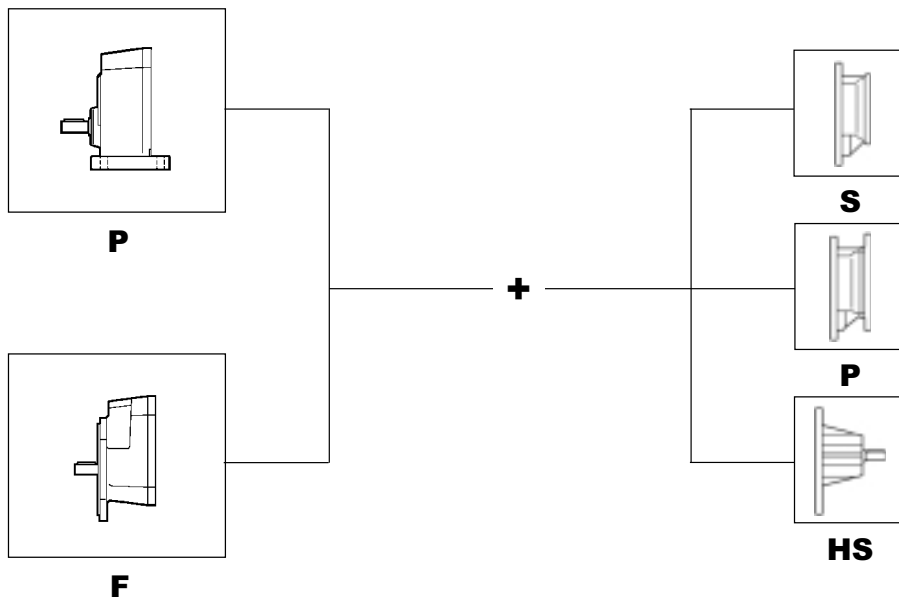
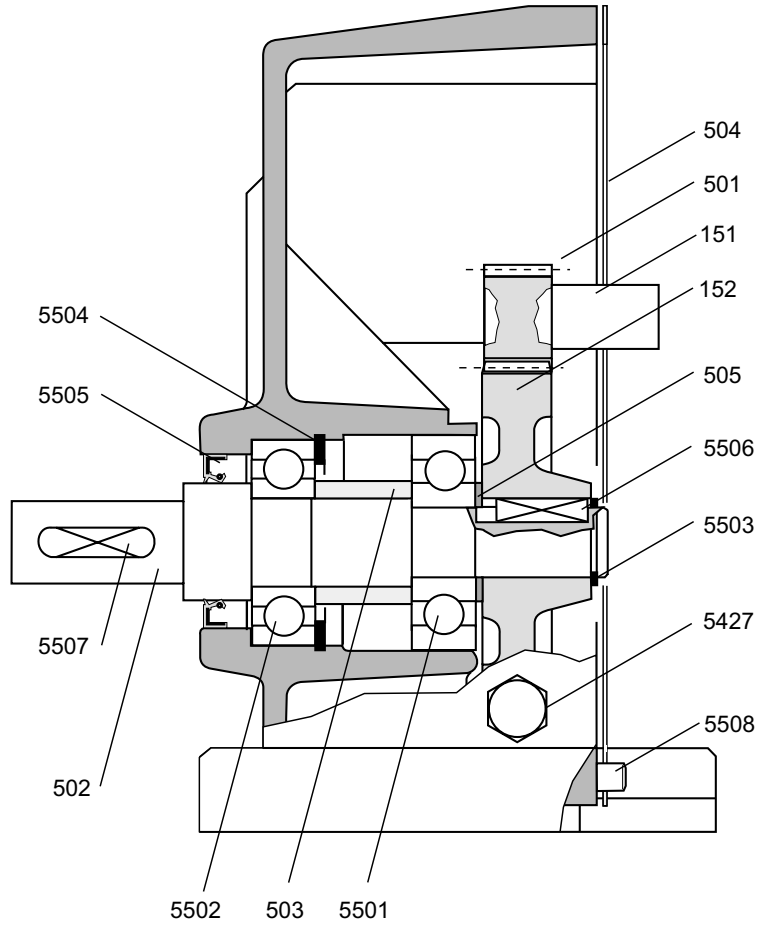

<b>S_</b>	ref.				
<b>101 - 501</b>	151	Pignone 1 <sup>a</sup> riduzione	<i>Pinion shaft</i>	Ritzel 1. Stufe	<i>Pignon 1<sup>ère</sup> réd.</i>
	152	Corona 1 <sup>a</sup> riduzione	<i>Gear</i>	Zahnrad 1. Stufe	<i>Couronne 1<sup>ère</sup> réd.</i>
	501	Cassa	<i>Gear case</i>	Gehäuse	<i>Carter</i>
	502	Albero lento	<i>Output shaft</i>	Abtriebswelle	<i>Arbre de sortie</i>
	503	Distanziale	<i>Spacer ring</i>	Distanzring	<i>Entretoise</i>
	504	Guarnizione	<i>Gasket</i>	Dichtung	<i>Joint</i>
	505	Distanziale	<i>Spacer ring</i>	Distanzring	<i>Entretoise</i>
	5501	Cuscinetto	<i>Bearing</i>	Kugellager	<i>Roulement</i>
	5502	Cuscinetto	<i>Bearing</i>	Kugellager	<i>Roulement</i>
	5503	Anello seeger	<i>Circlip</i>	Seegerring	<i>Seeger</i>
	5504	Anello seeger	<i>Circlip</i>	Seegerring	<i>Seeger</i>
	5505	Anello di tenuta	<i>Oil seal</i>	Simmerring	<i>Bague d'étanchéité</i>
	5506	Linguetta	<i>Key</i>	Paßteder	<i>Clavette</i>
	5507	Linguetta	<i>Key</i>	Paßfeder	<i>Clavette</i>
5508	Spina cilindrica	<i>Dowel pin</i>	Zylinderstift	<i>Goupille cylindrique</i>	
<b>501</b>	5427	Tappo olio	<i>Oil plug</i>	Ölstopfen	<i>Bouchon d'huile</i>

# A10 ... A41

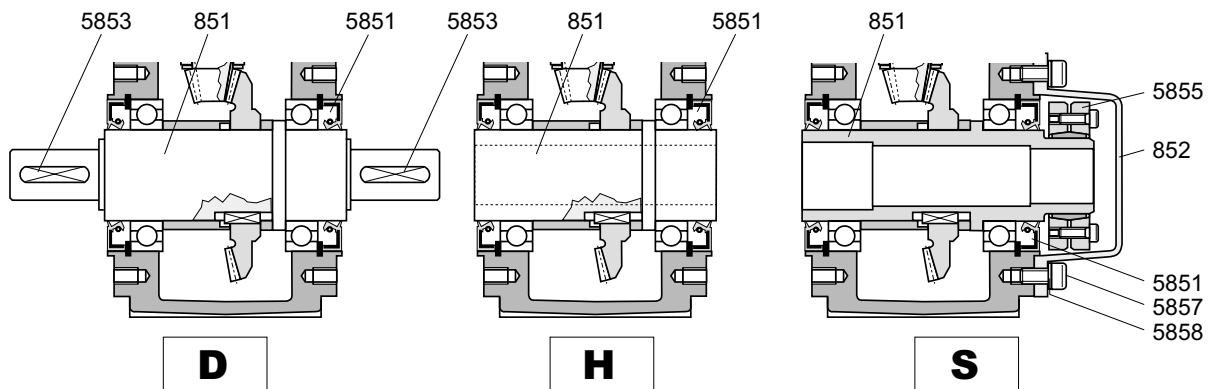
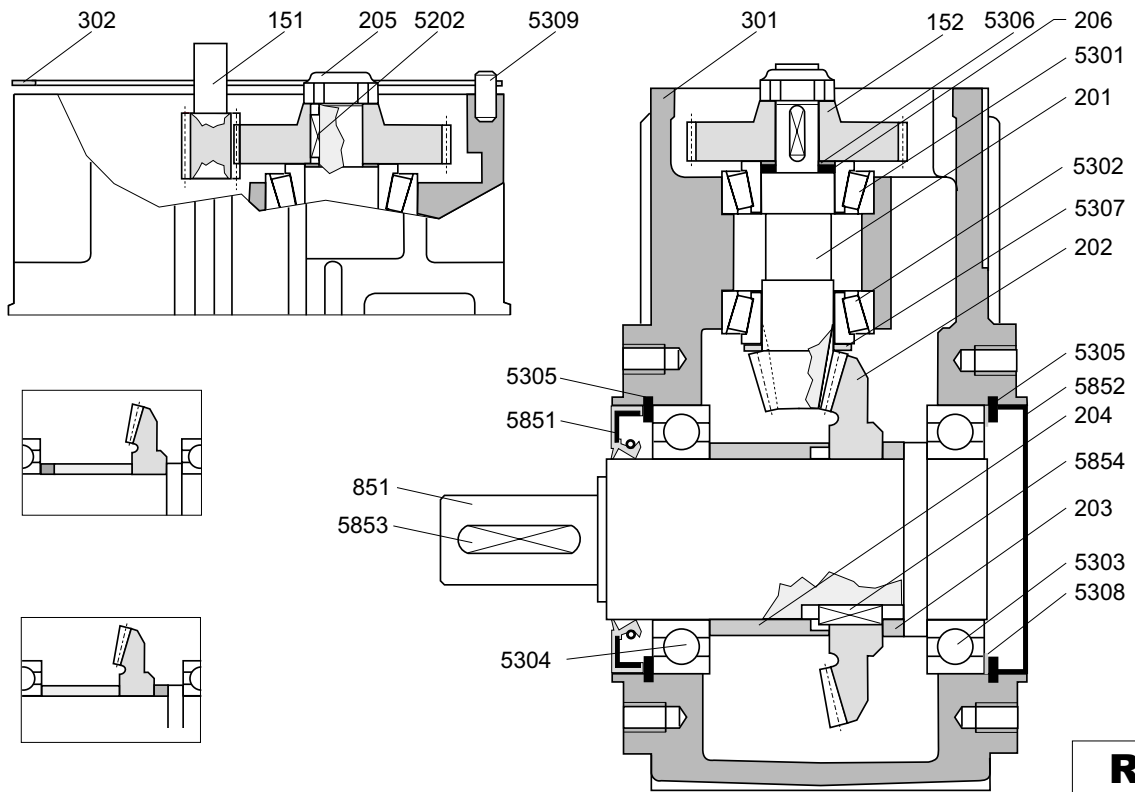

Accessori

Accessories

Zubehörteile

Accessoires

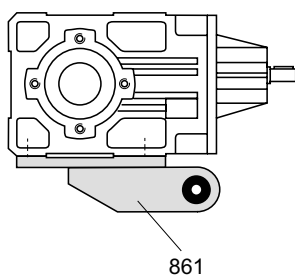

**R - D - H - S**

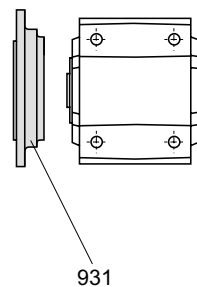

**RF - DF - HF**

A_	ref.	<b>R - D - H - S</b>			
<b>10 - 20 30 - 41</b>	151	Pignone 1ª riduzione	<i>Pinion shaft</i>	Ritzel 1. Stufe	<i>Pignon 1<sup>ère</sup> réd.</i>
	152	Corona 1ª riduzione	<i>Gear</i>	Zahnrad 1. Stufe	<i>Couronne 1<sup>ère</sup> réd.</i>
	201	Pignone conico	<i>Bevel pinion</i>	Kegelrad	<i>Pignon conique</i>
	202	Corona conica	<i>Bevel gear</i>	Kegelkranz	<i>Couronne conique</i>
	203	Distanziale	<i>Spacer ring</i>	Distanzring	<i>Entretoise</i>
	204	Distanziale	<i>Spacer ring</i>	Distanzring	<i>Entretoise</i>
	205	Ghiera	<i>Ring nut</i>	Wellenmutter	<i>Frette</i>
	301	Cassa	<i>Gear housing</i>	Gehäuse	<i>Carter</i>
	302	Guarnizione	<i>Gasket</i>	Dichtung	<i>Joint</i>
	851	Albero lento	<i>Output shaft</i>	Abtriebswelle	<i>Arbre de sortie</i>
	5202	Linguetta	<i>Key</i>	Paßfeder	<i>Clavette</i>
	5301	Cuscinetto	<i>Bearing</i>	Kugellager	<i>Roulement</i>
	5302	Cuscinetto	<i>Bearing</i>	Kugellager	<i>Roulement</i>
	5303	Cuscinetto	<i>Bearing</i>	Kugellager	<i>Roulement</i>
	5304	Cuscinetto	<i>Bearing</i>	Kugellagerr	<i>Roulement</i>
5305	Anello seeger	<i>Circlip</i>	Seegerring	<i>Seeger</i>	
5307	Ralla pignone conico	<i>Bevel pinion washer</i>	Scheibe der Kegelritzels	<i>Butée pignon conique</i>	
5308	Ralla albero lento	<i>Output shaft washer</i>	Scheibe der Abtriebswelle	<i>Butée arbre lent</i>	
5309	Spina cilindrica	<i>Dowel pin</i>	Zylinderstift	<i>Goupille cylindrique</i>	
5851	Anello di tenuta	<i>Oil seal</i>	Simmerring	<i>Bague d'étanchéité</i>	
<b>10 - 20 - 30</b>	5306	Ralla corona 1ª riduzione	<i>Washer</i>	Scheibe der 1. stufe Zahnrad	<i>Butée couronne 1<sup>ère</sup> réd.</i>
<b>30 - 41</b>	5854	Linguetta corona conica	<i>Key</i>	Paßfeder des Kegelzahnrades	<i>Clavette couronne conique</i>
<b>41</b>	206	Distanziale	<i>Spacer ring</i>	Distanzring	<i>Entretoise</i>
<b>R</b>					
<b>10 - 20 - 30 - 41</b>	5852	Cappellotto in gomma	<i>Rubber cap</i>	Gummideckel	<i>Capuchon en caoutchouc</i>
<b>R - D</b>					
<b>10 - 20 - 30 - 41</b>	5853	Linguetta albero lento	<i>Output shaft key</i>	Paßfeder der Abtriebswelle	<i>Clavette arbre lent</i>
<b>S</b>					
<b>10 - 20 - 30 - 41</b>	852	Protezione	<i>Safety cover</i>	Schutzvorrichtung	<i>Protection</i>
	5855	Calettatore	<i>Shrink disc</i>	Schrumpfscheibe	<i>Frette de serrage</i>
	5857	Vite di fissaggio	<i>Fixing screw</i>	Befestigungsschraube	<i>Vis de fixation</i>
	5858	Rosetta zigrinata	<i>Knurled washer</i>	Rändelscheibe	<i>Rondelle moletée</i>
<b>RF - DF - HF</b>					
<b>10 - 20 - 30 - 41</b>	931	Flangia	<i>Flange</i>	Flansch	<i>Bride</i>
<b>R - D - H - S</b>					
<b>10 - 20 - 30 - 41</b>	861	Kit braccio di reazione	<i>Torque arm kit</i>	Ausrüstung für Drehmomentstütze	<i>Kit bras de réaction</i>

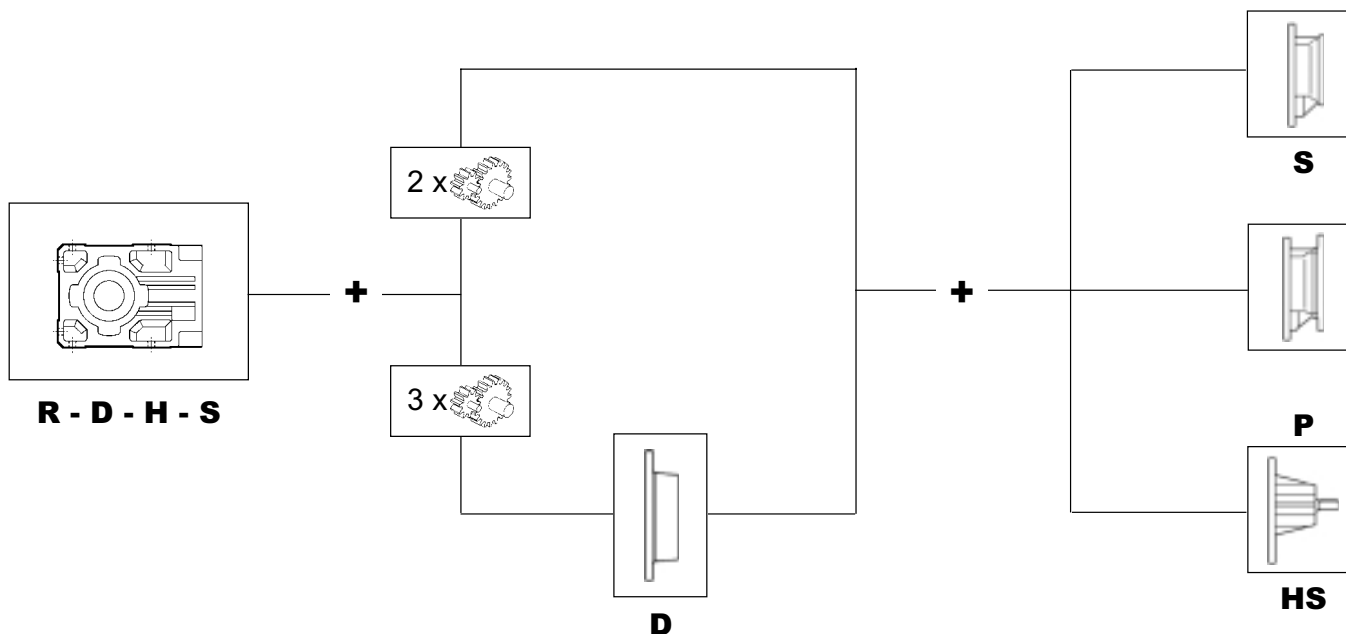

**A502**

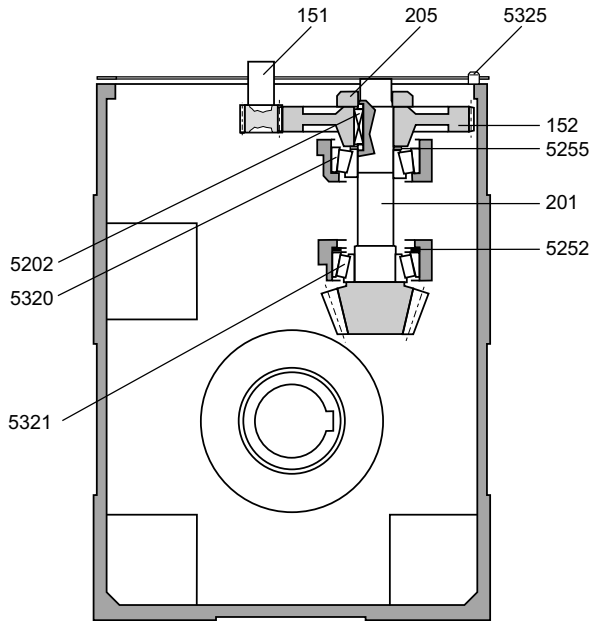

**A503 - A504**

**AL - AR**

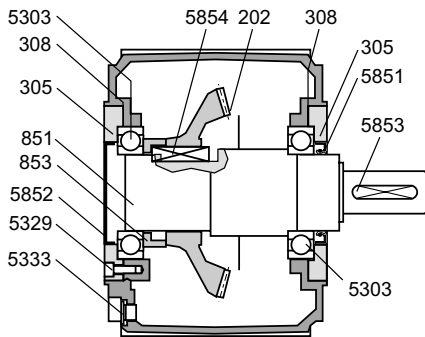
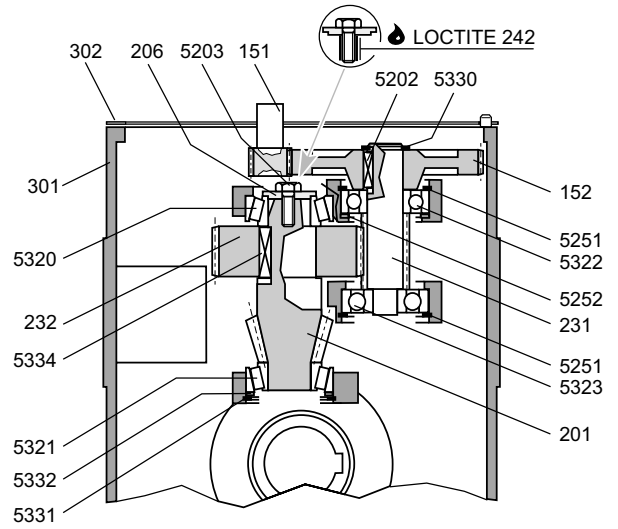
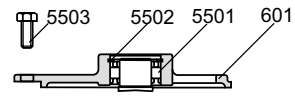

**R**

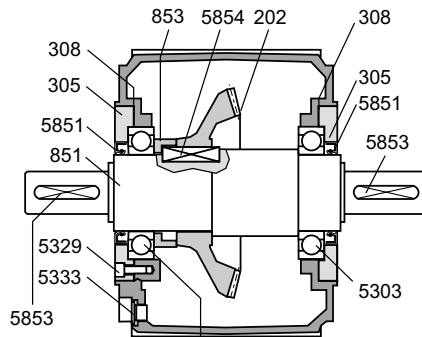

**D**

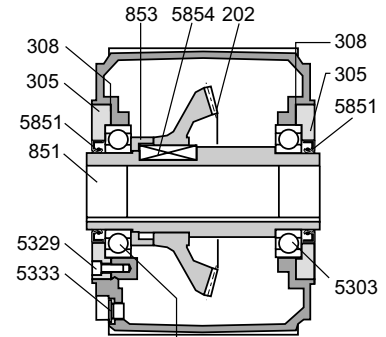

**H**

Accessori / Accessories / Zubehörteile / Accessoires

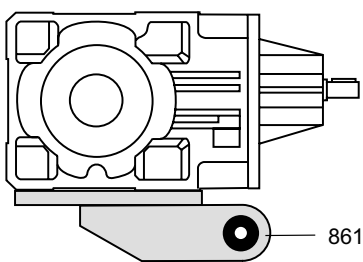

**R - D - H - S**

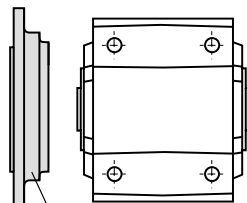

**RF - DF - HF**

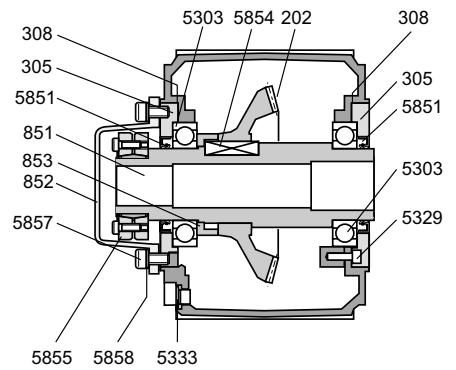

**S**

A_	ref.	<b>R - D - H - S</b>			
<b>502 503 504</b>	151	Pignone 1 <sup>a</sup> riduzione	1 <sup>st</sup> red. pinion	Ritzel 1. Stufe	Pignon 1 <sup>ère</sup> réd.
	152	Corona veloce	1 <sup>st</sup> red. gear	Zahnrad 1. Stufe	Couronne 1 <sup>ère</sup> réd.
	201	Pignone conico	Bevel pinion	Kegelrad	Pignon conique
	202	Corona conica	Bevel gear	Kegelkranz	Couronne conique
	301	Cassa	Gear housing	Gehäuse	Carter
	302	Guarnizione	Gasket	Dichtung	Joint
	305	Cappello	Cap	Deckel	Capuchon
	308	Guarnizione	Gasket	Dichtung	Joint
	851	Albero lento	Output shaft	Abtriebswelle	Arbre de sortie
	853	Distanziale	Spacer ring	Distanzring	Entretoise
	5202	Linguetta	Key	Paßfeder	Clavette
	5303	Cuscinetto	Bearing	Kugellager	Roulement
	5320	Cuscinetto	Bearing	Kugellager	Roulement
5321	Cuscinetto	Bearing	Kugellager	Roulement	
5325	Spina cilindrica	Dowel pin	Zylinderstift	Goupille cylindrique	
5329	Vite di fissaggio	Fixing screw	Befestigungsschraube	Vis de fixation	
5333	Tappo olio	Oil plug	Ölverschluß	Bouchon d'huile	
5851	Anello di tenuta	Oil seal	Simmerring	Bague d'étanchéité	
5854	Linguetta corona conica	Key	Paßfeder des Kegelzahnades	Clavette couronne conique	
<b>502</b>	205	Ghiera	Ring nut	Wellenmutter	Frette
	5252	Ralla	Washer	Scheibe	Butée
	5255	Ralla	Washer	Scheibe	Butée
<b>503 - 504</b>	206	Ralla	Washer	Wellenmutter	Frette
	231	Pignone 2 <sup>a</sup> riduzione	2 <sup>nd</sup> red. pinion	Ritzel 2. Stufe	Pignon 2 <sup>ème</sup> réd.
	232	Corona 2 <sup>a</sup> riduzione	2 <sup>nd</sup> red. gear	Zahnrad 2. Stufe	Couronne 2 <sup>ème</sup> réd.
	5203	Vite di fissaggio	Fixing screw	Befestigungsschraube	Vis de fixation
	5251	Anello seeger	Circlip	Seegerring	Seeger
	5252	Ralla	Washer	Scheibe	Butée
	5322	Cuscinetto	Bearing	Kugellager	Roulement
	5323	Cuscinetto	Bearing	Kugellager	Roulement
	5330	Anello seeger	Circlip	Seegerring	Seeger
	5331	Anello seeger	Circlip	Seegerring	Seeger
	5332	Ralla	Washer	Scheibe	Butée
5334	Linguetta	Key	Paßfeder	Clavette	
<b>R</b>					
<b>502 - 503 - 504</b>	5852	Cappello in gomma	Rubber cap	Gummideckel	Capuchon en caoutchouc
<b>R - D</b>					
<b>502 - 503 - 504</b>	5853	Linguetta albero lento	Output shaft key	Paßfeder der Abtriebswelle	Clavette arbre lent
<b>S</b>					
<b>502 - 503 - 504</b>	852	Protezione	Safety cover	Schutzvorrichtung	Protection
	5855	Calettatore	Shrink disc	Schrumpfscheibe	Frette de serrage
	5857	Vite di fissaggio	Fixing screw	Befestigungsschraube	Vis de fixation
	5858	Rosetta zigrinata	Knurled washer	Rändelscheibe	Rondelle moletée
<b>URF - UDF - UHF</b>					
<b>502 - 503 - 504</b>	931	Flangia	Flange	Flansch	Bride
<b>R - D - H - S</b>					
<b>502 - 503 - 504</b>	861	Kit braccio di reazione	Torque arm kit	Ausrüstung für Drehmomentstütze	Kit bras de réaction
<b>AL- AR</b>					
<b>503 - 504</b>	601	Supporto antiretro	Anti-run-back support	Halter für Rückzugssperre	Support anti-retrait
	5501	Ruota libera	Free wheel	Freilauf	Roue libre
	5502	Anello seeger	Circlip	Seegerring	Seegerr
	5503	Vite di fissaggio	Fixing screw	Befestigungsschraube	Vis de fixation

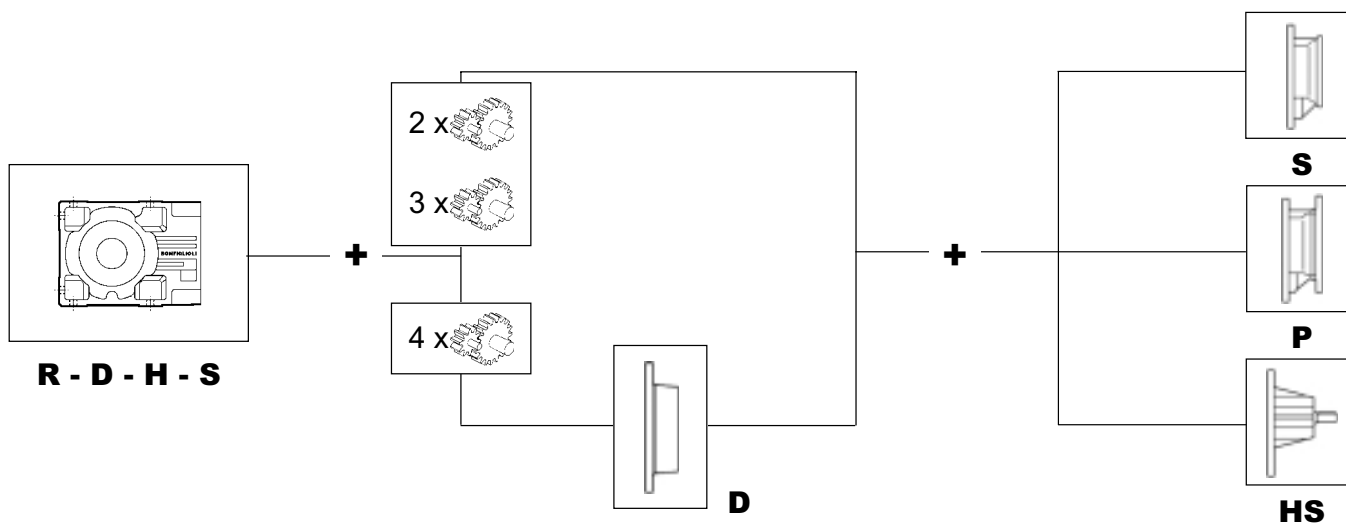

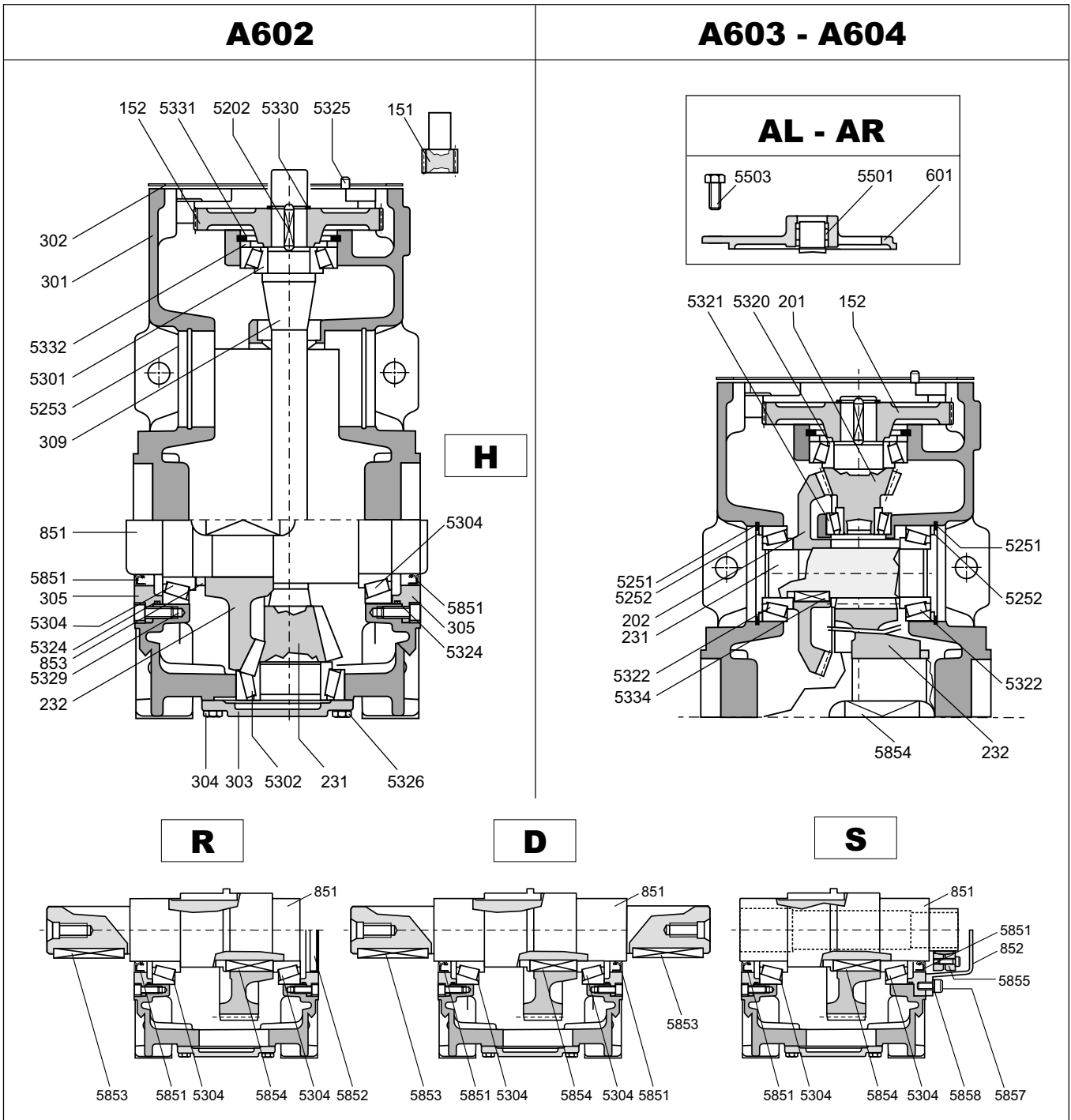

Accessori / Accessories / Zubehörteile / Accessoires

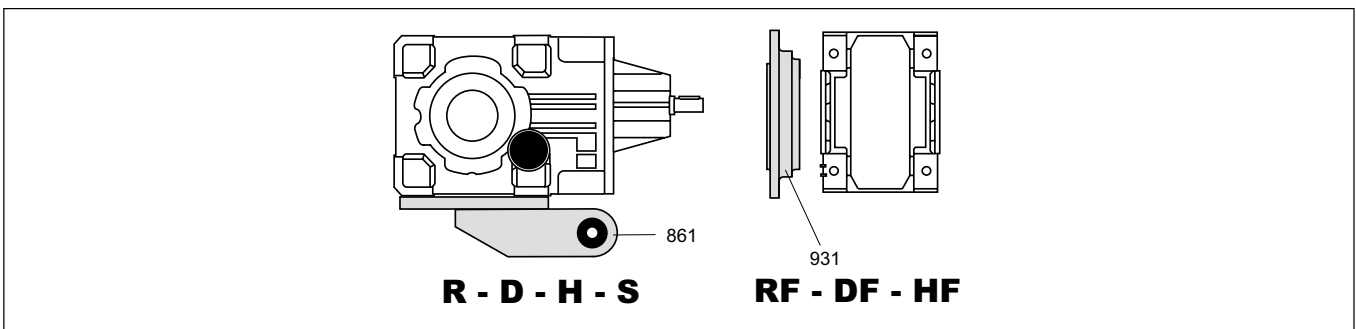

A	ref.	<b>R - D - H - S</b>			
<b>602-603-604</b>	151	Pignone 1 <sup>a</sup> riduzione	1 <sup>st</sup> red. pinion	Ritzel 1. Stufe	Pignon 1 <sup>ère</sup> réd.
	152	Corona 1 <sup>a</sup> riduzione	1 <sup>st</sup> red. gear	Zahnrad 1. Stufe	Couronne 1 <sup>ère</sup> réd.
	301	Cassa	Gear housing	Gehäuse	Carter
	302	Guarnizione	Gasket	Dichtung	Joint
	303	Coperchio di chiusura	Cover	Schlußdeckel	Couvercle de fermeture
	304	Guarnizione	Gasket	Dichtung	Joint
	305	Cappellotto	Cap	Deckel	Capuchon
	851	Albero lento	Output shaft	Abtriebswelle	Arbre de sortie
	5202	Linguetta	Key	Paßfeder	Clavette
	5253	Cappellotto in gomma	Rubber cap	Gummideckel	Capuchon en caoutchouc
	5304	Cuscinetto	Bearing	Kugellager	Roulement
	5324	Anello O-Ring	O-Ring seal	O-Ring	Bague O-ring
	5325	Spina cilindrica	Dowel pin	Zylinderstift	Goupille cylindrique
	5326	Vite di fissaggio	Fixing screw	Befestigungsschraube	Vis de fixation
	5329	Vite di fissaggio	Fixing screw	Befestigungsschraube	Vis de fixation
	5330	Anello seeger	Circlip	Seegerring	Seeger
	5331	Anello seeger	Circlip	Seegerring	Seeger
5332	Ralla	Washer	Scheibe	Capuchon	
5851	Anello di tenuta	Oil seal	Simmerring	Bague d'étanchéité	
5854	Linguetta	Key	Paßfeder	Clavette	
<b>602</b>	231	Pignone conico	Bevel pinion	Kegelrad	Pignon conique
	232	Corona conica	Bevel gear	Kegelkranz	Couronne conique
	309	Alb. inserto	Module shaft	Modulwelle	Arbre module
	853	Distanziale	Spacer ring	Distanzring	Entretoise
	5301	Cuscinetto	Bearing	Kugellager	Roulement
	5302	Cuscinetto	Bearing	Kugellager	Roulement
<b>603 - 604</b>	201	Pignone conico	Bevel pinion	Kegelrad	Pignon conique
	202	Corona conica	Bevel gear	Kegelkranz	Couronne conique
	231	Pignone lento	Output pinion	Abtriebsritze	Pignon à la sortie
	232	Corona lenta	Output gear	Abtriebszahnrad	Couronne à la sortie
	5251	Anello seeger	Circlip	Seegerring	Seeger
	5252	Ralla	Washer	Scheibe	Butée
	5320	Cuscinetto	Bearing	Kugellager	Roulement
	5321	Cuscinetto	Bearing	Kugellager	Roulement
	5322	Cuscinetto	Bearing	Kugellager	Roulement
	5334	Linguetta	Key	Paßfeder	Clavette
<b>R</b>					
<b>602 - 603 - 604</b>	5852	Cappellotto in gomma	Rubber cap	Gummideckel	Capuchon en caoutchouc
<b>R - D</b>					
<b>602 - 603 - 604</b>	5853	Linguetta albero lento	Output shaft key	Paßfeder der Abtriebswelle	Clavette arbre lent
<b>S</b>					
<b>602 - 603 - 604</b>	852	Protezione	Safety cover	Schutzvorrichtung	Protection
	5855	Calettatore	Shrink disc	Schrumpfscheibe	Frette de serrage
	5857	Vite di fissaggio	Fixing screw	Befestigungsschraube	Vis de fixation
	5858	Rosetta zigrinata	Knurled washer	Rändelscheibe	Rondelle moletée
<b>RF - DF - HF</b>					
<b>602 - 603 - 604</b>	931	Flangia	Flange	Flansch	Bride
<b>R - D - H - S</b>					
<b>602 - 603 - 604</b>	861	Kit braccio di reazione	Torque arm kit	Ausrüstung für Drehmomentstütze	Kit bras de réaction
<b>AL - AR</b>					
<b>603 - 604</b>	601	Supporto antiretro	Anti-run-back support	Halter für Rückzugssperre	Douille antiretrait
	5501	Ruota libera	Free wheel	Freilauf	Roue libre
	5503	Vite di fissaggio	Fixing screw	Befestigungsschraube	Vis de fixation

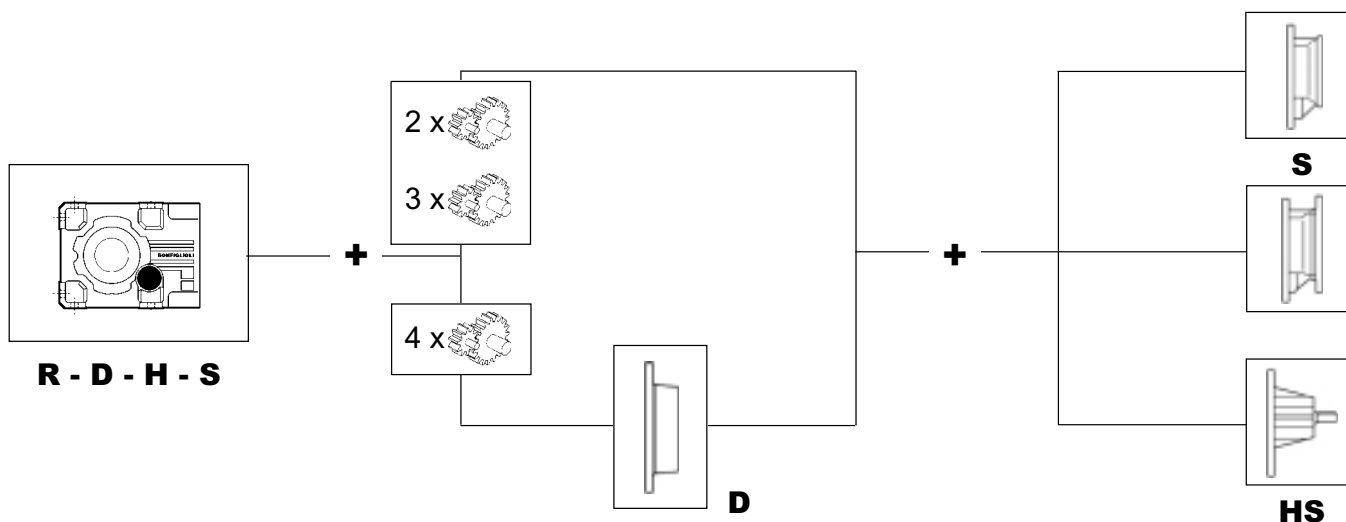

## A70 ... A90

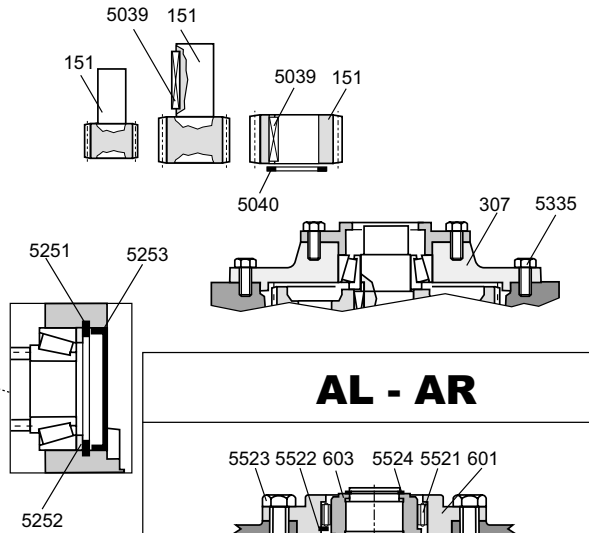
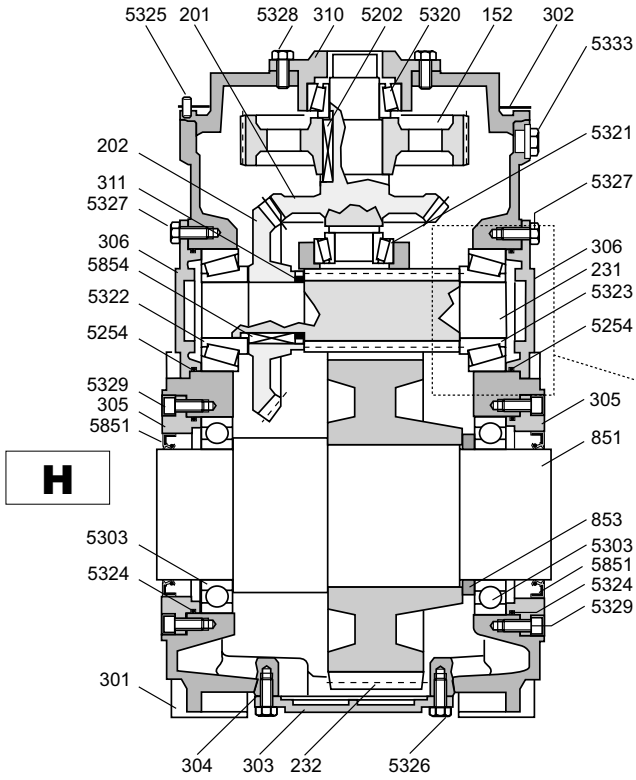

### AL - AR

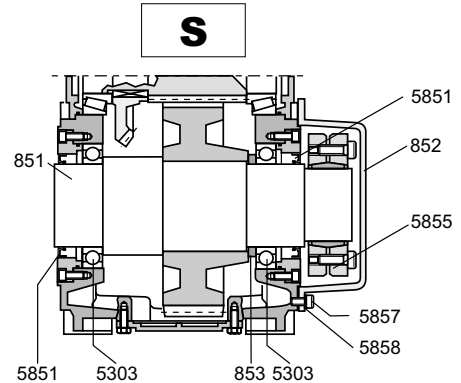
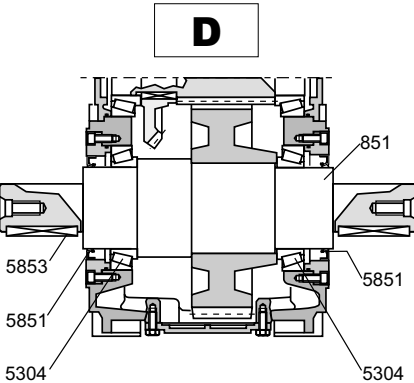
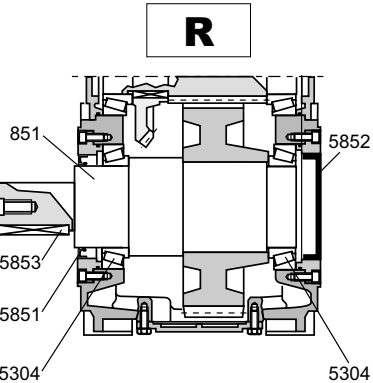
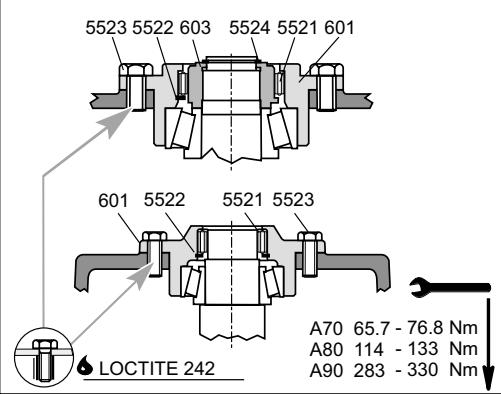

Accessori / Accessories / Zubehörteile / Accessoires

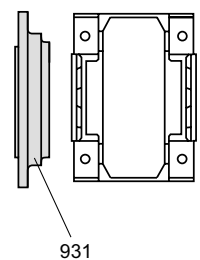
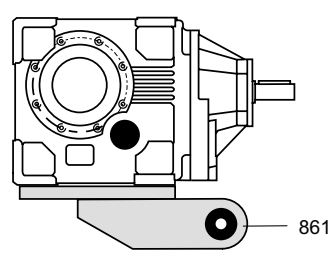

**R - D - H - S**

**RF - DF - HF**

<b>A</b>	ref.	<b>R - D - H - S</b>			
<b>70-80-90</b>	151	Pianone 1ª riduzione	1 <sup>st</sup> red. pinion	Ritzel 1. Stufe	Pignon 1 <sup>ère</sup> réd.
	152	Corona 1ª riduzione	1 <sup>st</sup> red. gear	Zahnrad 1. Stufe	Couronne 1 <sup>ère</sup> réd.
	201	Pianone conico	Bevel pinion	Kegelrad	Pignon conique
	202	Corona conica	Bevel gear	Kegelkranz	Couronne conique
	231	Pianone lento	Output pinion	Abtriebsritzel	Pignon à la sortie
	232	Corona lenta	Output gear	Abtriebszahnrad	Couronne à la sortie
	301	Cassa	Gear housing	Gehäuse	Carter
	302	Guarnizione	Gasket	Dichtung	Joint
	303	Coperchio di chiusura	Cover	Schlußdeckel	Couvercle de fermeture
	304	Guarnizione	Gasket	Dichtung	Joint
	305	Cappello alb. lento	Cover	Deckel	Capuchon
	310	Supporto cuscinetto	Bearing support	Lageraufnahme	Support roulement
	311	Distanziale	Spacer ring	Distanzring	Entretoise
	851	Albero lento	Output shaft	Abtriebswelle	Arbre de sortie
	5039	Linguetta	Key	Paßfeder	Clavette
	5040	Anello seeger	Circlip	Seegerring	Seeger
	5202	Linguetta	Key	Paßfeder	Clavette
	5320	Cuscinetto	Bearing	Kugellager	Roulement
	5321	Cuscinetto	Bearing	Kugellager	Roulement
	5322	Cuscinetto	Bearing	Kugellager	Roulement
5323	Cuscinetto	Bearing	Kugellager	Roulement	
5324	Anello O-Ring	O-Ring seal	O-Ring	Bague O-ring	
5325	Spina cilindrica	Dowel pin	Zylinderstift	Goupille cylindrique	
5326	Vite di fissaggio	Fixing screw	Befestigungsschraube	Vis de fixation	
5328	Vite di fissaggio	Fixing screw	Befestigungsschraube	Vis de fixation	
5329	Vite di fissaggio	Fixing screw	Befestigungsschraube	Vis de fixation	
5333	Tappo olio	Oil plug	Ölverschluß	Bouchon d'huile	
5851	Anello di tenuta	Oil seal	Simmerring	Bague d'étanchéité	
5854	Linguetta	Key	Paßfeder	Clavette	
<b>70</b>	5251	Anello seeger	Circlip	Seegerring	Seeger
	5252	Ralla	Washer	Scheibe	Butée
	5253	Cappello in gomma	Rubber cap	Gummideckel	Capuchon en caoutchouc
<b>80 - 90</b>	306	Cappello chiuso	Cover	Geschlossener Deckel	Capuchon fermé
	307	Supporto interno	Internal support	Innerer Halter	Support interne
	5254	Anello O-Ring	O-Ring seal	O-Ring	Bague O-ring
	5327	Vite di fissaggio	Fixing screw	Befestigungsschraube	Vis de fixation
5335	Vite supporto cuscinetto	Bearing support screw	Schraube für Lagerauf	Vis de support roulement	
<b>H</b>					
<b>70 - 80 - 90</b>	5303	Cuscinetto	Bearing	Kugellager	Roulement
	853	Distanziale	Spacer ring	Distanzring	Entretoise
<b>R</b>					
<b>70 - 80 - 90</b>	5304	Cuscinetto	Bearing	Kugellager	Roulement
	5853	Linguetta albero lento	Output shaft key	Paßfeder der Abtriebswelle	Clavette arbre lent
	5852	Cappello in gomma	Rubber cap	Gummideckel	Capuchon en caoutchouc
<b>D</b>					
<b>70 - 80 - 90</b>	5304	Cuscinetto	Bearing	Kugellager	Roulement
	5853	Linguetta albero lento	Key output shaft	Paßfeder der Abtriebswelle	Clavette arbre lent
<b>S</b>					
<b>70 - 80 - 90</b>	852	Protezione	Guard	Schutzvorrichtung	Protection
	853	Distanziale	Spacer ring	Distanzring	Entretoise
	5303	Cuscinetto	Bearing	Kugellager	Roulement
	5855	Calettatore	Shrink disc	Schrumpfscheibe	Frette de serrage
	5857	Vite di fissaggio	Fixing screw	Befestigungsschraube	Vis de fixation
	5858	Rosetta zigrinata	Knurled washer	Rändelscheibe	Rondelle moletée
<b>RF - DF - HF - SF</b>					
<b>70 - 80 - 90</b>	931	Flangia	Flange	Flansch	Bride
<b>R - D - H - S</b>					
<b>70 - 80 - 90</b>	861	Kit braccio di reazione	Torque arm kit	Ausrüstung für Drehmomentstütze	Kit bras de réaction
<b>AL - AR</b>					
<b>80</b>	601	Supporto antiretro	Anti-run-back support	Halter für Rückzugsperr	Support anti-retrait
	5521	Ruota libera	Free wheel	Freilauf	Roue libre
	5523	Vite di fissaggio	Fixing screw	Befestigungsschraube	Vis de fixation
<b>70 - 90</b>	601	Supporto antiretro	Anti-run-back support	Halter für Rückzugsperr	Support anti-retrait
	603	Boccola per antiretro	Anti-run-back spacer ring	Buchse für Rücklaufsicherung	Douille antiretrait
	5521	Ruota libera	Free wheel	Freilauf	Roue libre
	5522	Anello Seeger	Circlip	Seegerring	Seeger
	5523	Vite di fissaggio	Fixing screw	Befestigungsschraube	Vis de fixation
5524	Anello Seeger	Circlip	Seegerring	Seeger	

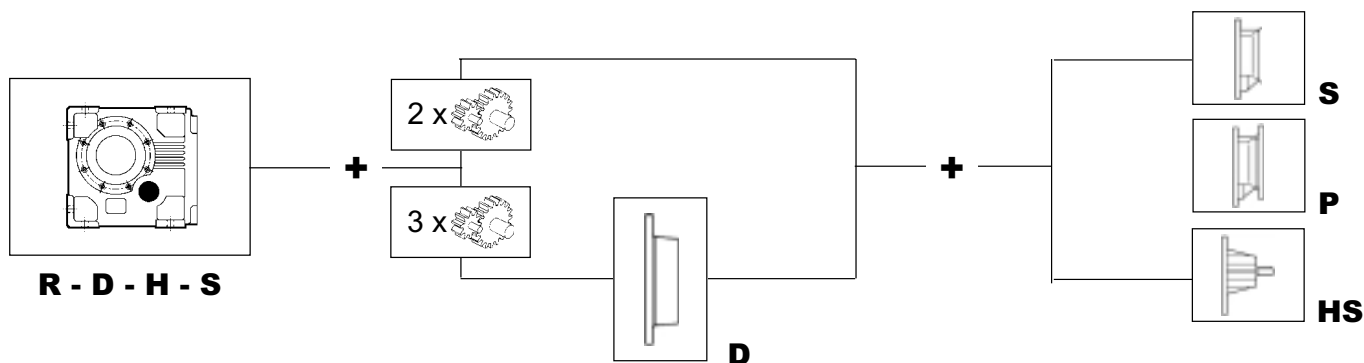

# F10 - F20

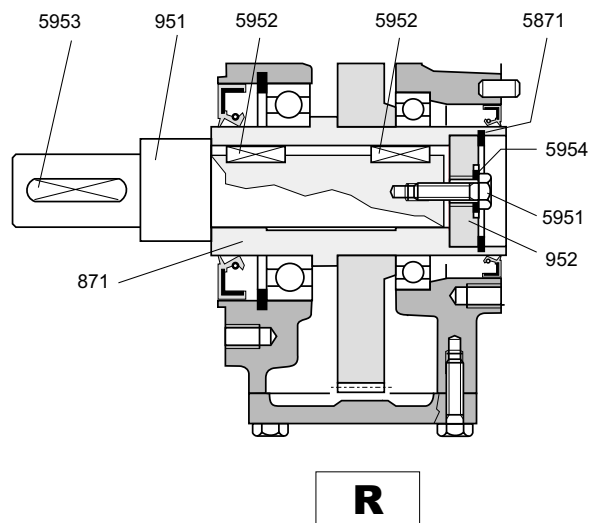
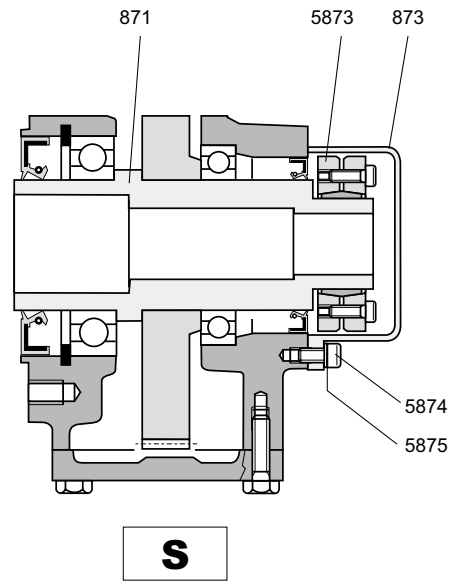
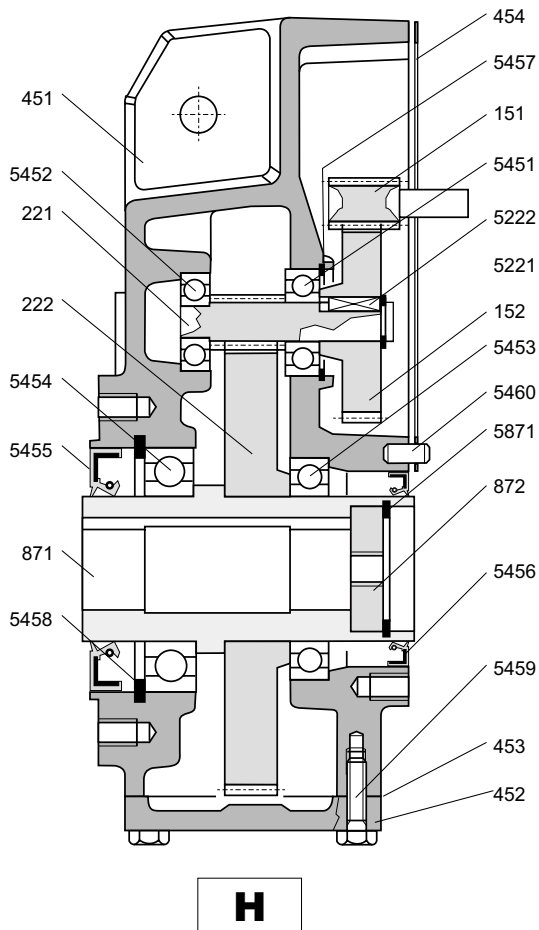

Accessori

Accessories

Zubehörteile

Accessoires

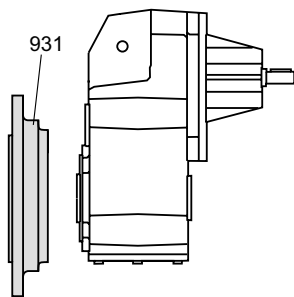

**HF - SF - RF**

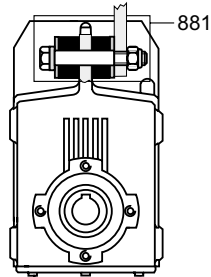

**H - S - R**

F_	ref.	<b>H - S - R</b>			
<b>10 - 20</b>	151	Pignone 1ª riduzione	1 <sup>st</sup> red. pinion	Ritzel 1. Stufe	Pignon 1 <sup>ère</sup> réd.
	152	Corona 1ª riduzione	1 <sup>st</sup> red. gear	Zahnrad 1. Stufe	Couronne 1 <sup>ère</sup> réd.
	221	Pignone lento	Output pinion	Abtriebsritzel	Pignon à la sortie
	222	Corona lenta	Output gear	Abtriebszahnrad	Couronne à la sortie
	451	Cassa	Gear housing	Gehäuse	Carter
	452	Coperchio di chiusura	Cover	Schlußdeckel	Couvercle de fermeture
	453	Guarnizione coperchio	Gasket	Dichtung	Joint couvercle
	454	Guarnizione cassa	Gasket	Dichtung	Joint carter
	871	Albero lento	Output shaft	Abtriebswelle	Arbre de sortie
	5221	Anello seeger	Seeger	Seegerring	Seeger
	5222	Linguetta	Key	Paßfeder	Clavette
	5451	Cuscinetto	Bearing	Kugellager	Roulement
	5452	Cuscinetto	Bearing	Kugellager	Roulement
	5453	Cuscinetto	Bearing	Kugellager	Roulement
	5454	Cuscinetto	Bearing	Kugellager	Roulement
	5455	Anello di tenuta	Oil seal	Simmerring	Bague d'étanchéité
	5456	Anello di tenuta	Oil seal	Simmerring	Bague d'étanchéité
	5457	Anello seeger	Circlip	Seegerring	Seeger
5458	Anello seeger	Circlip	Seegerring	Seeger	
5459	Vite di fissaggio coperchio	Bolt	Deckel -Befestigungsschraube	Vis de fixation couvercle	
5460	Spina cilindrica	Dowel pin	Zylinderstift	Goupille cylindrique	
<b>H</b>					
<b>10 - 20</b>	872	Ralla albero lento	Assembly ring	Scheibe der abtriebswelle	Boutée arbre lent
	5871	Anello seeger	Circlip	Seegerring	Seeger
<b>R</b>					
<b>10 - 20</b>	951	Albero lento	Output shaft	Abtriebswelle	Arbre lent
	952	Ralla albero lento	Assembly ring	Scheibe der Abtriebswelle	Boutée arbre lent
	5871	Anello seeger	Circlip	Seegerring	Seeger
	5951	Vite di fissaggio	Fixing screw	Befestigungsschraube	Vis de fixation
	5952	Linguetta	Key	Paßfeder	Clavette
	5953	Linguetta	Key	Paßfeder	Clavette
	5954	Rosetta	Washer	Scheibe	Rondelle
<b>S</b>					
<b>10 - 20</b>	873	Protezione	Safety cover	Schutzvorrichtung	Protection
	5873	Calettatore	Shrink disc	Schrumpfscheibe	Frette de serrage
	5874	Vite di fissaggio	Fixing screw	Befestigungsschraube	Vis de fixation
	5875	Rosetta zigrinata	Knurled washer	Rändelscheibe	Rondelle muletée
<b>HF - SF - RF</b>					
<b>10 - 20</b>	931	Flangia	Flange	Flansch	Bride
<b>H - S - R</b>					
<b>10 - 20</b>	881	Kit di fissaggio con boccia antivibrante	Anti-vibration kit	Dämpfungs kit	Kit de fixation pour bras de réaction avec butée en caoutchouc

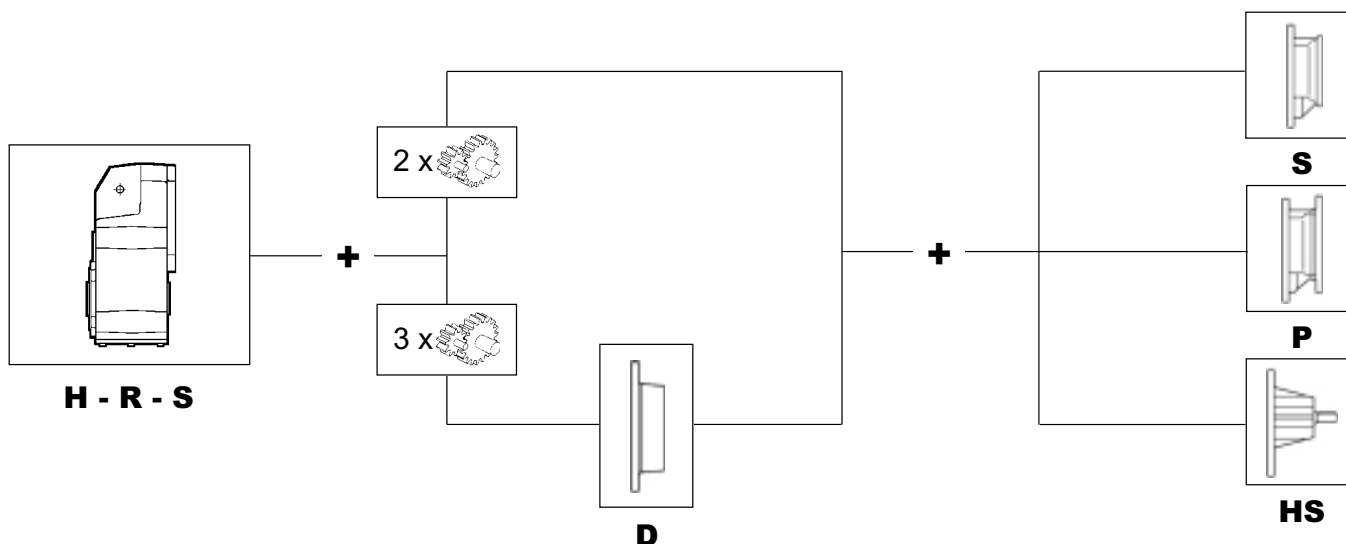

**F302 - F402 - F502**

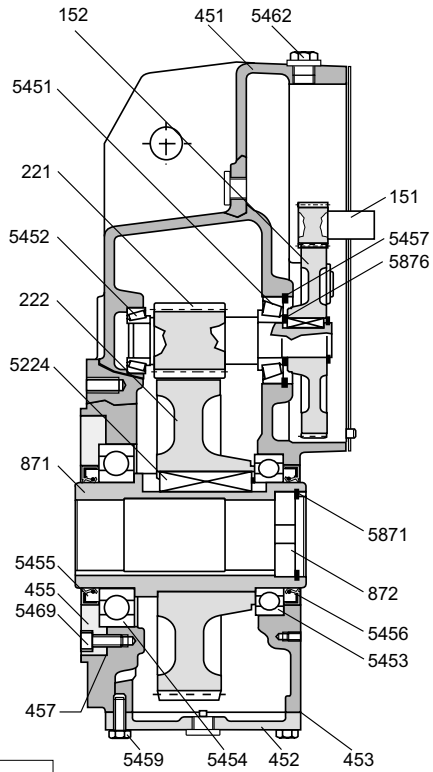

**H**

**F303 - F403 - F503  
F304 - F404 - F504**

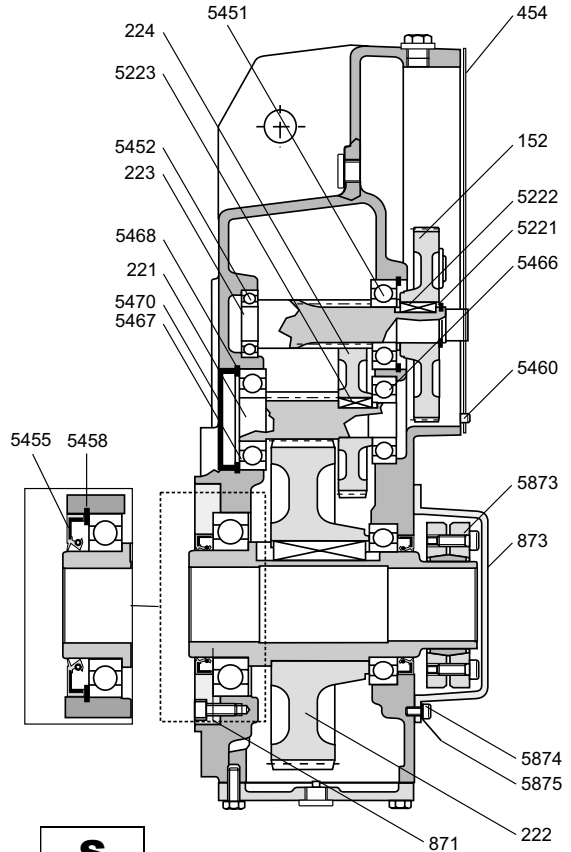

**S**

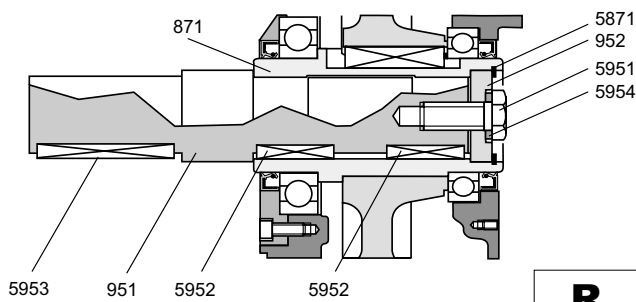

**R**

**AL - AR**

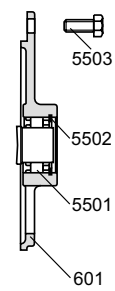

Accessori

Accessories

Zubehörteile

Accessoires

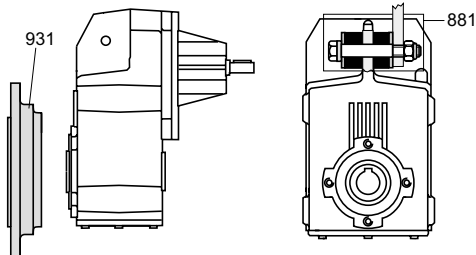

**HF - SF - RF**

**H - S - R**

F	ref.	<b>H - S - R</b>			
30 - 40 - 50	151	Pignone 1ª riduzione	1 <sup>st</sup> red. pinion	Ritzel 1. Stufe	Pignon 1 <sup>ère</sup> réd.
	152	Corona 1ª riduzione	1 <sup>st</sup> red. gear	Zahnrad 1. Stufe	Couronne 1 <sup>ère</sup> réd.
	221	Pionone lento	Output pinion	Abtriebsritzel	Pignon à la sortie
	222	Corona lenta	Output gear	Abtriebszahnrad	Couronne à la sortie
303 - 403 - 503 304 - 404 - 504	223	Pionone 2ª rid.	2 <sup>nd</sup> red. pinion	Ritzel 1. Stufe	Pignon 2 <sup>ème</sup> réd.
	224	Corona 2ª rid.	2 <sup>nd</sup> red. gearwheel	Zahnrad 2. Stufe	Couronne 2 <sup>ème</sup> réd.
30 - 40 - 50	451	Cassa	Gear housing	Gehäuse	Carter
	452	Coperchio di chiusura	Cover	Schlußdeckel	Couvercle de fermeture
	453	Guarnizione coperchio	Gasket	Dichtung	Joint couvercle
	454	Guarnizione cassa	Gasket	Dichtung	Joint carter
	871	Albero lento	Output shaft	Abtriebswelle	Arbre de sortie
	5221	Anello seeger	Seeger	Seegerring	Seeger
	5222	Linguetta	Key	Paßfeder	Clavette
	5223	Linguetta	Key	Paßfeder	Clavette
	5224	Linguetta	Key	Paßfeder	Clavette
	5451	Cuscinetto	Bearing	Kugellager	Roulement
	5452	Cuscinetto	Bearing	Kugellager	Roulement
	5453	Cuscinetto	Bearing	Kugellager	Roulement
	5454	Cuscinetto	Bearing	Kugellager	Roulement
	5455	Anello di tenuta	Oil seal	Simmerring	Bague d'étanchéité
5456	Anello di tenuta	Oil seal	Simmerring	Bague d'étanchéité	
5457	Anello seeger	Circlip	Seegerring	Seeger	
5459	Vite di fissaggio	Fixing screw	Befestigungsschraube	Vis de fixation	
30 - 40	5458	Anello seeger	Circlip	Seegerring	Seeger
30 - 40 - 50	5460	Spina cilindrica	Dowel pin	Zylinderstift	Goupille cylindrique
303 - 403 - 503 304 - 404 - 504	5466	Cuscinetto	Bearing	Kugellager	Roulement
	5467	Cuscinetto	Bearing	Kugellager	Roulement
	5468	Anello seeger	Circlip	Seegerring	Seeger
	5470	Cappello in gomma	Rubber cap	Gummiendeckel	Capuchon en caoutchouc
30 - 40 - 50	5876	Ralla	Washer	Scheibe	Butée
40 - 50	5462	Tappo olio	Oil plug	Ölverschluß	Bouchon d'huile
50	455	Cappello	Cap	Deckel	Capuchon
	457	Guarnizione	Gasket	Dichtung	Joint
	5469	Vite di fissaggio	Fixing screw	Befestigungsschraube	Vis de fixation
<b>H</b>					
30 - 40 - 50	872	Ralla albero lento	Assembly ring	Scheibe der abtriebswelle	Boutée arbre lent
	5871	Anello seeger	Circlip	Seegerring	Seeger
<b>R</b>					
30 - 40 - 50	951	Albero lento	Output shaft	Abtriebswelle	Arbre lent
	952	Rondella albero lento	Assembly ring	Scheibe der Abtriebswelle	Boutée arbre lent
	5871	Anello seeger	Circlip	Seegerring	Seeger
	5951	Vite di fissaggio	Fixing screw	Befestigungsschraube	Vis de fixation
	5952	Linguetta	Key	Paßfeder	Clavette
	5953	Linguetta	Key	Paßfeder	Clavette
5954	Rosetta	Washer	Scheibe	Rondelle	
<b>S</b>					
30 - 40 - 50	873	Protezione calettatore	Safety cover	Schutzvorrichtung	Protection
	5873	Calettatore	Shrink disc	Schrumpfscheibe	Frette de serrage
	5874	Vite di fissaggio	Fixing screw	Befestigungsschraube	Vis de fixation
	5875	Rosetta zigrinata	Knurled washer	Rändelscheibe	Rondelle moletée
<b>HF - SF - RF</b>					
30 - 40 - 50	931	Flangia	Flange	Flansch	Bride
<b>H - S - R</b>					
30 - 40 - 50	881	Kit di fissaggio con boccola antivibrante	Anti-vibration kit	Dämpfungskit	Kit de fixation pour bras de réaction avec butée en caoutchouc
<b>AL - AR</b>					
503 - 504	601	Supporto antiretro	Anti-run-back support	Halter für Rückzugssperre	Douille antiretrait
	5501	Ruota libera	Free wheel	Freilauf	Roue libre
	5502	Anello seeger	Circlip	Seegerring	Seeger
	5503	Vite di fissaggio	Fixing screw	Befestigungsschraube	Vis de fixation

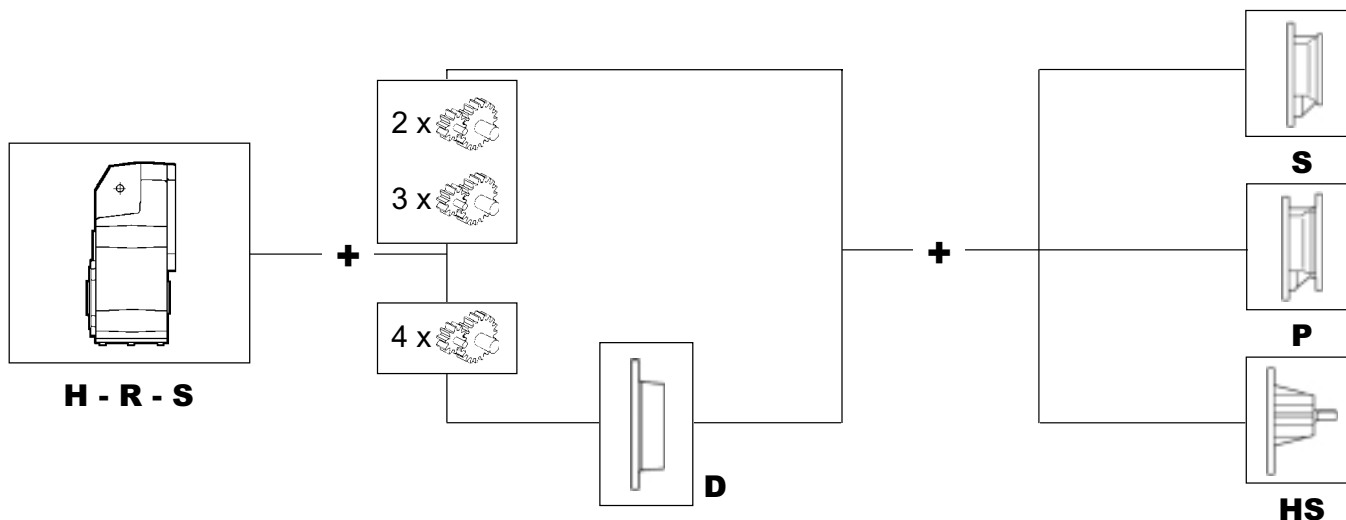

**F60 ... F90**

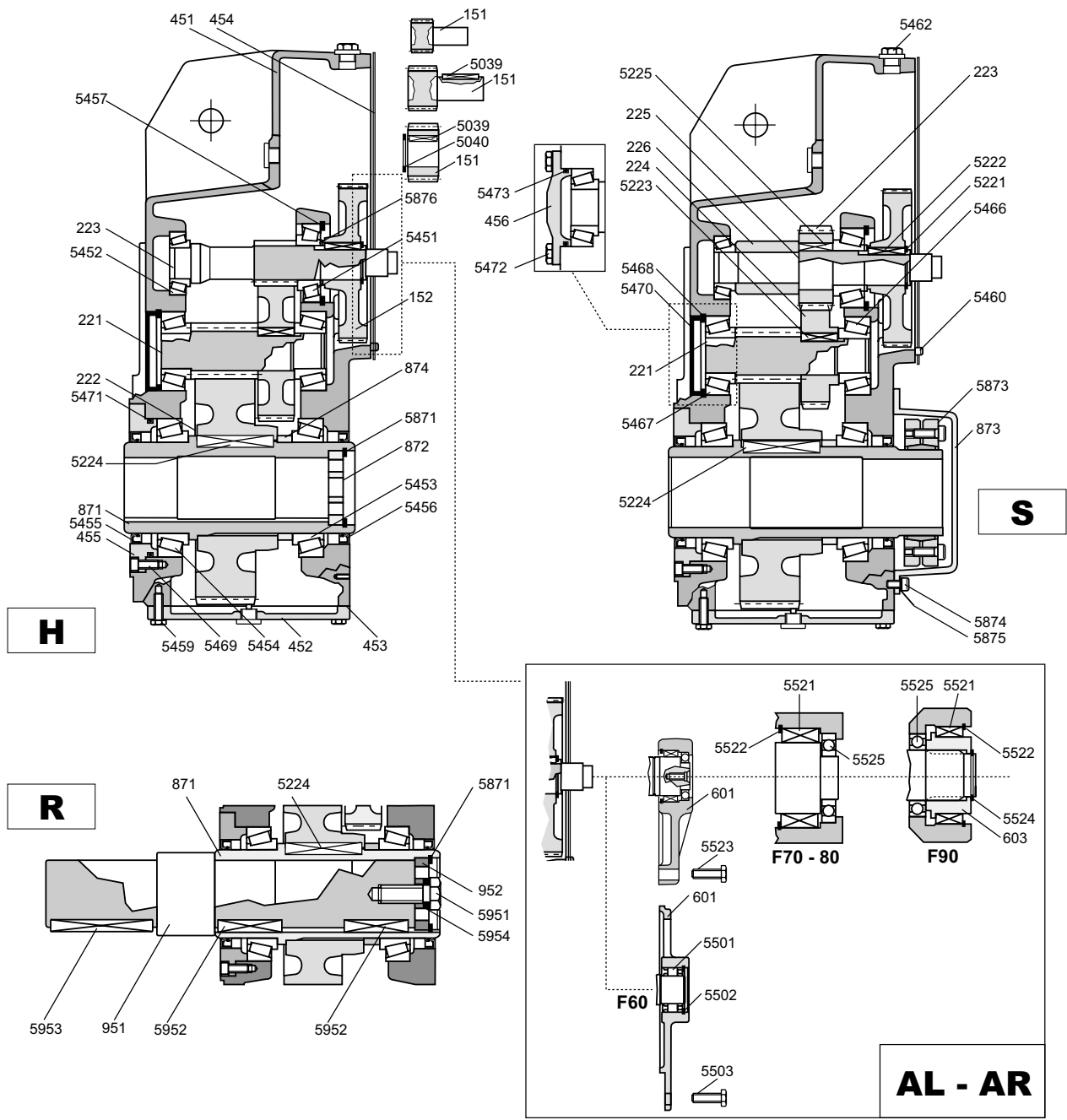

Accessori

Accessories

Zubehörteile

Accessoires

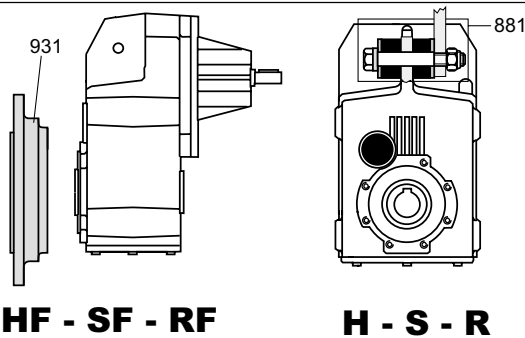

F	ref.	<b>H - S - R</b>			
<b>60 - 70 - 80 - 90</b>	151	Pignone 1ª riduzione	1 <sup>st</sup> red. pinion	Ritzel 1. Stufe	Pignon 1 <sup>ère</sup> réd.
	152	Corona 1ª riduzione	1 <sup>st</sup> red. gearwheel	Zahnrad 1. Stufe	Couronne 1 <sup>ère</sup> réd.
	221	Pianone lento	Output pinion	Abtriebsritzel	Pignon à la sortie
	222	Corona lenta	Output gear	Abtriebszahnrad	Couronne à la sortie
	223	Pianone 2a rid.	2 <sup>nd</sup> red. pinion	Ritzel 2. Stufe	Pignon 2 <sup>ème</sup> réd.
	224	Corona 2a rid.	2 <sup>nd</sup> red. gear	Zahnrad 2. Stufe	Couronne 2 <sup>ème</sup> réd.
	451	Cassa	Gear housing	Gehäuse	Carter
	452	Coperchio di chiusura	Cover	Schlußdeckel	Couvercle de fermeture
	453	Guarnizione coperchio	Gasket	Dichtung	Joint couvercle
	454	Guarnizione cassa	Gasket	Dichtung	Joint carter
	455	Cappello	Cap	Deckel	Capuchon
	871	Albero lento	Output shaft	Abtriebswelle	Arbre de sortie
	874	Distanziale	Spacer ring	Distanzring	Entretois
	5221	Anello seeger	Circlip	Seegerring	Seeger
	5222	Linguetta	Key	Paßfeder	Clavette
	5223	Linguetta	Key	Paßfeder	Clavette
	5451	Cuscinetto	Bearing	Kugellager	Roulement
	5452	Cuscinetto	Bearing	Kugellager	Roulement
	5453	Cuscinetto	Bearing	Kugellager	Roulement
	5454	Cuscinetto	Bearing	Kugellager	Roulement
5455	Anello di tenuta	Oil seal	Simmerring	Bague d'étanchéité	
5456	Anello di tenuta	Oil seal	Simmerring	Bague d'étanchéité	
5457	Anello seeger	Circlip	Seegerring	Seeger	
5459	Vite di fissaggio coperchio	Bolt	Deckel -Befestigungsschraube	Vis de fixation couvercle	
5460	Spina cilindrica	Dowel pin	Zylinderstift	Goupille cylindrique	
5462	Tappo olio	Oil plug	Ölverschluß	Bouchon d'huile	
5466	Cuscinetto	Bearing	Kugellager	Roulement	
5467	Cuscinetto	Bearing	Kugellager	Roulement	
5469	Vite di fissaggio	Fixing screw	Befestigungsschraube	Vis de fixation	
5471	Anello O-Ring	O-ring seal	O-Ring	Bague O-ring	
<b>60</b>	5224	Linguetta	Key	Paßfeder	Clavette
<b>60 - 70</b>	5468	Anello seeger	Circlip	Seegerring	Seeger
	5470	Cappello in gomma	Rubber cap	Gummideckel	Capuchon en caoutchouc
<b>60 - 70 - 90</b>	225	Albero inserto	Shaft	Modulwelle	Arbre module
	226	Distanziale	Spacer	Distanzring	Entretois
	5225	Linguetta	Key	Paßfeder	Clavette
<b>70 - 80 - 90</b>	5039	Linguetta	Key	Paßfeder	Clavette
	5040	Anello seeger	Circlip	Seegerring	Seeger
<b>80</b>	5876	Ralla	Washer	Scheibe	Butée
<b>80 - 90</b>	456	Cappello chiuso	Cap cover	Geschlossener Deckel	Capuchon fermé
	5472	Vite di fissaggio	Fixing screw	Befestigungsschraube	Vis de fixation
	5473	Anello O-Ring	O-ring seal	O-Ring	Bague O-ring
<b>H</b>					
<b>60 - 70 - 80 - 90</b>	872	Ralla albero lento	Assembly ring	Scheibe der abtriebswelle	Boutée arbre lent
	5871	Anello seeger	Circlip	Seegerring	Seeger
<b>R</b>					
<b>60 - 70 - 80 - 90</b>	951	Albero lento	Output shaft	Abtriebswelle	Arbre lent
	952	Rondella albero lento	Washer	Scheibe der Abtriebswelle	Boutée arbre lent
	5871	Anello seeger	Circlip	Seegerring	Seeger
	5951	Vite di fissaggio	Screw	Befestigungsschraube	Vis de fixation
	5952	Linguetta	Key	Paßfeder	Clavette
	5953	Linguetta	Key	Paßfeder	Clavette
	5954	Rosetta	Washer	Scheibe	Rondelle
<b>S</b>					
<b>60 - 70 - 80 - 90</b>	873	Protezione calettatore	Safety cover	Schutzvorrichtung	Protection
	5873	Calettatore	Shrink disc	Schrumpfscheibe	Frette de serrage
	5874	Vite di fissaggio	Fixing screw	Befestigungsschraube	Vis de fixation
	5875	Rosetta zigrinata	Knurled washer	Rändelscheibe	Rondelle moletée
<b>HF - SF - RF</b>					
<b>60 - 70 - 80 - 90</b>	931	Flangia	Flange	Flansch	Bride
<b>H - S - R</b>					
<b>60 - 70 - 80 - 90</b>	881	Kit di fissaggio con boccia antivibrante	Anti-vibration kit	Dämpfungskit	Kit de fixation pour bras de réaction avec butée en caoutchouc
<b>AL - AR</b>					
<b>60</b>	601	Supporto antiretro	Anti-run-back support	Halter für Rückzugssperre	Douille antiretrait
	5501	Ruota libera	Free wheel	Freilauf	Roue libre
	5502	Anello seeger	Circlip	Seegerring	Seeger
	5503	Vite di fissaggio	Fixing screw	Befestigungsschraube	Vis de fixation
<b>70 - 80 - 90</b>	601	Supporto antiretro	Anti-run-back support	Halter für Rückzugssperre	Support anti-retrait
	5521	Ruota libera	Free wheel	Freilauf	Roue libre
	5522	Anello seeger	Circlip	Seegerring	Seeger
	5523	Vite di fissaggio	Fixing screw	Befestigungsschraube	Vis de fixation
	5525	Cuscinetto	Bearing	Kugellager	Roulement
<b>90</b>	603	Boccia per antiretro	Anti-run-back bushing	Buchse für Rückzugssperre	Douille antiretrait
	5524	Anello seeger	Circlip	Seegerring	Seeger

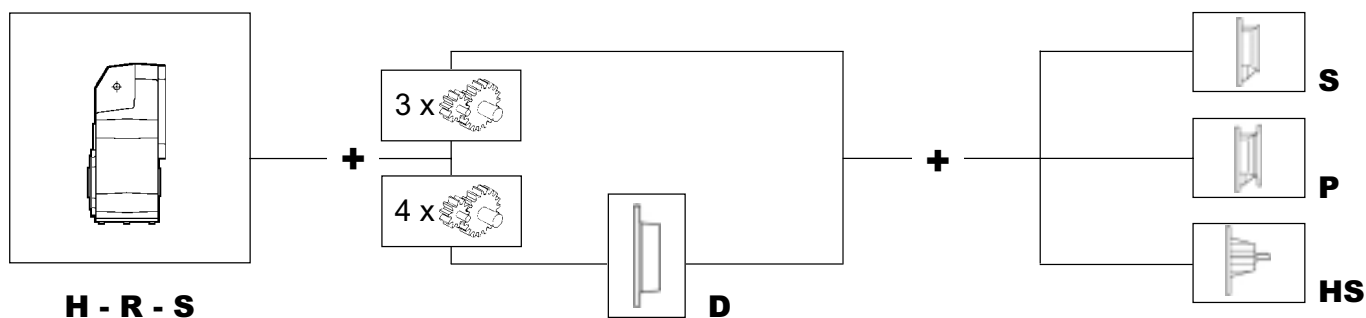

**8.0 MODULO  
ADDIZIONALE**

Il modulo addizionale viene interposto fra il modulo uscita del riduttore (C, A, F) e uno dei moduli entrata (paragrafo 9.0).

**8.0 ADDITIONAL  
GEAR MODULE**

The additional module is assembled between the output module of the gearbox (C, A, F) and one of the input modules (section 9.0).

**8.0 ZUSÄTZLICHE  
BAUEINHEIT**

Die zusätzliche Baueinheit wird zwischen die Ausgangseinheit des Getriebes (C, A, F) und eine der Baueinheiten mit (siehe Abschnitt 9.0) eingefügt.

**8.0 MODULE  
ADDITIONNEL**

Le module additionnel est interposé entre le module de sortie du réducteur (C, A, F) et un des modules d'entrée (paragraphe 9.0).

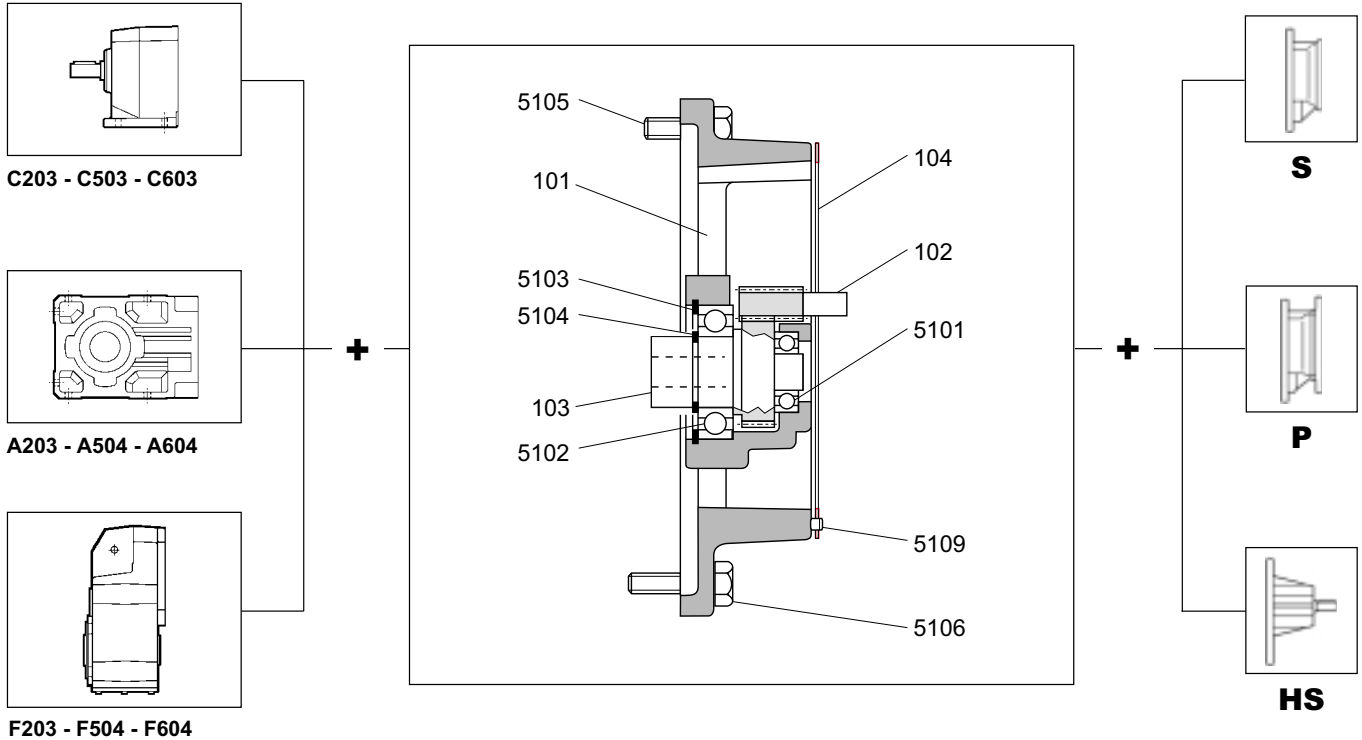

Quando le entrate S,P,HS devono essere fissate alle casse o ai moduli addizionali, le viti di fissaggio, nel caso in cui si trovino in corrispondenza di fori passanti devono avere il trattamento "DRILLOC" sul filetto. Se non è possibile reperirle, è indispensabile effettuare un'efficace sigillatura applicando un adeguato prodotto (Loctite 574) sul filetto all'atto del montaggio.



S (integr. motor), P (IEC motor interface), or HS (free shaft) input kits are to be fitted onto the main gear housings or to the additional gear module. Should fasteners engage into through holes, the threads of the former must be "DRILLOC" treated for sealing purposes. If such screws are not available locally, we recommend to apply Loctite 574, or an equivalent product, on the threads before connecting the parts.



Sollten die Antriebe S,P,HS an den Gehäusen oder den zusätzlichen Einheiten befestigt werden, muß auf die Gewinde der Schrauben 5002, 5027, und 5047, falls sie in den durchgehenden Bohrungen angeordnet sein sollten, "DRILLOC" aufgetragen werden. Sollte dieses Mittel nicht erhältlich sein, muß bei der Montage durch das Auftragen eines geeigneten Produkts (Loctite 574) auf das Gewinde, eine haltbare Sicherung gewährleistet werden.



Lorsque les entrées S,P,HS doivent être fixées aux carter ou aux modules additionnels, les vis de fixation, lorsqu'elles se trouvent en face des orifices passants, doivent être traitées avec "DRILLOC" au niveau du filetage. Si ce produit n'est pas disponible, au moment du montage, il est indispensable d'effectuer un scellement efficace en appliquant un produit spécifique (Loctite 574) sur le filetage.

C_, A_, F_	ref.				
<b>20 - 50 - 60</b>	101	Modulo addizionale	<i>Gear housing</i>	Zusatzbaueinheit	<i>Module additionnel</i>
	102	Pignone modulo addizionale	<i>Pinion shaft</i>	Ritzel für Zusatzbaueinheit	<i>Pignon module additionnel</i>
	103	Corona modulo addizionale	<i>Gear</i>	Zahnrad für Zusatzbaueinheit	<i>Couronne module additionnel</i>
	104	Guarnizione	<i>Gasket</i>	Dichtung	<i>Bague d'étanchéité</i>
	5101	Cuscinetto	<i>Bearing</i>	Kugellager	<i>Roulement</i>
	5102	Cuscinetto	<i>Bearing</i>	Kugellager	<i>Roulement</i>
	5103	Anello seeger	<i>Circlip</i>	Seegerring	<i>Seeger</i>
	5104	Anello seeger	<i>Circlip</i>	Seegerring	<i>Seeger</i>
	5105	Vite di fissaggio	<i>Fixing Screw</i>	Befestigungsschraube	<i>Vis de fixation</i>
	5106	Vite di fissaggio	<i>Fixing Screw</i>	Befestigungsschraube	<i>Vis de fixation</i>
5109	Spina cilindrica	<i>Dowel pin</i>	Zylinderstift	<i>Goupille cylindrique</i>	

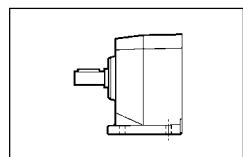

**C303**

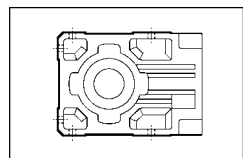

**A303**

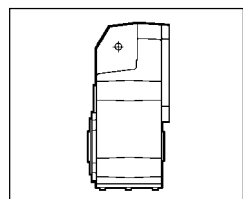

**F304**

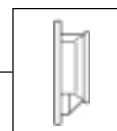
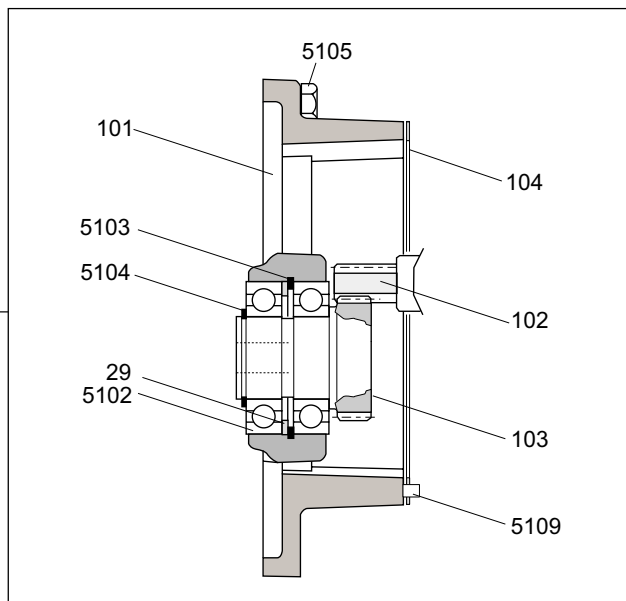

**S**

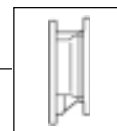

**P**

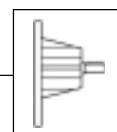

**HS**

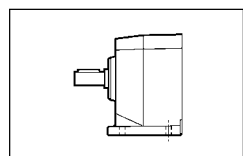

**C403**

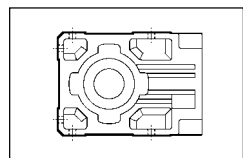

**A413**

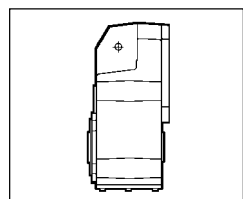

**F404**

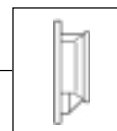
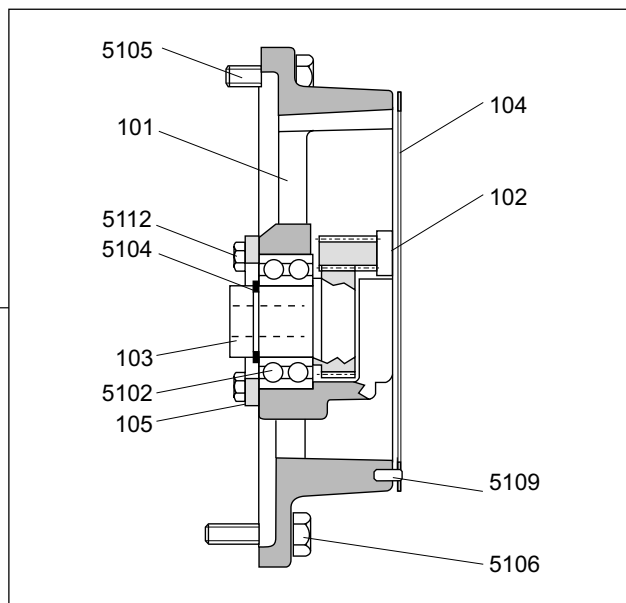

**S**

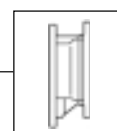

**P**

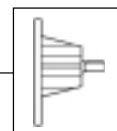

**HS**

C_, A_, F_	ref.				
<b>30 - 40</b>	101	Modulo addizionale	<i>Gear housing</i>	Zusatzbaueinheit	<i>Module additionnel</i>
	102	Pignone modulo addizionale	<i>Pinion shaft</i>	Ritzel für Zusatzbaueinheit	<i>Pignon module additionnel</i>
	103	Corona modulo addizionale	<i>Gear</i>	Zahnrad für Zusatzbaueinheit	<i>Couronne module additionnel</i>
	104	Guarnizione	<i>Gasket</i>	Dichtung	<i>Bague d'étanchéité</i>
	5102	Cuscinetto	<i>Bearing</i>	Kugellager	<i>Roulement</i>
	5104	Anello seeger	<i>Circlip</i>	Seegerring	<i>Seeger</i>
	5105	Vite di fissaggio	<i>Fixing Screw</i>	Befestigungsschraube	<i>Vis de fixation</i>
5109	Spina cilindrica	<i>Dowel pin</i>	Zylinderstift	<i>Goupille cylindrique</i>	
<b>30</b>	5103	Anello seeger	<i>Circlip</i>	Seegerring	<i>Seeger</i>
	29	Ralla	<i>Washer</i>	Scheibe	<i>Butée</i>
<b>40</b>	105	Anello di chiusura	<i>Closing ring</i>	Schlußring	<i>Bague de fermeture</i>
	5106	Vite di fissaggio	<i>Fixing Screw</i>	Befestigungsschraube	<i>Vis de fixation</i>
	5112	Vite di fissaggio	<i>Fixing screw</i>	Befestigungsschraube	<i>Vis de fixation</i>

Il modulo addizionale viene interposto fra il modulo uscita del riduttore (C, A, F) e uno dei moduli entrata (paragrafo 9.0).

The additional module is fitted between the output module of the gearbox (C, A, F) and one of the input modules (section 9.0).

Die zusätzliche Baueinheit wird zwischen die Ausgangseinheit des Getriebes (C, A, F) und eine der Baueinheiten mit (siehe Abschnitt 9.0) eingefügt.

Le module additionnel est interposé entre le module de sortie du réducteur (C, A, F) et un des modules d'entrée (paragraphe 9.0).

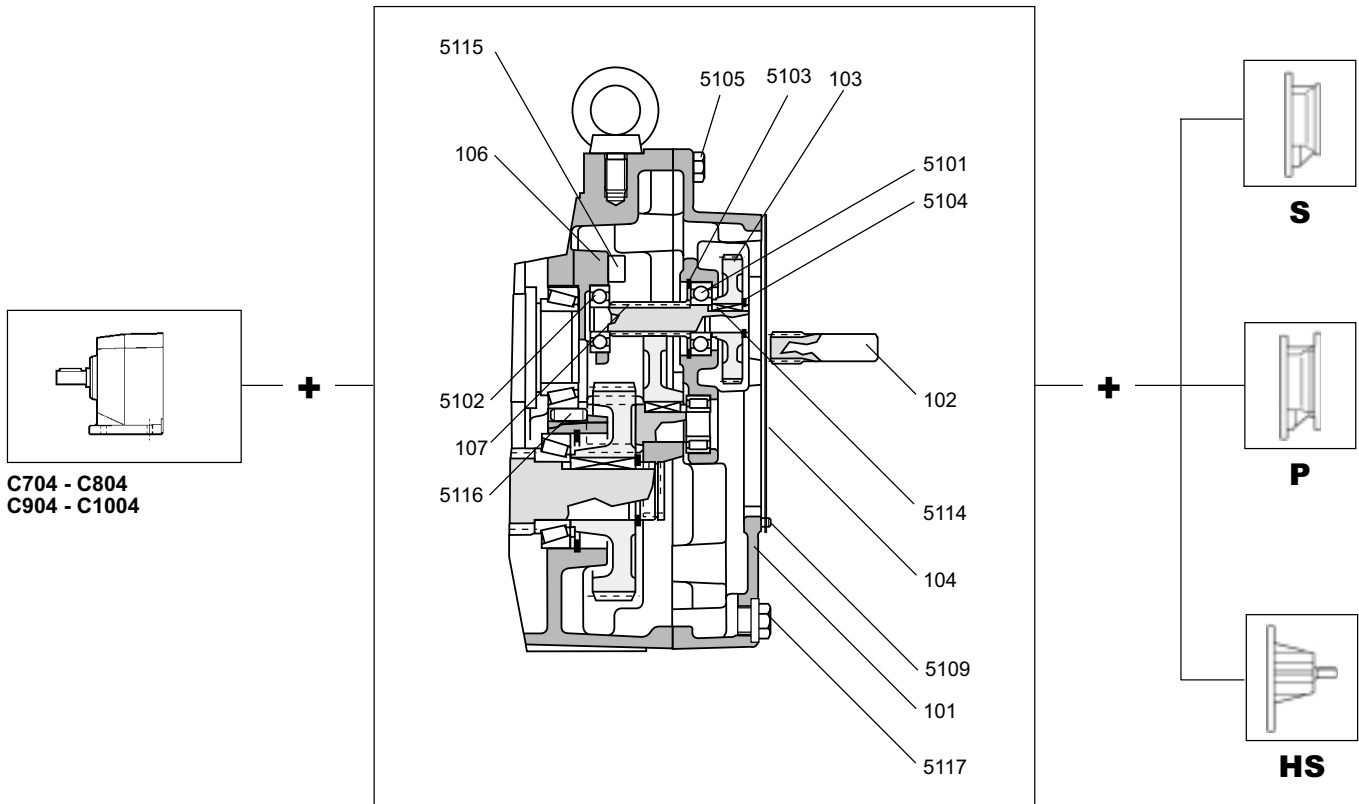

Quando le entrate S,P,HS devono essere fissate alle casse o ai moduli addizionali, le viti di fissaggio, nel caso in cui si trovino in corrispondenza di fori passanti devono avere il trattamento "DRILLOC" sul filetto. Se non è possibile reperirle, è indispensabile effettuare un'efficace sigillatura applicando un adeguato prodotto (Loctite 574) sul filetto all'atto del montaggio.



S (integr. motor), P (IEC motor interface), or HS (free shaft) input kits are to be fitted onto the main gear housings or to the additional gear module. Should fasteners engage into through holes, the threads of the former must be "DRILLOC" treated for sealing purposes. If such screws are not available locally, we recommend to apply Loctite 574, or an equivalent product, on the threads before connecting the parts.



Sollten die Antriebe S,P,HS an den Gehäusen oder den zusätzlichen Einheiten befestigt werden, muß auf die Gewinde der Schrauben 5002, 5027, und 5047, falls sie in den durchgehenden Bohrungen angeordnet sein sollten, "DRILLOC" aufgetragen werden. Sollte dieses Mittel nicht erhältlich sein, muß bei der Montage durch das Auftragen eines geeigneten Produkts (Loctite 574) auf das Gewinde, eine haltbare Sicherung gewährleistet werden.



Lorsque les entrées S,P,HS doivent être fixées aux carter ou aux modules additionnels, les vis de fixation, lorsqu'elles se trouvent en face des orifices passants, doivent être traitées avec "DRILLOC" au niveau du filetage. Si ce produit n'est pas disponible, au moment du montage, il est indispensable d'effectuer un scellement efficace en appliquant un produit spécifique (Loctite 574) sur le filetage.

C_	ref.				
70 - 80 90 - 100	101	Modulo addizionale	Gear housing	Zusatzbaueinheit	Module additionnel
	102	Pignone modulo addizionale	Pinion shaft	Ritzel für Zusatzbaueinheit	Pignon module additionnel
	103	Corona modulo addizionale	Gear	Zahnrad für Zusatzbaueinheit	Couronne module additionnel
	104	Guarnizione	Gasket	Dichtung	Bague d'étanchéité
	106	Supporto cuscinetto	Bearing support	Lageraufnahme	Support roulement
	107	Pignone 1° mod.D	Pinion shaft	Ritzel 1 Mod. D	Pignon 1 mod. D
	5101	Cuscinetto	Bearing	Kugellager	Roulement
	5102	Cuscinetto	Bearing	Kugellager	Roulement
	5103	Anello seeger	Circlip	Seegerring	Seeger
	5104	Anello seeger	Circlip	Seegerring	Seeger
	5105	Vite di fissaggio	Fixing Screw	Befestigungsschraube	Vis de fixation
	5109	Spina cilindrica	Dowel pin	Zylinderstift	Goupille cylindrique
	5114	Linguetta	Key	Paßfeder	Clavette
	5115	Vite di fissaggio	Fixing screw	Befestigungsschraube	Vis de fixation
	5117	Tappo olio	Oil plug	Ölverschluß	Bouchon d'huile
70 - 80	5116	Spina elastica	Dowel pin	Zylinderstift	Goupille cylindrique

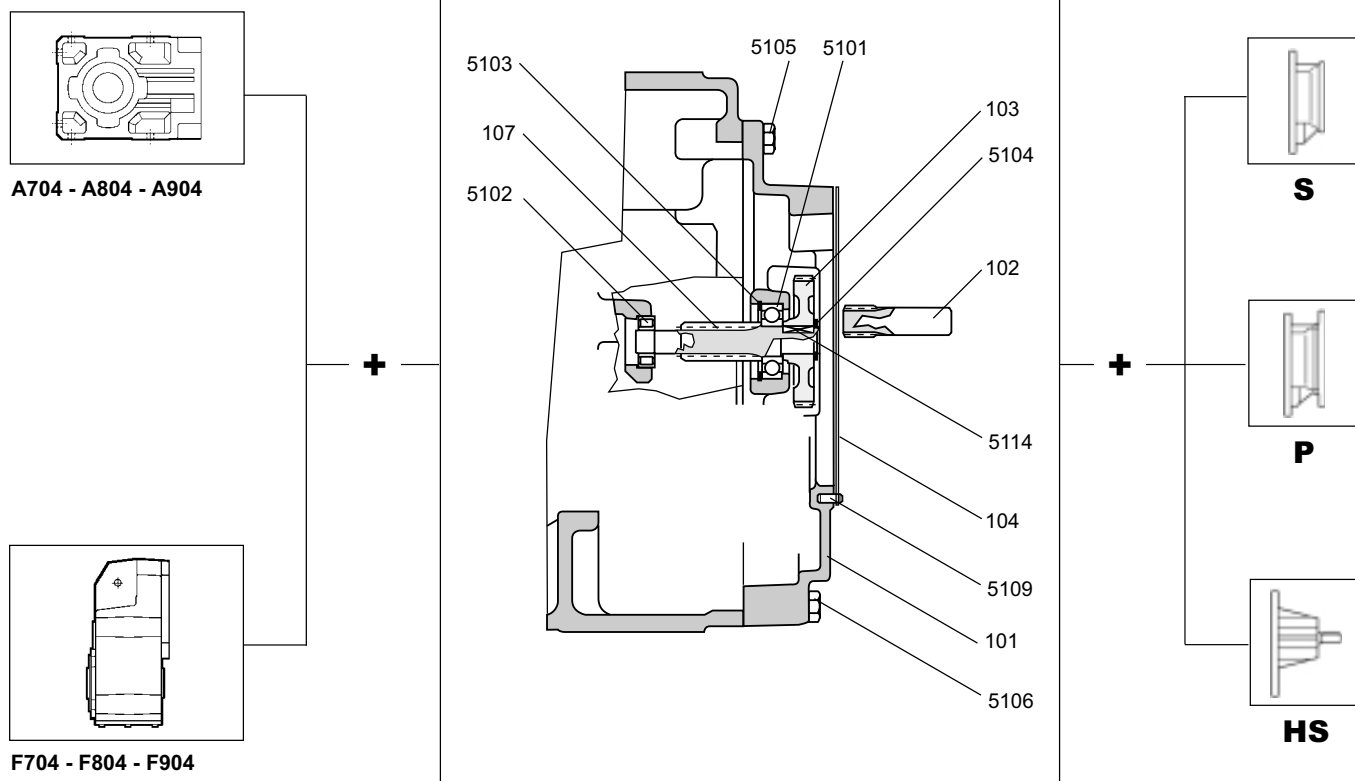

**!** Quando le entrate S,P,HS devono essere fissate alle casse o ai moduli addizionali, le viti di fissaggio, nel caso in cui si trovino in corrispondenza di fori passanti devono avere il trattamento "DRILLOC" sul filetto. Se non è possibile reperirle, è indispensabile effettuare un'efficace sigillatura applicando un adeguato prodotto (Loctite 574) sul filetto all'atto del montaggio.

**!** S (integr. motor), P (IEC motor interface), or HS (free shaft) input kits are to be fitted onto the main gear housings or to the additional gear module. Should fasteners engage into through holes, the threads of the former must be "DRILLOC" treated for sealing purposes. If such screws are not available locally, we recommend to apply Loctite 574, or an equivalent product, on the threads before connecting the parts.

**!** Sollten die Antriebe S,P,HS an den Gehäusen oder den zusätzlichen Einheiten befestigt werden, muß auf die Gewinde der Schrauben 5002, 5027, und 5047, falls sie in den durchgehenden Bohrungen angeordnet sein sollten, "DRILLOC" aufgetragen werden. Sollte dieses Mittel nicht erhältlich sein, muß bei der Montage durch das Auftragen eines geeigneten Produkts (Loctite 574) auf das Gewinde, eine haltbare Sicherung gewährleistet werden.

**!** Lorsque les entrées S,P,HS doivent être fixées aux carter ou aux modules additionnels, les vis de fixation, dans le cas où elles se trouvent en face des orifices passants, doivent être traitées avec "DRILLOC" au niveau du filetage. Si ce produit n'est pas disponible, au moment du montage, il est indispensable d'effectuer un scellement efficace en appliquant un produit spécifique (Loctite 574) sur le filetage.

A_ F_	ref.				
70 - 80 - 90	101	Modulo addizionale	<i>Gear housing</i>	Zusatzbaueinheit	<i>Module additionnel</i>
	102	Pignone modulo addizionale	<i>Pinion shaft</i>	Ritzel für Zusatzbaueinheit	<i>Pignon module additionnel</i>
	103	Corona modulo addizionale	<i>Gear</i>	Zahnrad für Zusatzbaueinheit	<i>Couronne module additionnel</i>
	104	Guarnizione	<i>Gasket</i>	Dichtung	<i>Bague d'étanchéité</i>
	106	Supporto cuscinetto	<i>Bearing support</i>	Lageraufnahme	<i>Support roulement</i>
	107	Pignone 1° mod.D	<i>Pinion shaft</i>	Ritzel 1 Mod. D	<i>Pignon 1 mod. D</i>
	5101	Cuscinetto	<i>Bearing</i>	Kugellager	<i>Roulement</i>
	5102	Cuscinetto	<i>Bearing</i>	Kugellager	<i>Roulement</i>
	5103	Anello seeger	<i>Circlip</i>	Seegerring	<i>Seeger</i>
	5104	Anello seeger	<i>Circlip</i>	Seegerring	<i>Seeger</i>
	5105	Vite di fissaggio	<i>Fixing Screw</i>	Befestigungsschraube	<i>Vis de fixation</i>
	5106	Vite di fissaggio	<i>Fixing Screw</i>	Befestigungsschraube	<i>Vis de fixation</i>
	5109	Spina cilindrica	<i>Dowel pin</i>	Zylinderstift	<i>Goupille cylindrique</i>
	5114	Linguetta	<i>Key</i>	Paßfeder	<i>Clavette</i>

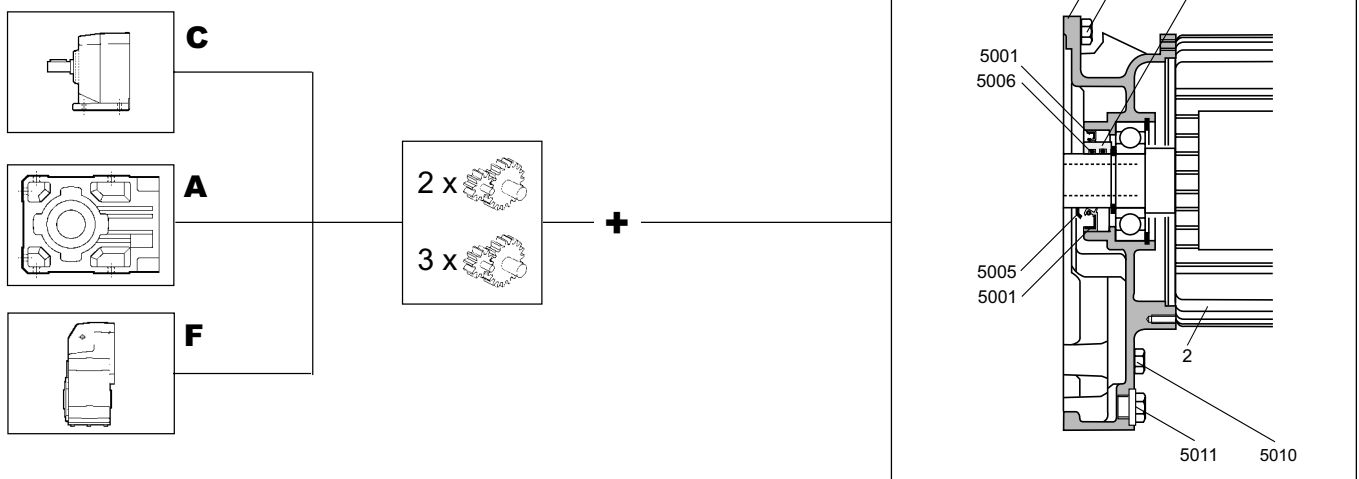
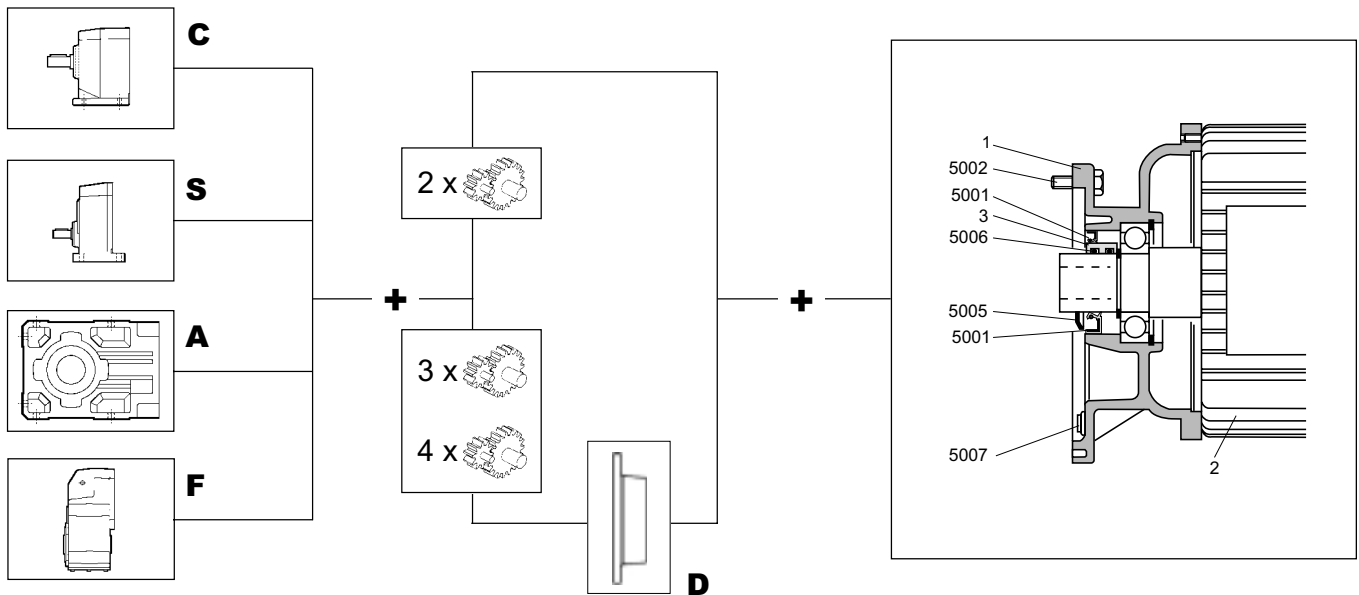

Quando le entrate S,P,HS devono essere fissate alle casse o ai moduli addizionali, le viti di fissaggio, nel caso in cui si trovino in corrispondenza di fori passanti devono avere il trattamento "DRILLOC" sul filetto. Se non è possibile reperirle, è indispensabile effettuare un'efficace sigillatura applicando un adeguato prodotto (Loctite 574) sul filetto all'atto del montaggio.



S (integr. motor), P (IEC motor interface), or HS (free shaft) input kits are to be fitted onto the main gear housings or to the additional gear module. Should fasteners engage into through holes, the threads of the former must be "DRILLOC" treated for sealing purposes. If such screws are not available locally, we recommend to apply Loctite 574, or an equivalent product, on the threads before connecting the parts.



Sollten die Antriebe S,P,HS an den Gehäusen oder den zusätzlichen Einheiten befestigt werden, muß auf die Gewinde der Schrauben 5002, 5027, und 5047, falls sie in den durchgehenden Bohrungen angeordnet sein sollten, "DRILLOC" aufgetragen werden. Sollte dieses Mittel nicht erhältlich sein, muß bei der Montage durch das Auftragen eines geeigneten Produkts (Loctite 574) auf das Gewinde, eine haltbare Sicherung gewährleistet werden.



Lorsque les entrées S,P,HS doivent être fixées aux carter ou aux modules additionnels, les vis de fixation, lorsqu'elles se trouvent en face des orifices passants, doivent être traitées avec "DRILLOC" au niveau du filetage. Si ce produit n'est pas disponible, au moment du montage, il est indispensable d'effectuer un scellement efficace en appliquant un produit spécifique (Loctite 574) sur le filetage.

S_(C_, A_, S_, F_)	ref.				
<b>M1 - M2 - M3 - M4 - M5</b>	1	Flangia motore compatto	Compact motor flange	Flansch des kompakten Motors	Bride moteur compact
	2	Motore compatto	Compact motor	Kompakter Motor	Moteur compact
	3	Boccola per anello di tenuta	Oil seal bushing	Buchse für Dichtungsringe	Douille pour joint d'étanchéité
	5001	Anello di tenuta	Oil seal	Simmerring	Bague d'étanchéité
	5002	Vite di fissaggio	Fixing screw	Befestigungsschraube	Vis de fixation
<b>M3 - M4 - M5</b>	5005	Gamma seals	Gamma ring	Gamma - Ring	Défecteur
	5007	Tappo olio	Oil plug	Ölverschluß	Bouchon d'huile
<b>M2 - M3 - M4 - M5</b>	5006	Anello O-ring	O-ring seal	O-Ring	Bague O-ring
	5010	Vite di fissaggio	Fixing screw	Befestigungsschraube	Vis de fixation
	5011	Tappo olio	Oil plug	Ölverschluß	Bouchon d'huile

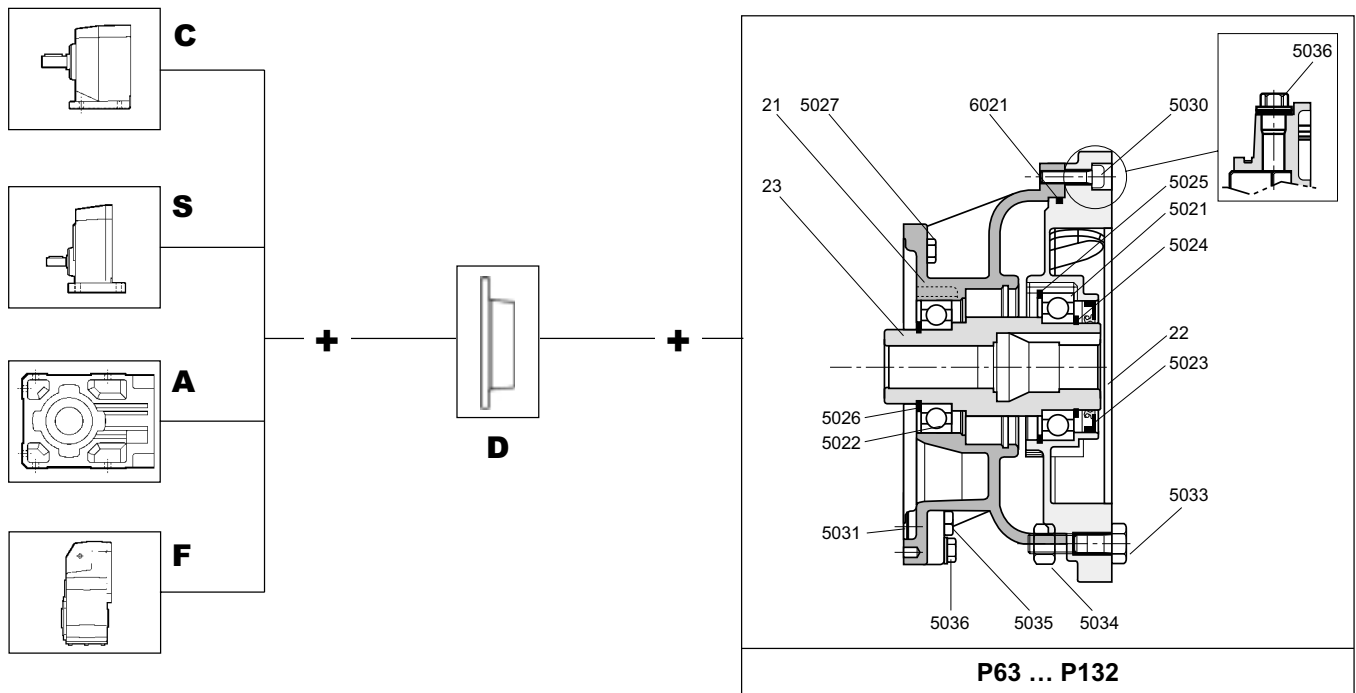

P63 ... P132

**!** Quando le entrate S,P,HS devono essere fissate alle casse o ai moduli addizionali, le viti di fissaggio, nel caso in cui si trovino in corrispondenza di fori passanti devono avere il trattamento "DRILOLOC" sul filetto. Se non è possibile reperirle, è indispensabile effettuare un'efficace sigillatura applicando un adeguato prodotto (Loctite 574) sul filetto all'atto del montaggio.

**!** S (integr. motor), P (IEC motor interface), or HS (free shaft) input kits are to be fitted onto the main gear housings or to the additional gear module. Should fasteners engage into through holes, the threads of the former must be "DRILOLOC" treated for sealing purposes. If such screws are not available locally, we recommend to apply Loctite 574, or an equivalent product, on the threads before connecting the parts.

**!** Sollten die Antriebe S,P,HS an den Gehäusen oder den zusätzlichen Einheiten befestigt werden, muß auf die Gewinde der Schrauben 5002, 5027, und 5047, falls sie in den durchgehenden Bohrungen angeordnet sein sollten, "DRILOLOC" aufgetragen werden. Sollte dieses Mittel nicht erhältlich sein, muß bei der Montage durch das Auftragen eines geeigneten Produkts (Loctite 574) auf das Gewinde, eine haltbare Sicherung gewährleistet werden.

**!** Lorsque les entrées S,P,HS doivent être fixées aux carter ou aux modules additionnels, les vis de fixation, lorsqu'elles se trouvent en face des orifices passants, doivent être traitées avec "DRILOLOC" au niveau du filetage. Si ce produit n'est pas disponible, au moment du montage, il est indispensable d'effectuer un scellement efficace en appliquant un produit spécifique (Loctite 574) sur le filetage.

P_ (C_, S_, A_, F_)	ref.				
P63 ... P132	21	Flangia motore	Main flange	Motorflansch	Bride moteur
	22	Controflangia IEC	IEC interface	IEC-Flansch	Bride
	23	Albero veloce	Input shaft	Antriebswelle	Arbre rapide
	5021	Cuscinetto	Bearing	Kugellager	Roulement
	5022	Cuscinetto	Bearing	Kugellager	Roulement
	5023	Anello di tenuta	Oil seal	Simmerring	Bague d'étanchéité
	5024	Anello seeger	Circlip	Seegerring	Seeger
	5025	Anello seeger	Circlip	Seegerring	Seeger
	5026	Anello seeger	Circlip	Seegerring	Seeger
	5027	Vite di fissaggio	Fixing screw	Befestigungsschraube	Vis de fixation
	5030	Vite di fissaggio	Fixing screw	Befestigungsschraube	Vis de fixation
	5031	Tappo olio	Oil plug	Ölverschluß	Bouchon d'huile
	5033	Vite di fissaggio	Fixing screw	Befestigungsschraube	Vis de fixation
	5034	Dado	Nut	Mutter	Ecrou
	5035	Vite di fissaggio	Fixing screw	Befestigungsschraube	Vis de fixation
	5036	Tappo olio	Oil plug	Ölverschluß	Bouchon d'huile
	5040	Anello Seeger	Circlip	Seegerring	Seeger

**Posizione tappo olio su flangia  
attacco motore**

**Breather plug location onto  
motor mounting flange**

**Position der Ölschraube am  
Motoranschlussflansch**

**Position bouchon d'huile sur  
bride de fixation moteur**

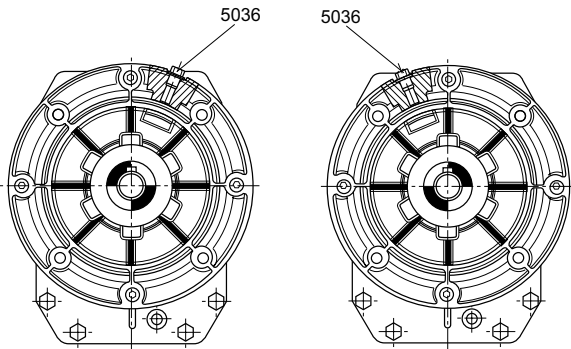

**P63 ... P112**

**P132**

Tipo - Type Typ - Type	Posizioni di montaggio - Mounting Positions Einbaulagen - Positions de montage
A	B3 - VA - VB
C (P-UP-UPF)	B3 - V5 - V6
C (F-UF-U)	B5 - V1 - V3
F	H1 - H5 - H6
S (P)	B3 - V5 - V6
S (F)	B5 - V1 - V3

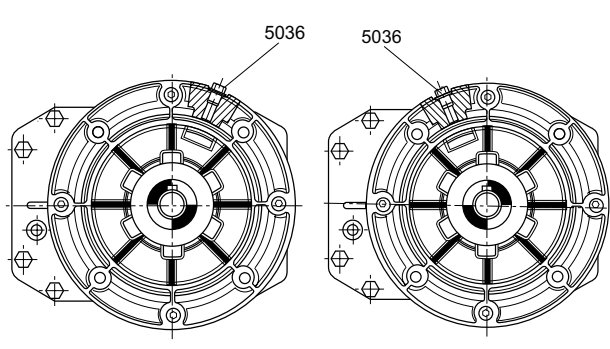

**P 63 ... P112**

**P132**

Tipo - Type Typ - Type	Posizioni di montaggio - Mounting Positions Einbaulagen - Positions de montage
A	B7
C (P-UP-UPF)	B7
F	H3
S (P)	B7
S (F)	B53

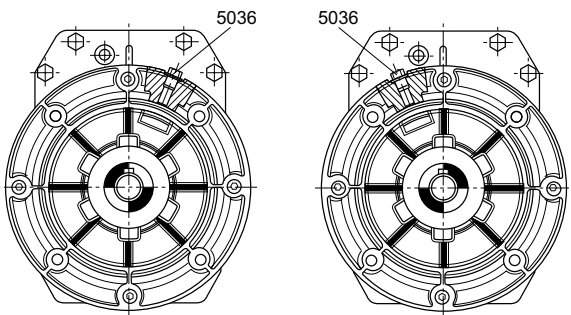

**P63 ... P112**

**P132**

Tipo - Type Typ - Type	Posizioni di montaggio - Mounting Positions Einbaulagen - Positions de montage
A	B8
C (P-UP-UPF)	B8
F	H2
S (P)	B8
S (F)	B52

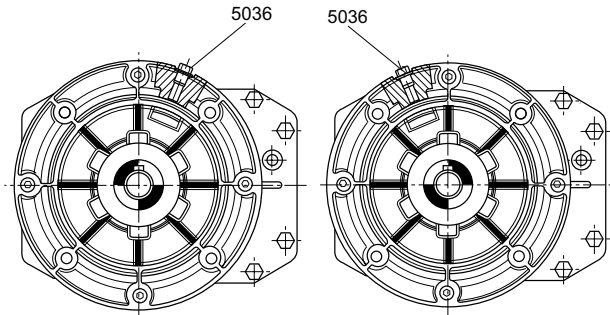

**P63 ... P112**

**P132**

Tipo - Type Typ - Type	Posizioni di montaggio - Mounting Positions Einbaulagen - Positions de montage
A	B6
C (P-UP-UPF)	B6
F	H4
S (P)	B6
S (F)	B51

**Note:**

Sostituire il tappo chiuso con il tappo di sfiato fornito in acceordone nei seguenti casi:

**Note:**

Replace the closed plug with the breather plug supplied in the following cases:

**Hinweis:**

Den mitgelieferten Ablassverschlussstopfen in den folgenden Fällen verwenden:

**Remarques:**

Remplacer le bouchon fermé par le bouchon de vidange livré en dotation dans les cas suivants :

Tipo - Type - Typ - Type	Posizioni di montaggio - Mounting Positions Einbaulagen - Positions de montage
A 102, A 202-A 203, A 302-A 303	B3 - B8 - B6 - B7 - VA
A 403, A 504, A 604, A 704, A 804, A 904	VA
C 102, C 202-C 203, C 302-C 303, C 402-C 403, C 502-C 503	B3 - B8 - B6 - B7 - V5 - V1 - B5 - B51 - B52 - B53
C 603, C 704, C 804, C 904, C 1004	V5 - V1
F 102, F 202-F 203, F 302-F 303-F 304	H1 - H3 - H4 - H5
F 404, F 504, F 604, F 704, F 804, F 904	H5
S 101, S 201, S 301, S 401	B3 - B6 - B7 - B8 - V5 - B5 - B52 - V1 - B51 - B53
S 501	V1 - V5

In tutti gli altri casi mantenere il tappo chiuso.

In all the other cases leave the closed plug into position.

In allen anderen Fällen, den Verschluss geschlossen lassen.

Dans les autres cas, garder le bouchon fermé.

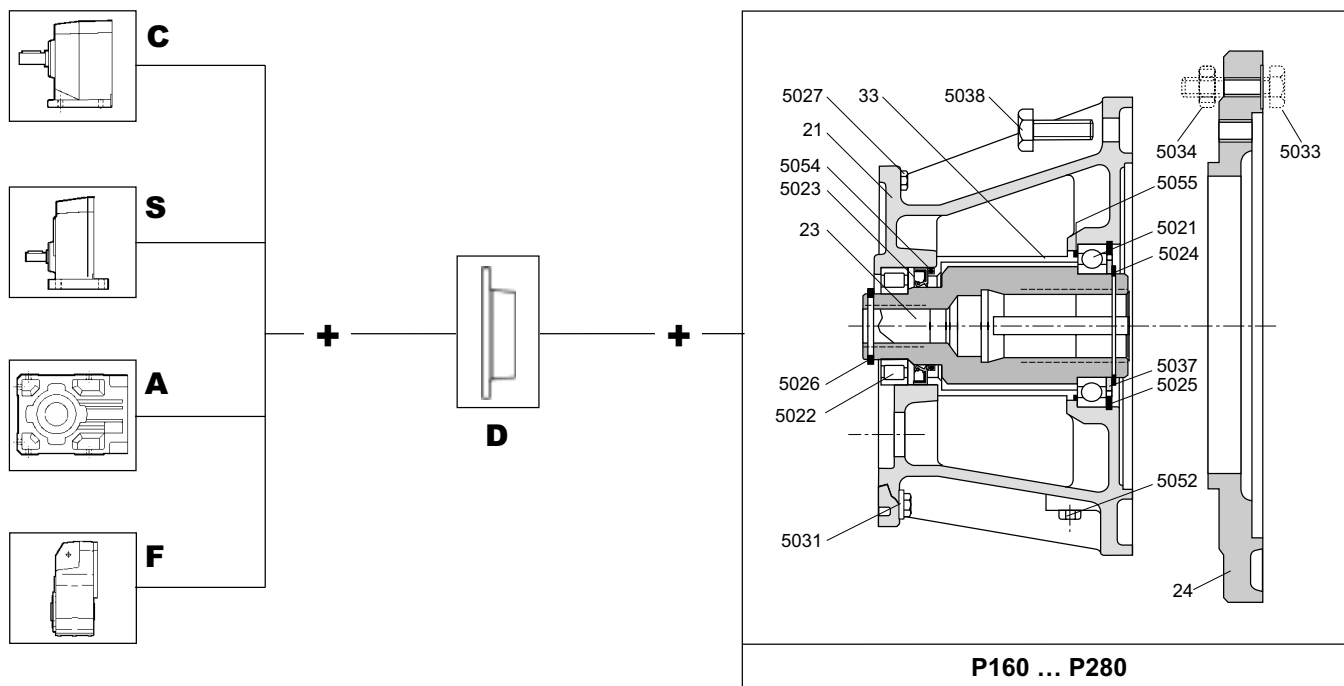

**!** Quando le entrate S,P,HS devono essere fissate alle casse o ai moduli addizionali, le viti di fissaggio, nel caso in cui si trovino in corrispondenza di fori passanti devono avere il trattamento "DRILLOC" sul filetto. Se non è possibile reperirle, è indispensabile effettuare un'efficace sigillatura applicando un adeguato prodotto (Loctite 574) sul filetto all'atto del montaggio.

**!** S (integr. motor), P (IEC motor interface), or HS (free shaft) input kits are to be fitted onto the main gear housings or to the additional gear module. Should fasteners engage into through holes, the threads of the former must be "DRILLOC" treated for sealing purposes. If such screws are not available locally, we recommend to apply Loctite 574, or an equivalent product, on the threads before connecting the parts.

**!** Sollten die Antriebe S,P,HS an den Gehäusen oder den zusätzlichen Einheiten befestigt werden, muß auf die Gewinde der Schrauben 5002, 5027, und 5047, falls sie in den durchgehenden Bohrungen angeordnet sein sollten, "DRILLOC" aufgetragen werden. Sollte dieses Mittel nicht erhältlich sein, muß bei der Montage durch das Auftragen eines geeigneten Produkts (Loctite 574) auf das Gewinde, eine haltbare Sicherung gewährleistet werden.

**!** Lorsque les entrées S,P,HS doivent être fixées aux carter ou aux modules additionnels, les vis de fixation, lorsqu'elles se trouvent en face des orifices passants, doivent être traitées avec "DRILLOC" au niveau du filetage. Si ce produit n'est pas disponible, au moment du montage, il est indispensable d'effectuer un scellement efficace en appliquant un produit spécifique (Loctite 574) sur le filetage.

P_ (C_, S_, A_, F_)	ref.				
<b>P160 ... P280</b>	21	Flangia motore	Main motor flange	Motorflansch	Bride moteur
	23	Albero veloce	Input shaft	Antriebswelle	Arbre d'entrée
<b>P200 - P250 - P280</b>	24	Controflangia IEC	IEC interface	Flansch	Bride
<b>P160 ... P280</b>	5021	Cuscinetto	Bearing	Kugellager	Roulement
	5022	Cuscinetto	Bearing	Kugellager	Roulement
	5023	Anello di tenuta	Oil seal	Simmgerring	Bague d'étanchéité
	5024	Anello seeger	Circlip	Seegerring	Seeger
	5025	Anello seeger	Circlip	Seegerring	Seeger
	5026	Anello seeger	Circlip	Seegerring	Seeger
	5027	Vite di fissaggio	Fixing screw	Befestigungsschraube	Vis de fixation
	5031	Tappo olio	Oil plug	Ölverschluß	Bouchon d'huile
<b>P160 - P180</b>	5033	Vite di fissaggio	Fixing screw	Befestigungsschraube	Vis de fixation
	5034	Dado	Nut	Mutter	Ecrou
<b>P160 - P180</b>	5037	Ralla	Washer	Scheibe	Butée
<b>P200 - P250 - P280</b>	5038	Vite di fissaggio	Fixing screw	Befestigungsschraube	Vis de fixation
<b>P160 ... P280</b>	5035	Vite di fissaggio	Fixing screw	Befestigungsschraube	Vis de fixation
	5036	Tappo olio	Oil plug	Ölverschluß	Bouchon d'huile
	5040	Anello seeger	Circlip	Seegerring	Seeger
<b>P160 ... P250<sup>(*)</sup></b>	33	Boccola	Bushing	Buchse	Douille
	5052	Tappo olio	Oil plug	Ölverschluß	Bouchon d'huile
	5054	Anello O-ring	O-ring seal	O-ring	Bague O-ring
	5055	Anello O-ring	O-ring seal	O-ring	Bague O-ring

<sup>(\*)</sup> Solo per installazioni con motore dispostato in verticale.

<sup>(\*)</sup> Only for mounting positions with motor sitting vertically.

<sup>(\*)</sup> nur für Installationen mit senkrecht ausgerichteten Motor

<sup>(\*)</sup> Uniquement pour les installations équipées de moteur en position verticale

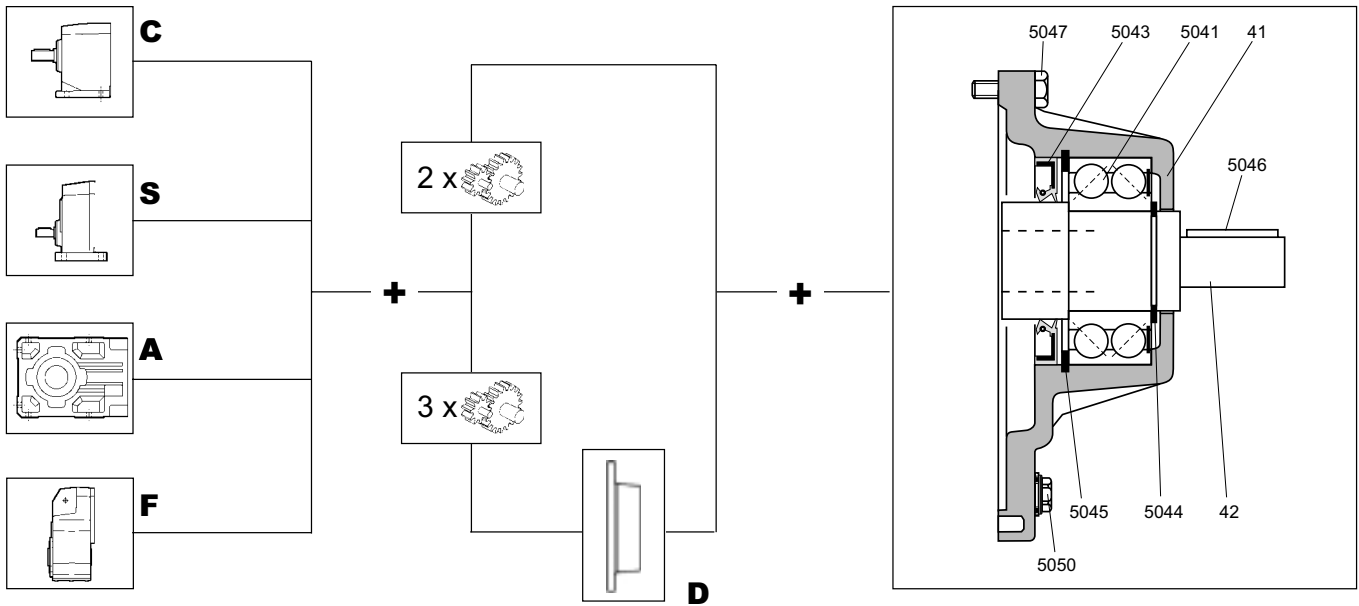

HS	ref.				
<b>C102 - 203 - 303</b>	41	Coperchio	<i>Cover</i>	Deckel	<i>Couvercle</i>
	42	Albero veloce	<i>Input shaft</i>	Antriebswelle	<i>Arbre d'entrée</i>
<b>S101</b>	5041	Cuscinetto	<i>Bearing</i>	Kugellager	<i>Roulement</i>
	5043	Anello di tenuta	<i>Oil seal</i>	Simmerring	<i>Bague d'étanchéité</i>
<b>A102 - 203 - 303</b>	5045	Anello seeger	<i>Circlip</i>	Seegerring	<i>Seeger</i>
	5046	Linguetta	<i>Key</i>	Paßfeder	<i>Clavette</i>
<b>F102 - 203 - 304</b>	5047	Vite di fissaggio	<i>Fixing screw</i>	Befestigungsschraube	<i>Vis de fixation</i>
	5044	Anello seeger	<i>Circlip</i>	Seegerring	<i>Seeger</i>
	5050	Tappo olio	<i>Oil plug</i>	Ölverschluß	<i>Bouchon d'huile</i>

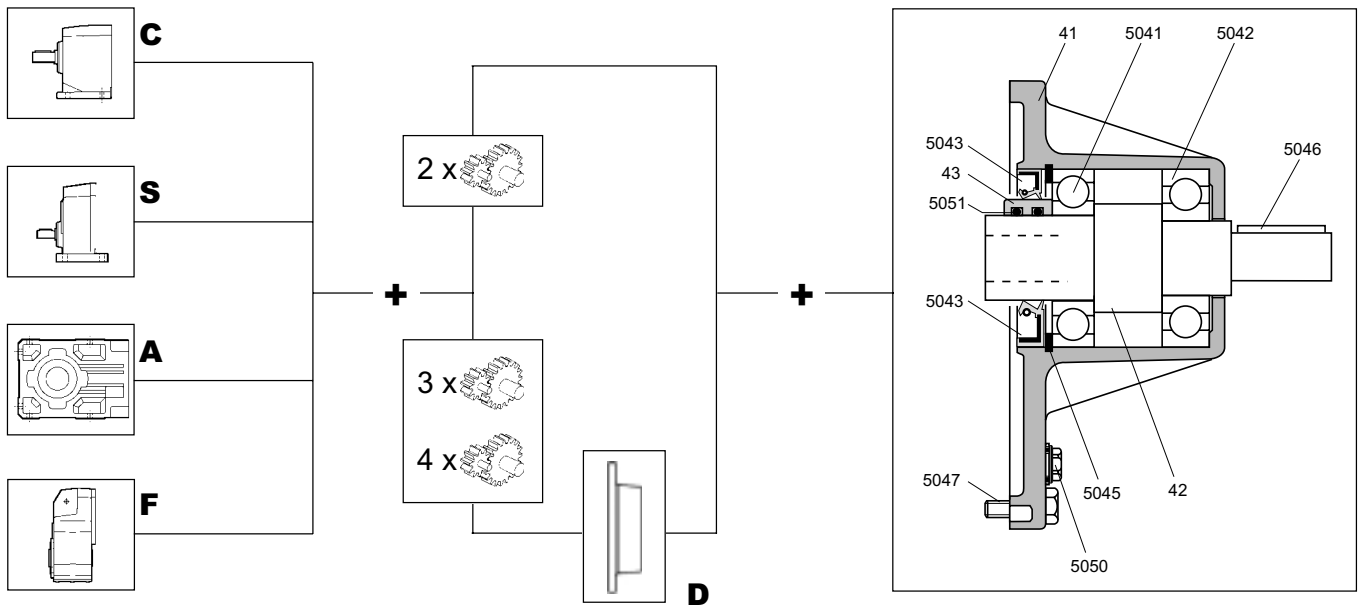

HS	ref.				
<b>C202 - 302 - 402 - 502</b>	41	Coperchio	<i>Cover</i>	Deckel	<i>Couvercle</i>
	42	Albero veloce	<i>Input shaft</i>	Antriebswelle	<i>Arbre d'entrée</i>
	43	Boccola per anello di tenuta	<i>Oilseal sleeve</i>	Buchse für Dichtungsringe	<i>Douille pour joint d'étanchéité</i>
<b>S201 - 301 - 401 - 501</b>	5041	Cuscinetto	<i>Bearing</i>	Kugellager	<i>Roulement</i>
	5042	Cuscinetto	<i>Bearing</i>	Kugellager	<i>Roulement</i>
<b>A202 - 302 - 412 - 502 - 503</b>	5043	Anello di tenuta	<i>Oil seal</i>	Simmerring	<i>Bague d'étanchéité</i>
	5045	Anello seeger	<i>Circlip</i>	Seegerring	<i>Seeger</i>
	5046	Linguetta	<i>Key</i>	Paßfeder	<i>Clavette</i>
<b>F202 - 302 - 303 - 402 - 403 - 502 - 503</b>	5047	Vite di fissaggio	<i>Fixing screw</i>	Befestigungsschraube	<i>Vis de fixation</i>
	5044	Anello seeger	<i>Circlip</i>	Seegerring	<i>Seeger</i>
	5050	Tappo olio	<i>Oil plug</i>	Ölverschluß	<i>Bouchon d'huile</i>
	5051	Anello O-ring	<i>O-ring seal</i>	O-Ring	<i>Bague O-ring</i>



Quando le entrate S,P,HS devono essere fissate alle casse o ai moduli addizionali, le viti di fissaggio, nel caso in cui si trovino in corrispondenza di fori passanti devono avere il trattamento "DRILOLOC" sul filetto. Se non è possibile reperirle, è indispensabile effettuare un'efficace sigillatura applicando un adeguato prodotto (Loctite 574) sul filetto all'atto del montaggio.



S (integr. motor), P (IEC motor interface), or HS (free shaft) input kits are to be fitted onto the main gear housings or to the additional gear module. Should fasteners engage into through holes, the threads of the former must be "DRILOLOC" treated for sealing purposes. If such screws are not available locally, we recommend to apply Loctite 574, or an equivalent product, on the threads before connecting the parts.



Sollten die Antriebe S,P,HS an den Gehäusen oder den zusätzlichen Einheiten befestigt werden, muß auf die Gewinde der Schrauben 5002, 5027, und 5047, falls sie in den durchgehenden Bohrungen angeordnet sein sollten, "DRILOLOC" aufgetragen werden. Sollte dieses Mittel nicht erhältlich sein, muß bei der Montage durch das Auftragen eines geeigneten Produkts (Loctite 574) auf das Gewinde, eine haltbare Sicherung gewährleistet werden.



Lorsque les entrée S,P,HS doivent être fixées aux carter ou aux modules additionnels, les vis de fixation, lorsqu'elles se trouvent en face des orifices passants, doivent être traitées avec "DRILOLOC" au niveau du filetage. Si ce produit n'est pas disponible, au moment du montage, il est indispensable d'effectuer un scellement efficace en appliquant un produit spécifique (Loctite 574) sur le filetage.

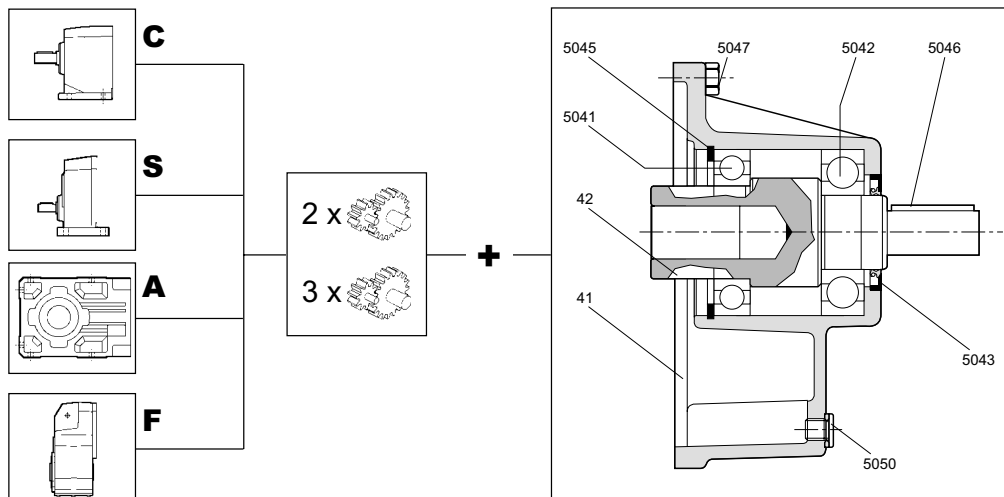

HS_	ref.			
<b>C602</b> <b>A602 - 603</b> <b>F603</b>	41	Coperchio	Cover	Deckel
	42	Albero veloce	Input shaft	Antriebswelle
	5041	Cuscinetto	Bearing	Kugellager
	5042	Cuscinetto	Bearing	Kugellager
	5043	Anello di tenuta	Oil seal	Simmering
	5045	Anello seeger	Circlip	Seegerring
	5046	Linguetta	Key	Paßfeder
	5047	Vite di fissaggio	Fixing screw	Befestigungsschraube
	5050	Tappo olio	Oil plug	Ölverschluß
				Arbre d'entrée
				Roulement
				Roulement
				Bague d'étanchéité
				Seeger
				Clavette
				Vis de fixation
				Bouchon d'huile

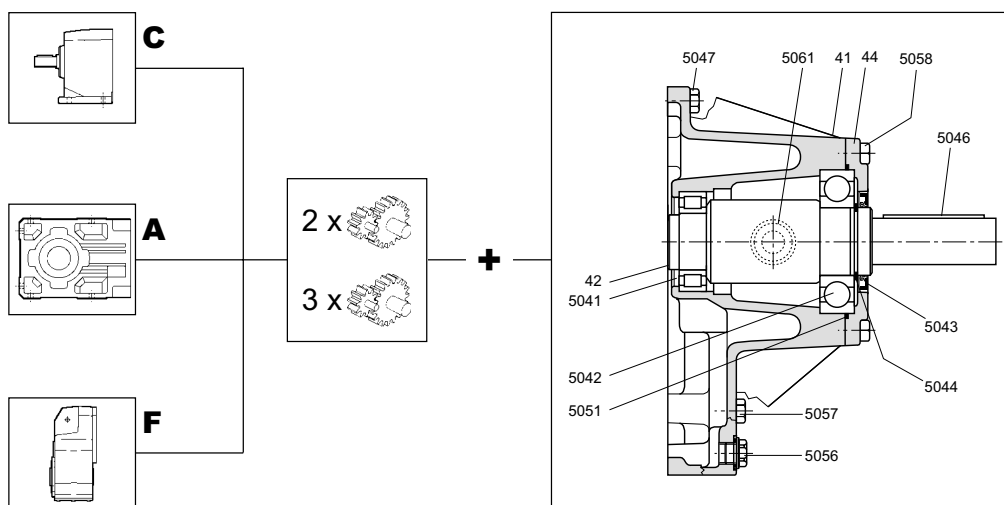

HS_	ref.			
<b>C702 - 703 - 802 - 803</b> <b>902 - 903 - 1002 - 1003</b> <b>A703 - 803 - 903</b> <b>F703 - 803 - 903</b>	41	Coperchio	Cover	Deckel
	42	Albero veloce	Input shaft	Antriebswelle
	44	Cappellotto	Cap	Deckel
	5041	Cuscinetto	Bearing	Kugellager
	5042	Cuscinetto	Bearing	Kugellager
	5043	Anello di tenuta	Oil seal	Simmering
	5044	Anello seeger	Circlip	Seegerring
	5046	Linguetta	Key	Paßfeder
	5047	Vite di fissaggio	Fixing screw	Befestigungsschraube
	5051	Anello O-ring	O-ring seal	O-ring
	5056	Tappo olio	Oil plug	Ölverschluß
	5057	Tappo olio	Oil plug	Ölverschluß
	5058	Vite di fissaggio	Fixing screw	Befestigungsschraube
	5061	Tappo olio	Oil plug	Ölverschluß
				Arbre d'entrée
				Capuchon
				Roulement
				Roulement
				Bague d'étanchéité
				Seeger
				Clavette
				Vis de fixation
				Bague O-ring
				Bouchon d'huile
				Bouchon d'huile
				Vis de fixation
				Bouchon d'huile

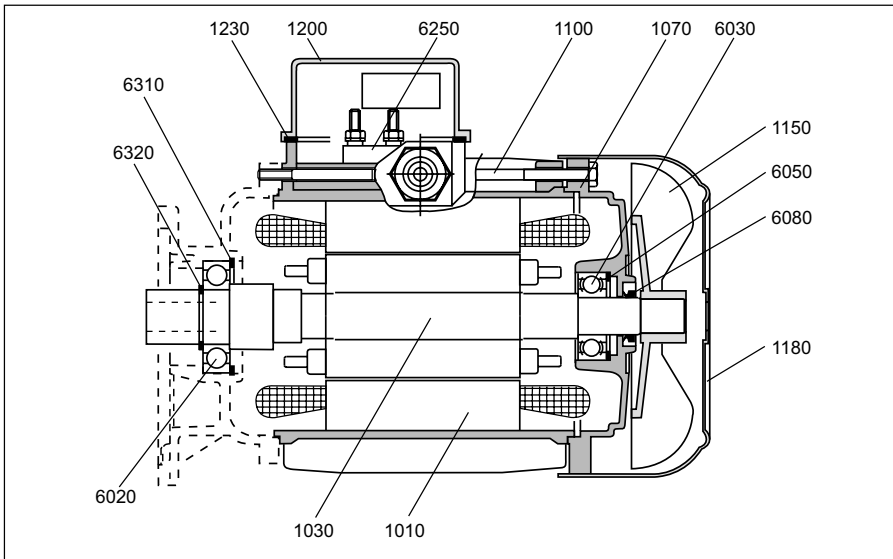

Motore M  
M motor  
M Motor  
Moteur M

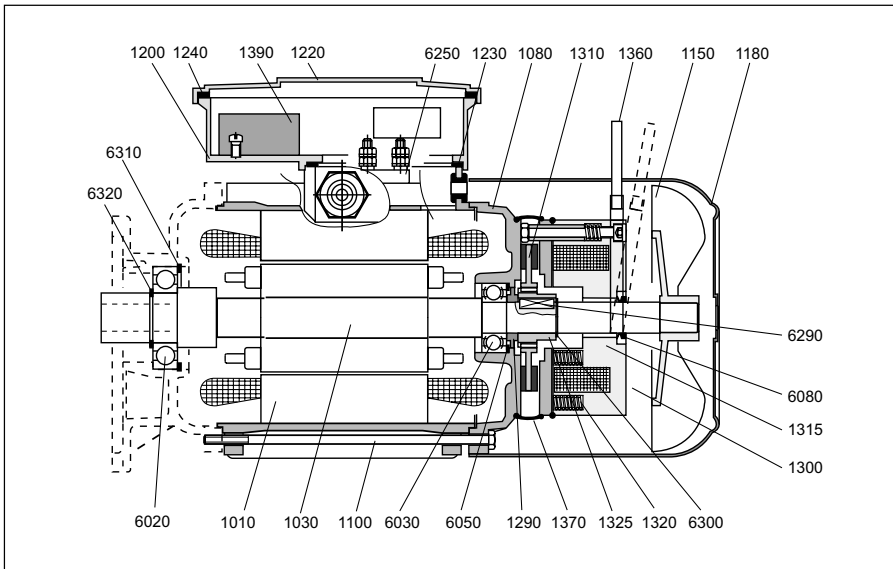

Motore M\_FD  
M\_FD motor  
M\_FD Motor  
Moteur M\_FD

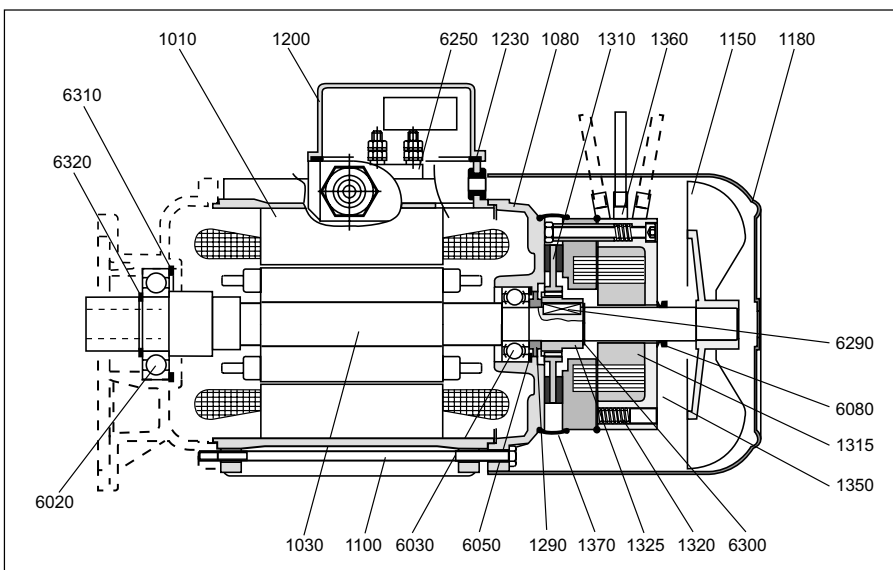

Motore M\_FA  
M\_FA motor  
M\_FA Motor  
Moteur M\_FA

<b>M</b>	ref.				
<b>M</b> <b>M_FD</b> <b>M_FA</b>	1010	Statore completo	<i>Stator</i>	Stator	<i>Stator</i>
	1030	Rotore completo	<i>Rotor</i>	Läufer	<i>Rotor</i>
	1100	Tiranti	<i>Tie-rods</i>	Zugbolzen	<i>Entretroises</i>
	1150	Ventola	<i>Fan</i>	Lüfterrad	<i>Ventilateur</i>
	1180	Copriventola	<i>Fan cowl</i>	Lüfterraddeckel	<i>Couvre - ventilateur</i>
	1200	Scatola coprimorsettiera	<i>Terminal box lid</i>	Klemmkastendeckel	<i>Boîte à bornes</i>
	1230	Guarnizione scat. coprimors.	<i>Terminal box seal</i>	Klemmkastendeckeldichtung	<i>Joint de la boîte à bornes</i>
	6020	Cuscinetto	<i>Bearing</i>	Kugellager	<i>Roulement</i>
	6030	Cuscinetto	<i>Bearing</i>	Kugellager	<i>Roulement</i>
	6050	Anello di compensazione	<i>Compensation ring</i>	Kompensationsring	<i>Bague de compensation</i>
	6080	Anello V-RING	<i>V-ring</i>	V-Ring	<i>Bague V-ring</i>
	6250	Morsettiera	<i>Terminal board</i>	Klemmkasten	<i>Boîte à bornes</i>
	6310	Anello seeger	<i>Circlip</i>	Seegerring	<i>Seeger</i>
	6320	Anello seeger	<i>Circlip</i>	Seegerring	<i>Seeger</i>
<b>M</b>	1070	Scudo NDE	<i>NDE shield</i>	Schild	<i>Bouclier</i>
<b>M_FD</b> <b>M_FA</b>	1080	Scudo per mot. autofrenante	<i>Shield for brake motor</i>	Schild für Bremsmotor	<i>Bouclier pour moteur frein</i>
	1290	Distanziale	<i>Spacer ring</i>	Distanzstück	<i>Entretoise</i>
	1360	Leva di sblocco	<i>Hand release lever kit</i>	Kit Handlüfterhebel	<i>Kit levier déblocage</i>
	1370	Protezione freno	<i>Brake seal kit</i>	Kit Bremsdichtungen	<i>Kit bagues frein</i>
	6290	Linguetta (mozzo freno)	<i>Key (brake hub)</i>	Paßfeder (Bremsenabe)	<i>Clavette (moyeu frein)</i>
	6300	Anello seeger	<i>Circlip</i>	Seegerring	<i>Seeger</i>
<b>M_FD</b>	1220	Coperchio scat.coprimorsett.	<i>Terminal box lid</i>	Klemmkastendeckel	<i>Couvercle boîte à bornes</i>
	1240	Guarniz. coperchio coprim.	<i>Terminal box seal</i>	Klemmkastendeckeldichtung	<i>Joint du couvercle de la boîte à bornes</i>
	1300	Freno tipo FD c.c.	<i>d.c. Brake type FD</i>	Bremstyp FD G.S.	<i>Frein type FD c.c.</i>
	1390	Raddrizzatore	<i>a.c./d.c. Rectifier</i>	Gleichrichter	<i>Redresseur</i>
<b>M_FA</b>	1350	Freno tipo FA c.a.	<i>a.c. Brake type FA</i>	Bremstyp FA D.S.	<i>Frein type FA c.a.</i>

## BN 63

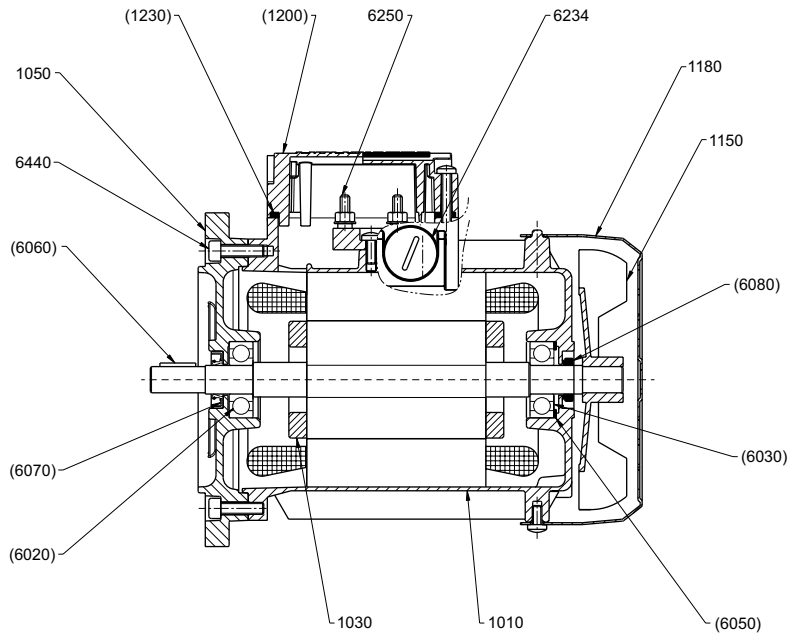

kit	ref.				
	1010	Statore completo	<i>Stator winding complete</i>	Stator	<i>Stator</i>
	1030	Rotore completo	<i>Rotor shaft</i>	Läufer komplett	<i>Rotor</i>
	1050	Flangia (IM B5/IM B14)	<i>Mounting flange (IM B5/IM B14)</i>	Flansch (IM B5/IM B14)	<i>Bride (IM B5/IM B14)</i>
	1150	Ventola	<i>Fan</i>	Lüfter	<i>Ventilateur</i>
	1180	Copriventola	<i>Fan cover</i>	Lüfterhaube	<i>Couvre ventilateur</i>
<b>KSM</b>	(1200)	Scatola coprimorsettiera	<i>Terminal box lid</i>	Klemmenkastendeckel	<i>Couvercle boîte a bornes</i>
	(1230)	Guarnizione scatola coprimorsettiera	<i>Terminal box gasket</i>	Klemmenkastendeckeldichtung	<i>Joint de la boîte a bornes</i>
	6234	Riduzione filettata M/Pg	<i>Metric/Pg adapter</i>	Reduzierstück M/Pg	<i>Reduction filet à pas Metrique/Pg</i>
	6250	Morsettiera	<i>Terminal board</i>	Klemmenplatte	<i>Boîte à bornes</i>
	6440	Vite serraggio flangia	<i>Bolt</i>	Schraube	<i>Vis</i>
<b>KSA</b>	(6020)	Cuscinetto	<i>Bearing</i>	Kugellager	<i>Roulement</i>
	(6030)	Cuscinetto	<i>Bearing</i>	Kugellager	<i>Roulement</i>
	(6050)	Anello di compensazione	<i>Compensation ring</i>	Federring	<i>Bague de compensation</i>
	(6060)	Linguetta	<i>Key</i>	Paßfeder	<i>Clavette</i>
	(6070)	Anello di tenuta	<i>Seal ring</i>	Dichtring	<i>Bague d'étanchéité</i>
	(6080)	Anello V-ring	<i>V-ring</i>	V-ring	<i>Bague V-ring</i>

(####) Disponibile SOLO in kit

(####) Only available as a complete kit

(####) Nur lieferbar als Kit

(####) Disponible seulement en kit

## BN 71...BN 160MR

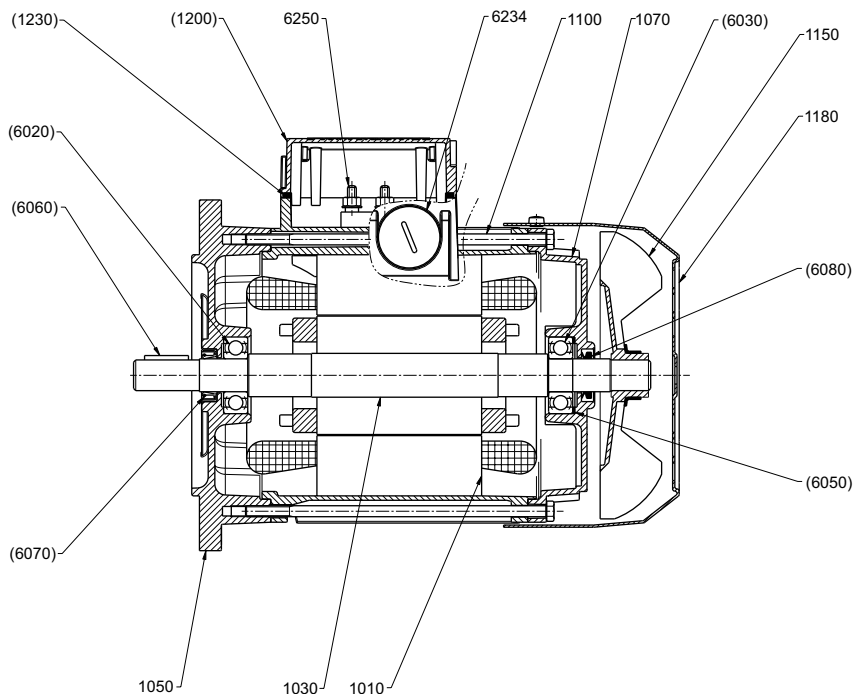

Kit	rif.				
<b>KSM</b>	1010	Statore completo	<i>Stator winding complete</i>	Stator	<i>Stator</i>
	1030	Rotore completo	<i>Rotor shaft</i>	Läufer komplett	<i>Rotor</i>
	1050	Flangia (B5/B14)	<i>Mounting flange (B5/B14)</i>	Flansch (B5/B14)	<i>Bride (B5/B14)</i>
	1070	Scudo NDE	<i>Rear shield</i>	Lagerschild Nichtantriebsseite	<i>Bouchier</i>
	1100	Tiranti	<i>Tie-rods</i>	Zuganker	<i>Entretoises</i>
	1150	Ventola	<i>Fan</i>	Lüfter	<i>Ventilateur</i>
	1180	Copriventola	<i>Fan cover</i>	Lüfterhaube	<i>Couvre ventilateur</i>
	(1200)	Scatola coprimorsettiera	<i>Terminal box lid</i>	Klemmenkastendeckel	<i>Couvercle boîte a bornes</i>
	(1230)	Guarnizione scatola coprimorsettiera	<i>Terminal box gasket</i>	Klemmenkastendeckeldichtung	<i>Joint de la boîte a bornes</i>
	<b>KSA</b>	6234	Riduzione filettata M/Pg	<i>Metric/Pg adapter</i>	Reduzierstück M/Pg
6250		Morsettiera	<i>Terminal board</i>	Klemmenplatte	<i>Boîte à bornes</i>
(6020)		Cuscinetto	<i>Bearing</i>	Kugellager	<i>Roulement</i>
(6030)		Cuscinetto	<i>Bearing</i>	Kugellager	<i>Roulement</i>
(6050)		Anello di compensazione	<i>Compensation ring</i>	Federring	<i>Bague de compensation</i>
(6060)		Linguetta	<i>Key</i>	Paßfeder	<i>Clavette</i>
(6070)		Anello di tenuta	<i>Seal ring</i>	Dichtring	<i>Bague d'étanchéité</i>
(6080)		Anello V-ring	<i>V-ring</i>	V-ring	<i>Bague V-ring</i>

(####) Disponibile SOLO in kit

(####) Only available as a complete kit

(####) Nür lieferbar als Kit

(####) Disponible seulement en kit

## BN 160M...BN 200

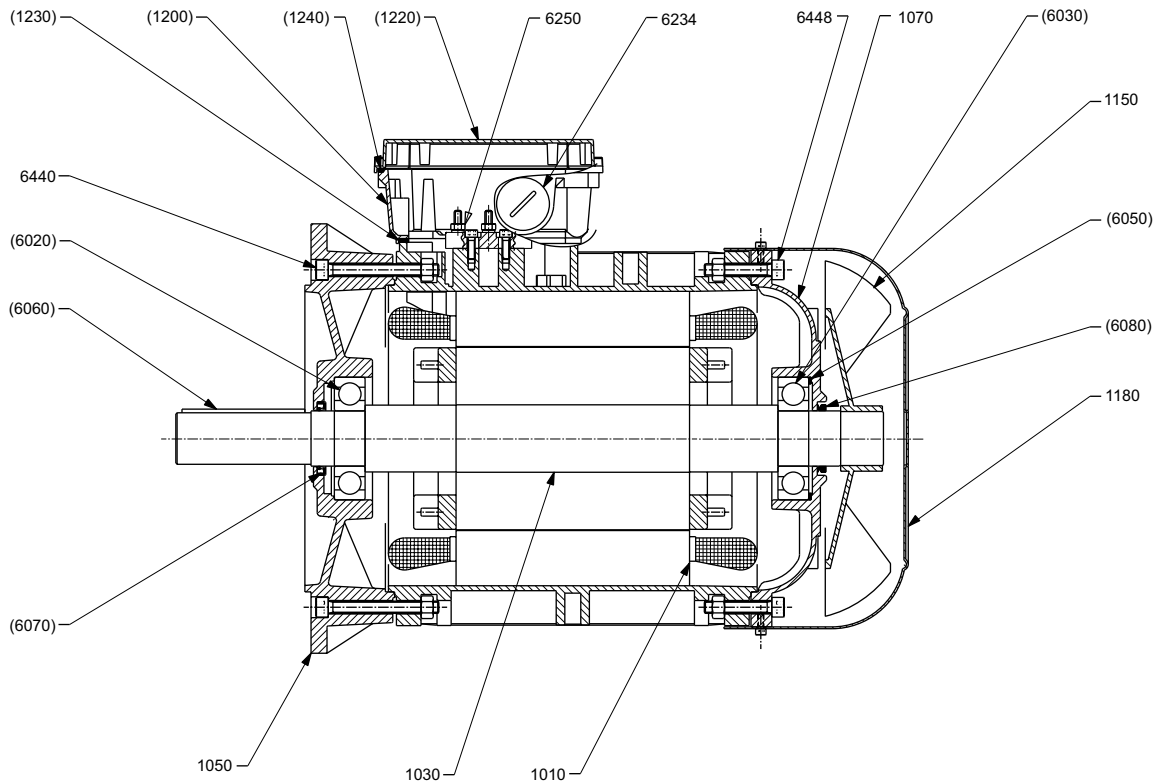

Kit	ref.				
	1010	Statore completo	<i>Stator winding complete</i>	Stator	<i>Stator</i>
	1030	Rotore completo	<i>Rotor shaft</i>	Läufer komplett	<i>Rotor</i>
	1050	Flangia (IM B5)	<i>Mounting flange (IM B5)</i>	Flansch (IM B5)	<i>Bride (IM B5)</i>
	1070	Scudo NDE	<i>Rear shield</i>	Lagerschild Nichtantriebsseite	<i>Bouchier</i>
	1150	Ventola	<i>Fan</i>	Lüfter	<i>Ventilateur</i>
	1180	Copriventola	<i>Fan cover</i>	Lüfterhaube	<i>Couvre ventilateur</i>
	<b>KSM</b>	(1200)	Scatola coprimorsettiera	<i>Terminal box</i>	Klemmenkasten
(1220)		Coperchio coprimorsettiera	<i>Terminal box lid</i>	Klemmenkastendeckel	<i>Couvercle boîte a bornes</i>
(1230)		Guarnizione scatola coprimorsettiera	<i>Terminal box gasket</i>	Klemmenkastendichtung	<i>Joint de la boîte a bornes</i>
(1240)		Guarnizione coperchio coprimors.	<i>Lid gasket</i>	Klemmenkastendeckeldichtung	<i>Joint couvercle boîte a bornes</i>
<b>KSA</b>	6234	Riduzione filettata M/Pg	<i>Metric/Pg adapter</i>	Reduzierstück M/Pg	<i>Reduction filet à pas Metrique/Pg</i>
	6250	Morsettiera	<i>Terminal board</i>	Klemmenplatte	<i>Boîte a bornes</i>
	6440	Viti flangia	<i>DE flange bolts</i>	Flanschschrauben	<i>Vis bride</i>
	6448	Viti scudo NDE	<i>NDE shield bolts</i>	Motorschildschrauben	<i>Vis bouclier NDE</i>
	(6020)	Cuscinetto	<i>Bearing</i>	Kugellager	<i>Roulement</i>
	(6030)	Cuscinetto	<i>Bearing</i>	Kugellager	<i>Roulement</i>
	(6050)	Anello di compensazione	<i>Compensation ring</i>	Federring	<i>Bague de compensation</i>
	(6060)	Linguetta	<i>Key</i>	Paßfeder	<i>Clavette</i>
(6070)	Anello di tenuta	<i>Seal ring</i>	Dichtring	<i>Bague d'étanchéité</i>	
(6080)	Anello V-ring	<i>V-ring</i>	V-ring	<i>Bague V-ring</i>	

(####) Disponibile SOLO in kit

(####) Only available as a complete kit

(####) Nür lieferbar als Kit

(####) Disponible seulement en kit

## BN 63\_FD

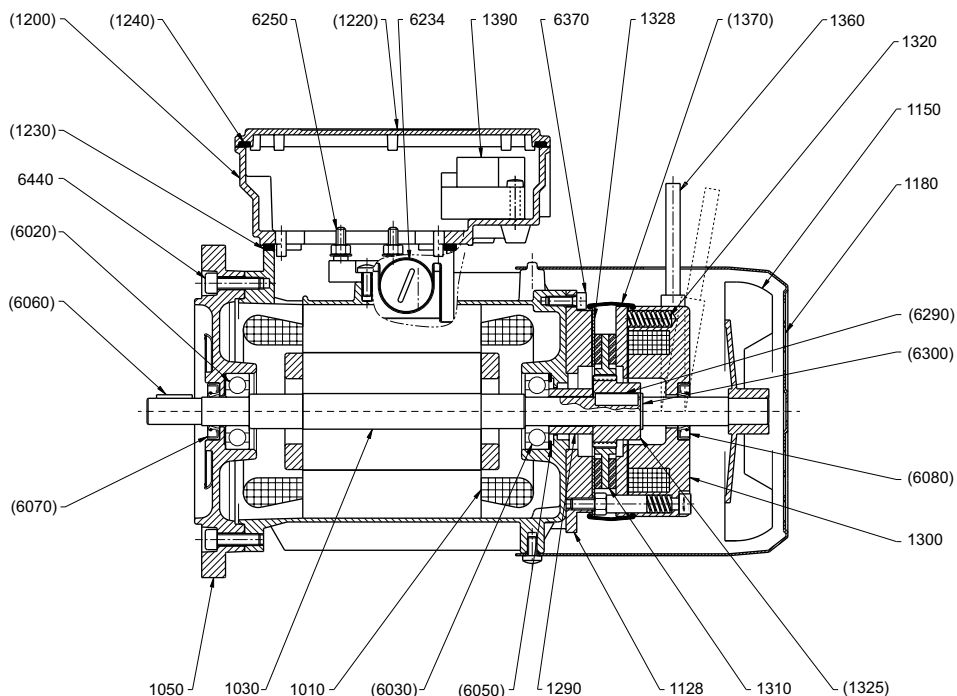

Kit	ref.				
	1010	Statore completo	<i>Stator winding complete</i>	Stator	<i>Stator</i>
	1030	Rotore completo	<i>Rotor shaft</i>	Läufer komplett	<i>Rotor</i>
	1050	Flangia (B5/B14)	<i>Mounting flange (B5/B14)</i>	Flansch (B5/B14)	<i>Bride (B5/B14)</i>
	1128	Anello attacco freno	<i>Brake holding plate</i>	Bremslagerschild	<i>Anneau attelage frein</i>
	1150	Ventola	<i>Fan</i>	Lüfter	<i>Ventilateur</i>
	1180	Copriventola	<i>Fan cover</i>	Lüfterhaube	<i>Couvre ventilateur</i>
<b>KSM</b>	(1200)	Scatola coprimorsettieria	<i>Terminal box</i>	Klemmenkasten	<i>Boîte a bornes</i>
	(1220)	Coperchio coprimorsettieria	<i>Terminal box lid</i>	Klemmenkastendeckel	<i>Couvercle boîte a bornes</i>
	(1230)	Guarnizione coprimorsettieria	<i>Terminal box gasket</i>	Klemmenkastendichtung	<i>Joint de la boîte a bornes</i>
	(1240)	Guarnizione coperchio	<i>Lid gasket</i>	Klemmenkastendeckeldichtung	<i>Joint couvercle de la boîte a bornes</i>
<b>KTF</b>	1290	Distanziale	<i>Spacer ring</i>	Distanzring	<i>Entretoise</i>
	1300	Freno in c.c. tipo FD	<i>d.c. brake type FD</i>	Gleichstrombremse Typ FD	<i>Frein c.c. type FD</i>
	1310	Disco freno	<i>Brake disc</i>	Bremsscheibe	<i>Disc frein</i>
	1320	Molle di pressione	<i>Brake springs</i>	Bremsfedern	<i>Ressorts frein</i>
	(1325)	Mozzo freno	<i>Brake hub</i>	Nabe	<i>Moyeu frein</i>
	(6290)	Linguetta mozzo freno	<i>Key (brake hub)</i>	Paßfeder (Nabe)	<i>Clavette (moyeu frein)</i>
<b>KPF</b>	(6300)	Anello elastico	<i>Circlip</i>	Seegerring	<i>Seeger</i>
	1328	Anello in acciaio inox (IP55)	<i>Stainless steel disc (IP55)</i>	Anlaufscheibe INOX (IP55)	<i>Bague en acier inox (IP55)</i>
	1360	Leva di sblocco	<i>Hand release lever</i>	Handlüfthebel	<i>Levier déblocage</i>
	(1370)	Guarnizione freno (IP55)	<i>Grommet (IP55)</i>	Gummiring (IP55)	<i>Bague frein (IP55)</i>
<b>KSA</b>	(6080)	Anello V-ring (IP55)	<i>V-ring (IP55)</i>	V-ring (IP55)	<i>Bague V-ring (IP55)</i>
	1390	Alimentatore ac/dc	<i>ac/dc rectifier</i>	Gleichrichter	<i>Redresseur c.a./c.c.</i>
	(6020)	Cuscinetto	<i>Bearing</i>	Kugellager	<i>Roulement</i>
	(6030)	Cuscinetto	<i>Bearing</i>	Kugellager	<i>Roulement</i>
	(6050)	Anello di compensazione	<i>Compensation ring</i>	Kompensationsring	<i>Bague de compensation</i>
	(6060)	Linguetta	<i>Key</i>	Paßfeder	<i>Clavette</i>
	(6070)	Anello di tenuta	<i>Seal ring</i>	Dichtring	<i>Bague d'étanchéité</i>
	6234	Riduzione filettata M/Pg	<i>Metric/Pg adapter</i>	Reduzierstück M/Pg	<i>Reduction filet à pas Metrique/Pg</i>
6250	Morsettieria	<i>Terminal board</i>	Klemmenplatte	<i>Boîte à bornes</i>	
6370	Viti fissaggio anello attacco freno	<i>Bolts</i>	Schraube	<i>Vis</i>	
6440	Viti fissaggio flangia	<i>Bolts</i>	Schraube	<i>Vis</i>	

(####) Disponibile SOLO in kit

(####) Only available as a complete kit

(####) Nür lieferbar als Kit

(####) Disponible seulement en kit